

MS Familie von bürstenlosen Servomotoren für Kleinspannungen

Datenblatt



- Polzahl: 6
- Feedback: Encoder (2048 Striche, TTL) mit Hallnachbildung (E), Resolver (R), Absolutgeber t.b.d. (A)
- Schutzklasse: IP64, optional IP65 / IP67 ohne (V) oder mit (W) Wellendichtring
- Elektrische Anschlüsse: gerade Flanschdose (Intercontec), optional drehbare Winkelstecker, (MS1: 0,3 m Kabel mit Stecker oder Einzellitzen)
- Thermischer Motorschutz: PTC, optional: Thermostarter 145°C, KTY oder NTC
- Welle ohne Passfeder, optional: Passfeder DIN 6885 (P)
- Optionen: Kabel (K), Sonderausführungen

Bezeichnung:

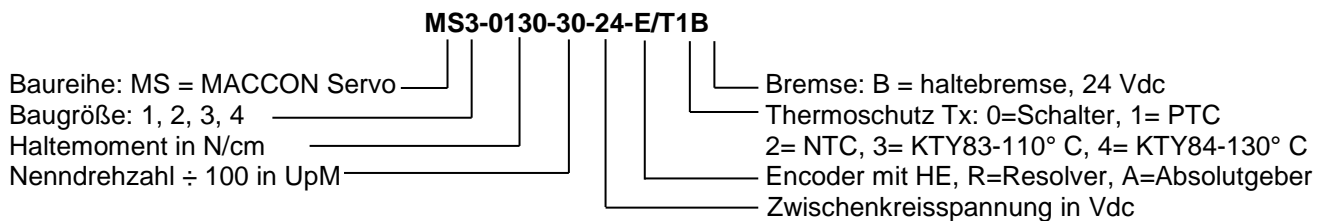

Abmessungen (mm):

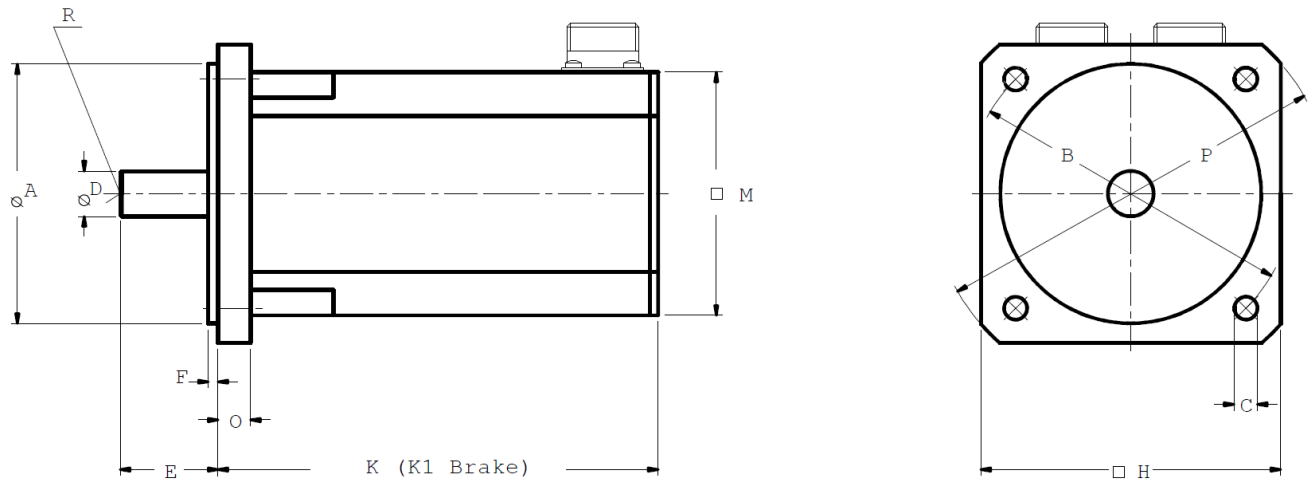

	A _{j6}	B	C	D _{k6}	E	F	H	K		K1	M	O	P	R
								Encoder	Resolver					
MS1-0010	25	32	4x M3x7	6h6	16	2	37	tbd	81	+30	37			--
MS1-0020	25	32	4x M3x7	6h6	16	2	37	tbd	96	+30	37			--
MS1-0030	25	32	4x M3x7	6h6	16	2	37	tbd	111	+30	37			--
MS2-0020	40	63	5,8	9	24	2,5	55	120,5	98	+33	50	7	74	--
MS2-0040	40	63	5,8	9	24	2,5	55	135,5	113	+33	50	7	74	--
MS2-0060	40	63	5,8	9	24	2,5	55	150,5	128	+33	50	7	74	--
MS2-0080	40	63	5,8	9	24	2,5	55	165,5	143	+33	50	7	74	--
MS3-0065	80	100	7	14	30	3	86	122	109	+33	74	11	115	M4x10
MS3-0130	80	100	7	14	30	3	86	140	127	+33	74	11	115	M4x10
MS3-0190	80	100	7	14	30	3	86	158	145	+33	74	11	115	M4x10
MS3-0250	80	100	7	14	30	3	86	176	163	+33	74	11	115	M4x10

Wicklungsdaten für den Betrieb bei 24 Vdc ZK- Spannung:

Motor- typ	Nennmoment	Nennstrom	Nenn- drehzahl	Spitzen- moment	Spitzenstrom	Spannungs- konstante	Drehmoment- konstante	Widerstand (Ph.-Ph.)	Induktivität (Ph.-Ph.)	Rotorträgheit	Gewicht o. Bremse
	M_n	I_n	n_n	M_{max}	I_{max}	K_E	K_T	R_{2ph}	L_{2ph}	J	m
	Nm	A _{eff.}	min ⁻¹	Nm	A _{eff.}	V _{dc} /1000	Nm/ A _{eff.}	Ω	mH	kgcm ²	kg
MS1-0010-40-24	0.10	3.8	4000	0.32	12.0	2.40	0.03	1.04	0.18	0.06	0.37
MS1-0010-60-24	0.09	4.3	6000	0.38	17.4	1.98	0.02	0.71	0.12	0.06	0.37
MS1-0020-30-24	0.20	4.6	3000	0.74	17.4	3.96	0.05	0.71	0.17	0.08	0.45
MS1-0020-40-24	0.20	6.0	4000	0.76	23.0	2.97	0.03	0.53	0.12	0.08	0.45
MS1-0020-60-24	0.18	6.9	6000	0.80	30.9	2.40	0.03	0.34	0.08	0.08	0.45
MS1-0030-40-24	0.29	8.1	4000	1.20	34.8	3.11	0.04	0.32	0.08	0.10	0.53
MS2-0020-30-24	0.19	5.4	3000	0.68	19.0	3.25	0.04	0.65	0.40	0.06	0.90
MS2-0040-30-24	0.38	7.0	3000	1.56	29.4	4.81	0.06	0.42	0.36	0.08	1.06
MS2-0060-30-24	0.57	9.7	3000	2.35	41.3	5.37	0.06	0.30	0.28	0.11	1.21
MS2-0080-30-24	0.76	14.6	3000	3.2	63.4	4.67	0.05	0.16	0.16	0.13	1.36
MS3-0065-30-24	0.60	12.1	3000	2.6	52.8	4.52	0.05	0,21	0.25	0.50	1.75

Wicklungsdaten für den Betrieb bei 48 Vdc ZK- Spannung:

Motor- typ	Nennmoment	Nennstrom	Nenn- drehzahl	Spitzen- moment	Spitzenstrom	Spannungs- konstante	Drehmoment- konstante	Widerstand (Ph.-Ph.)	Induktivität (Ph.-Ph.)	Rotorträgheit	Gewicht o. Bremse
	M_n	I_n	n_n	M_{max}	I_{max}	K_E	K_T	R_{2ph}	L_{2ph}	J	m
	Nm	A _{eff.}	min ⁻¹	Nm	A _{eff.}	V _{dc} /1000	Nm/ A _{eff.}	Ω	mH	kgcm ²	kg
MS1-0010-30-48	0.10	1.7	3000	0.29	4.8	5.37	0.06	5.17	0.86	0.06	0.37
MS1-0010-40-48	0.10	2.1	4000	0.36	7.4	4.38	0.05	3.34	0.59	0.06	0.37
MS1-0010-60-48	0.09	2.5	6000	0.40	11.1	3.39	0.04	2.03	0.34	0.06	0.37
MS1-0020-40-48	0.20	3.2	4000	0.8	12.9	5.66	0.07	1.92	0.44	0.08	0.45
MS1-0020-60-48	0.18	3.7	6000	0.8	16.5	4.53	0.05	1.18	0.27	0.08	0.45
MS1-0030-40-48	0.29	3.8	4000	1.20	16.2	6.79	0.08	1.43	0.40	0.10	0.53
MS2-0040-30-48	0.38	4.3	3000	1.6	18.6	7.92	0.09	1.12	0.95	0.08	1.06
MS2-0080-30-48	0.76	6.9	3000	3.2	29.9	9.90	0.12	0.63	0.65	0.13	1.36
MS3-0130-30-48	1.15	9.9	3000	5.2	45.2	10.61	0.12	0.32	0.54	0.65	2.25
MS3-0130-60-48	1.00	17.5	6000	5.2	90.4	5.23	0.06	0.08	0.14	0.65	2.25
MS3-0190-30-48	1.60	14.6	3000	7.6	70.6	9.90	0.12	0.15	0.30	0.92	2.70
MS3-0250-30-48	2.15	14.6	3000	10.0	69.5	13.3	0.15	0.18	0.40	1.40	3.20

Andere Wicklungen auf Anfrage.

Steckerbelegung:

Motor (8 polig, Size 1)		TTL-Encoder (17 polig)		Resolver (12 polig)	
1, 4, 3	U, V, W	11, 16	+5V, 0V	4, 8	S1 (sin+), S3 (sin -)
2	Erde	9, 10	A, /A	3, 7	S4 (cos+), S2 (cos -)
A, B	Bremse + / -	7, 8	B, /B	5, 9	R2, R1 (Speisung + /)
		3, 4	Z, /Z	2, 6	Thermoschutz
		14, 15	Thermoschutz		
		5/6, 1/2, 12/13	Halls (U /U, V /V, W /W)		