

GPM16

The Printed Motor Works GPM16 is a totally enclosed dc motor in an ultra slim pancake profile. This pancake motor can provide a cost effective servo capability either direct drive or combined with a timing pulley/gearbox.

Features & Benefits

- Ultra slim profile
- Minimum torque ripple
- Very low inertia
- High peak torques
- Zero cogging
- Ultra slow/creep capability
- Low inductance
- EMC compatible

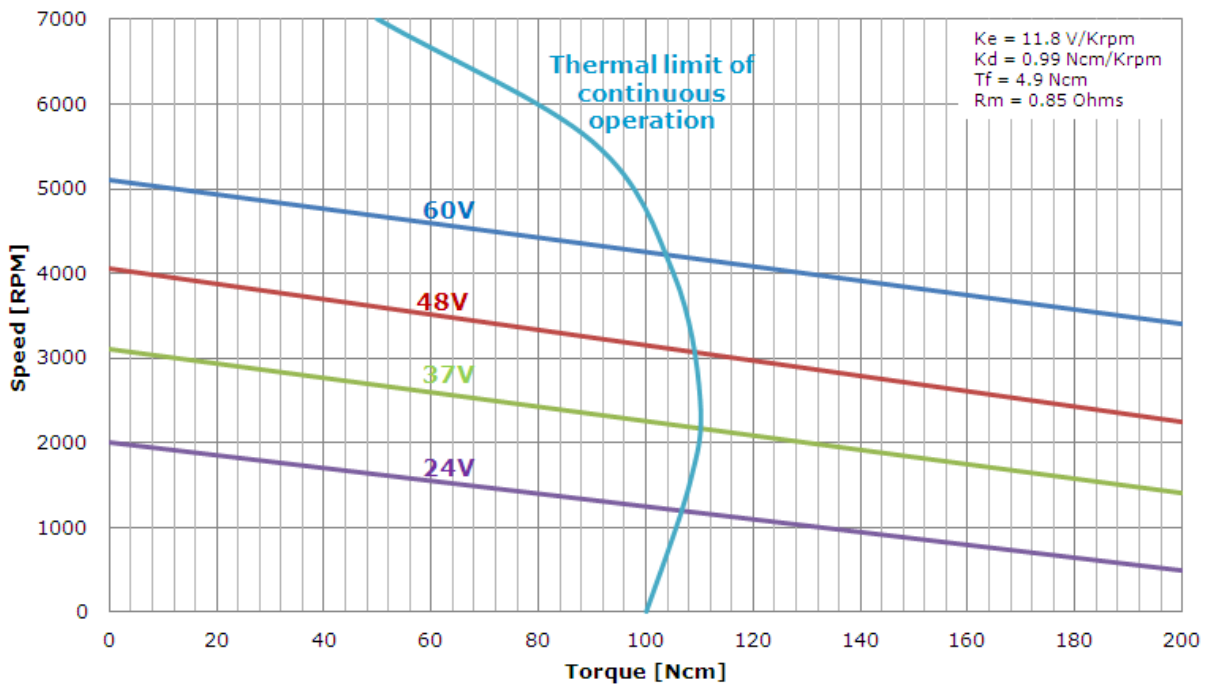
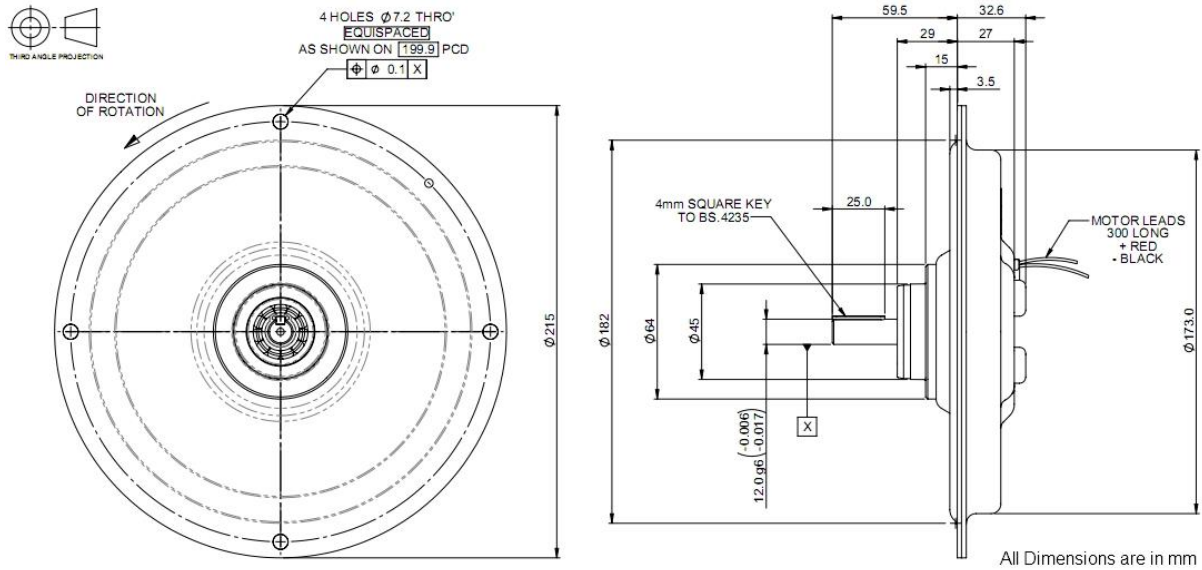
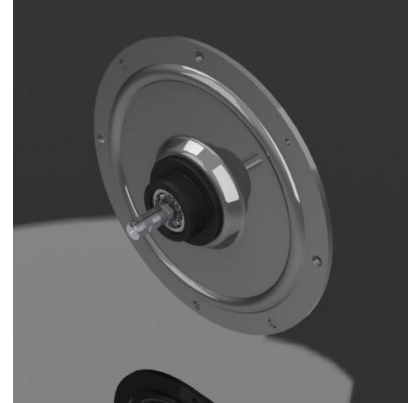

NOTE: The above voltages are examples, not a predefined maximum or minimum. Due to ongoing product improvements data is subject to change without notice.

Applications: Servo mechanisms, motion control, industrial robots, CNC machining, printing machinery, logistics solutions, medical mobility, medical scanners, flight simulators, marine autopilots and high ambient temperature ventilation.

Markets: Industrial automation, automotive, medical, life sciences, aerospace, printing, logistics, instrumentation, test and measurement, oil & gas and offshore marine.

Design Modifications

- Encoders
- Timing pulleys
- Long leads
- Tri-rated cable
- Open/kit option
- Customised shafts
- EMC suppression
- Connectors
- Rated for operation in 150°C ambient
- Mounting customisation

Performance Specifications	Symbol	Units	GPM16
Peak Torque	T _p	N-cm (oz-in)	960 (1359)
Rated Speed	N	RPM	3000
Rated Continuous Torque @ 25°C	T ₂₅	N-cm (oz-in)	110 (155.8)
Rated Power Output	P	Watts	300
Maximum Recommended Speed	N _{max}	RPM	6000
Continuous Stall Torque	T _s	N-cm (oz-in)	62.3 (88.22)
Cogging Torque	T _c	N-cm (oz-in)	0 (0)
Electrical Specifications			
Rated Terminal Voltage	E	Volts	43.3
Rated Continuous Current	I	Amps	9.3
Peak Current	I _p	Amps	86.2
Continuous Stall Current	I _s	Amps	6.0
Winding Specifications			
Terminal Resistance ± 10%	R _m	Ohms	0.85
Armature Resistance ± 10%	R _a	Ohms	0.74
Back EMF Constant ± 5%	K _e	V/kRPM	11.8
Torque Constant ± 5%	K _t	N-cm/Amp (oz-in/Amp)	11.2 (15.86)
Viscous Damping Constant	K _d	N-cm/KRPM (oz-in/KRPM)	0.99 (1.4)
Armature Inductance	L	µH	<0.03
Temperature Coefficient of KE	C	%/°C Rise	-0.19
Number of Commutation Bars	Z		165
Mechanical Specifications			
Moment of Inertia	J _m	Kg-cm ² (oz-in-sec ²)	6.284 (0.089)
Average Friction Torque	T _f	N-cm (oz-in)	4.9 (6.939)
Weight	W	kg (Ibs)	2.9 (6.393)
Diameter	D	mm (In)	215 (8.465)
Length	LG	mm (In)	32.6 (1.283)
Permitted Radial Load		Kg (Ibs)	6 (13.23)
Permitted Axial Load		Kg (Ibs)	6 (13.23)
Figure of Merit			
Mechanical Time Constant	T _m	ms	42.6
Electrical Time Constant	T _e	ms	<0.11
Thermal Specifications			
Thermal Resistance at Rated Speed	RAAR	°C/Watt	1.25
Thermal Resistance at Stall	RAAS	°C/Watt	1.9