

# XMGV SERIES

- ▶ Zero cogging, zero backlash, ironless linear positioning module
- ▶ Stroke from 15mm to 30mm
- ▶ Suitable for high speed and high acceleration application
- ▶ Smooth motion even at low speed (minimum velocity ripple)
- ▶ Uses cross roller guide for high stiffness

EN-24.3.1

# XMGV Series

## Introduction

The XMGV series linear modules combines cylindrical voice coil motors, precision crossed roller ways, and linear encoder feedback to realized high performance direct-drive motion in a compact package.

The product comes in four standard sizes: XMGV30, XMGV40, XMGV60, and XMGV90 to cater to a wide range of payloads. Two different precision grades (corresponding to different bearing and feedback options) provide additional flexibility to tailor the product to your application.

The built-in voice coil motor provides smooth, cogging-free actuation, while the crossed roller ways eliminate bearing reentry noise to enable accurate tracking of low velocities.

Continuous Force  $F_{cn} = 4.43\text{N} \sim 95.6\text{N}$









Peak Force  $F_{pk} = 28.20\text{N} \sim 340.3\text{N}$

## Features

- ▶ Direct drive, built-in cylindrical voice coil motor
- ▶ Stroke from 15mm to 30mm
- ▶ Repeatability up to  $\pm 0.5\mu\text{m}$
- ▶ Optional resolution of  $0.2\mu\text{m}$ ,  $0.05\mu\text{m}$ , SINCOS
- ▶ Excellent straightness and flatness, high rigidity, high dynamic performance

## Applications

Applications in various industries such as automation equipment which requires point-to-point high speed positioning, z-axis optical focusing, leveling mechanism, high speed pick and place, flying probe test, material fatigue tester and others.

Voice Coil Module Series	Voice Coil Motor Series	Continuous Force ( $F_{cn}$ )					Peak Force ( $F_{pk}$ )		Unit: N	Stroke (mm)	Repeatability ( $\mu\text{m}$ )	Page
		5	10	50	100	300	500					
 XMGV30	 AVM30	4.43					28.20			15	up to $\pm 0.5$	099
 XMGV40	 AVM40	10.5					61.7			20		099
 XMGV60	 AVM60	26.8					121.6			25		100
 XMGV90	 AVM90	95.6					340.3			30		100

Note:

★ Products can be customized to meet specific working environments or for high frequency reciprocating motion, please contact [cust-service@akribis-sys.com](mailto:cust-service@akribis-sys.com).

## XMGV30

Motor Specifications	Unit	Value	
Motor	-	AVM30-15	
Continuous Force (NC) @100°C <sup>1 2</sup>	N	4.43	
Peak Force <sup>2</sup>	N	28.2	
Force Constant ±10% <sup>2</sup>	N/A	7.03	
Back EMF Constant ±10% <sup>2</sup>	V/(m/s)	7.03	
Resistance @25°C ±10% <sup>3</sup>	Ω	10.24	
Inductance ±20% <sup>4</sup>	mH	2.82	
Continuous Current (NC) @100°C <sup>1</sup>	A	0.6	
Peak Current	A	4.0	
Max. Voltage	Vdc	60	
Mechanical Specifications	Unit	Value	
Precision Grade	-	P	N
Stroke <sup>5</sup>	mm	15	
Resolution	μm	SINCOS/0.05	0.2
Repeatability	μm	±0.5	±1.0
Horizontal Straightness	μm	±2.5	
Vertical Straightness	μm	±2.5	
Rated Payload <sup>6</sup>	kg	0.6	
No-load Moving Mass	kg	0.14	
No-load Total Mass	kg	0.51	
Max. Static Moment	Nm	0.8	

- <sup>1</sup> Measurement is taken at ambient temperature 25°C. Value depends on the thermal environment.
- <sup>2</sup> The values are at mid stroke.
- <sup>3</sup> Resistance is measured by DC current with standard 0.5m lead wire.
- <sup>4</sup> Inductance is measured by current frequency of 1 kHz.
- <sup>5</sup> Stroke refers to hardstop-to-hardstop mechanical stroke. The limit sensors are positioned 0.5mm from the hardstops.
- <sup>6</sup> The rated load is based on the load in which the acceleration of the mass is at least 1G. The contents of datasheet are subject to change without prior notice.

### Dimensional Drawing

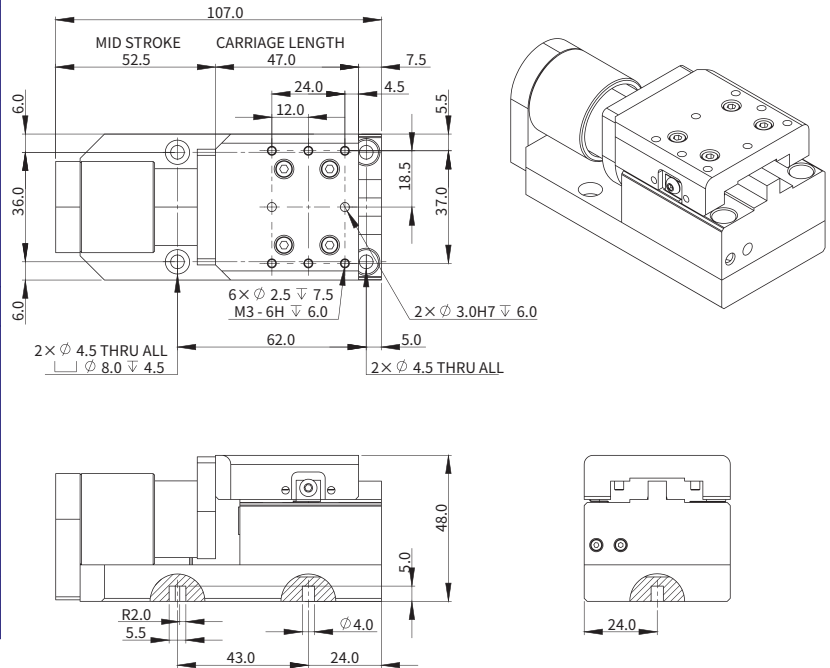

## XMGV40

Motor Specifications	Unit	Value	
Motor	-	AVM40-20	
Continuous Force (NC) @100°C <sup>1 2</sup>	N	10.5	
Peak Force <sup>2</sup>	N	61.7	
Force Constant ±10% <sup>2</sup>	N/A	13.6	
Back EMF Constant ±10% <sup>2</sup>	V/(m/s)	13.6	
Resistance @25°C ±10% <sup>3</sup>	Ω	11.5	
Inductance ±20% <sup>4</sup>	mH	5.2	
Continuous Current (NC) @100°C <sup>1</sup>	A	0.8	
Peak Current	A	4.5	
Max. Voltage	Vdc	60	
Mechanical Specifications	Unit	Value	
Precision Grade	-	P	N
Stroke <sup>5</sup>	mm	20	
Resolution	μm	SINCOS/0.05	0.2
Repeatability	μm	±0.5	±1.0
Horizontal Straightness	μm	±2.5	
Vertical Straightness	μm	±2.5	
Rated Payload <sup>6</sup>	kg	1.5	
No-load Moving Mass	kg	0.20	
No-load Total Mass	kg	0.80	
Max. Static Moment	Nm	1.4	

- <sup>1</sup> Measurement is taken at ambient temperature 25°C. Value depends on the thermal environment.
- <sup>2</sup> The values are at mid stroke.
- <sup>3</sup> Resistance is measured by DC current with standard 0.5m lead wire.
- <sup>4</sup> Inductance is measured by current frequency of 1 kHz.
- <sup>5</sup> Stroke refers to hardstop-to-hardstop mechanical stroke. The limit sensors are positioned 0.5mm from the hardstops.
- <sup>6</sup> The rated load is based on the load in which the acceleration of the mass is at least 1G. The contents of datasheet are subject to change without prior notice.

### Dimensional Drawing

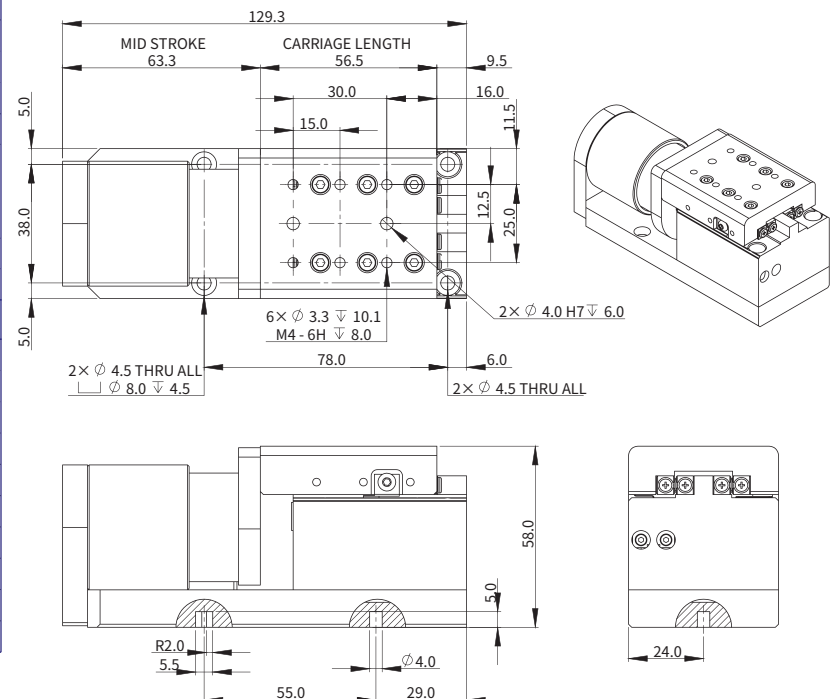

# XMGV Series

## XMGV60

Motor Specifications	Unit	Value	
Motor	-	AVM60-25	
Continuous Force (NC) @100°C <sup>1 2</sup>	N	26.8	
Peak Force <sup>2</sup>	N	121.6	
Force Constant ±10% <sup>2</sup>	N/A	17.3	
Back EMF Constant ±10% <sup>2</sup>	V/(m/s)	17.3	
Resistance @25°C ±10% <sup>3</sup>	Ω	5.35	
Inductance ±20% <sup>4</sup>	mH	3.82	
Continuous Current (NC) @100°C <sup>1</sup>	A	1.6	
Peak Current	A	7.0	
Max. Voltage	Vdc	60	
Mechanical Specifications	Unit	Value	
Precision Grade	-	P	N
Stroke <sup>5</sup>	mm	25	
Resolution	μm	SINCOS/0.05	0.2
Repeatability	μm	±0.5	±1.0
Horizontal Straightness	μm	±2.5	
Vertical Straightness	μm	±2.5	
Rated Payload <sup>6</sup>	kg	4.0	
No-load Moving Mass	kg	0.45	
No-load Total Mass	kg	1.90	
Max. Static Moment	Nm	3.4	

### Dimensional Drawing

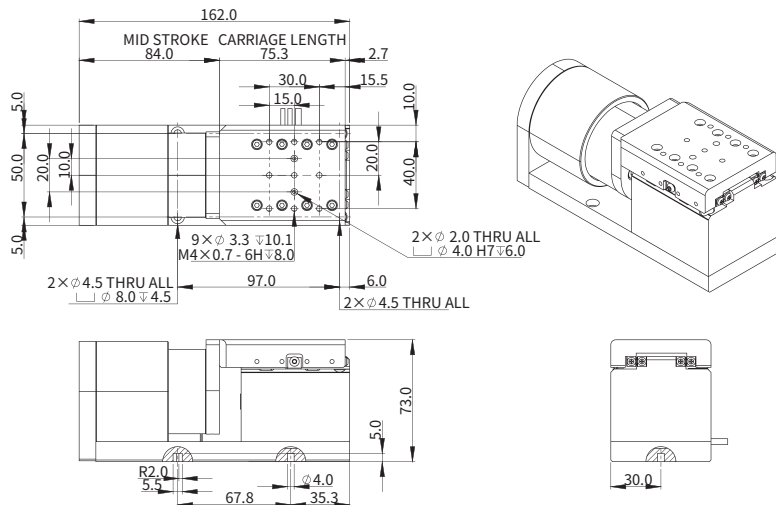

- <sup>1</sup> Measurement is taken at ambient temperature 25°C. Value depends on the thermal environment.
- <sup>2</sup> The values are at mid stroke.
- <sup>3</sup> Resistance is measured by DC current with standard 0.5m lead wire.
- <sup>4</sup> Inductance is measured by current frequency of 1 kHz.
- <sup>5</sup> Stroke refers to hardstop-to-hardstop mechanical stroke. The limit sensors are positioned 0.5mm from the hardstops.
- <sup>6</sup> The rated load is based on the load in which the acceleration of the mass is at least 1G. The contents of datasheet are subject to change without prior notice.

## XMGV90

Motor Specifications	Unit	Value	
Motor	-	AVM90-30	
Continuous Force (NC) @100°C <sup>1 2</sup>	N	95.6	
Peak Force <sup>2</sup>	N	340.3	
Force Constant ±10% <sup>2</sup>	N/A	23.9	
Back EMF Constant ±10% <sup>2</sup>	V/(m/s)	23.9	
Resistance @25°C ±10% <sup>3</sup>	Ω	2.73	
Inductance ±20% <sup>4</sup>	mH	3.80	
Continuous Current (NC) @100°C <sup>1</sup>	A	4.0	
Peak Current	A	14.0	
Max. Voltage	Vdc	120	
Mechanical Specifications	Unit	Value	
Precision Grade	-	P	N
Stroke <sup>5</sup>	mm	30	
Resolution	μm	SINCOS/0.05	0.2
Repeatability	μm	±0.5	±1.0
Horizontal Straightness	μm	±2.5	
Vertical Straightness	μm	±2.5	
Rated Payload <sup>6</sup>	kg	14.0	
No-load Moving Mass	kg	1.63	
No-load Total Mass	kg	5.31	
Max. Static Moment	Nm	16.0	

### Dimensional Drawing

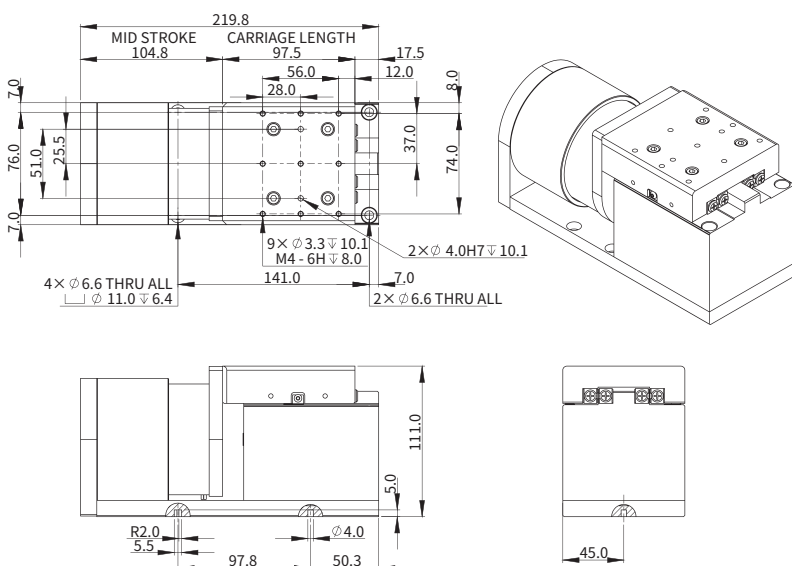

- <sup>1</sup> Measurement is taken at ambient temperature 25°C. Value depends on the thermal environment.
- <sup>2</sup> The values are at mid stroke.
- <sup>3</sup> Resistance is measured by DC current with standard 0.5m lead wire.
- <sup>4</sup> Inductance is measured by current frequency of 1 kHz.
- <sup>5</sup> Stroke refers to hardstop-to-hardstop mechanical stroke. The limit sensors are positioned 0.5mm from the hardstops.
- <sup>6</sup> The rated load is based on the load in which the acceleration of the mass is at least 1G. The contents of datasheet are subject to change without prior notice.

## Ordering Part Number (OPN)

**XMGV30-T15-A0G4-A1**

Model:

XMGV30  
XMGV40  
XMGV60  
XMGV90

Precision Grade:

Unmarked: Normal

Cover Type:

T: Standard (Black Anodized)

Stroke (Corresponding Models):

15: 15mm (XMGV30)  
20: 20mm (XMGV40)  
25: 25mm (XMGV60)  
30: 30mm (XMGV90)

Termination:

1: Motor: Flying Leads/Encoder: DSUB 15

Cable Length:

A: 0.5m

Scale Type:

4: Nickel, 14ppm/K

Encoder Type:

A0G: ABI-21 (0.2µm)

**XMGV30P-T15-R0A2-A1**

Model:

XMGV30  
XMGV40  
XMGV60  
XMGV90

Precision Grade:

P: Precision

Cover Type:

T: Standard (Black Anodized)

Stroke (Corresponding Models):

15: 15mm (XMGV30)  
20: 20mm (XMGV40)  
25: 25mm (XMGV60)  
30: 30mm (XMGV90)

Termination:

1: Motor: Flying Leads/Encoder: DSUB 15

Cable Length:

A: 0.5m

Scale Type:

2: Glass G8 Soda Lime, 8ppm/K

Encoder Type:

R0A: ATOM2, SINCOS (1Vpp)  
R0J: ATOM2, TTL (0.05µm)

Note:

★ Products can be customized to meet specific working environments or for high frequency reciprocating motion, please contact [cust-service@akribis-sys.com](mailto:cust-service@akribis-sys.com).

Wafer Stages | Gantry Stages | Stacked Stages | Air Bearing Modules | Picker Modules | Miniature Modules | Cross Roller Modules | Dual Guide Modules | Motion Control of Gantry Stages | Q&A | Sizing Guide | Introduction