

Frameless Motor

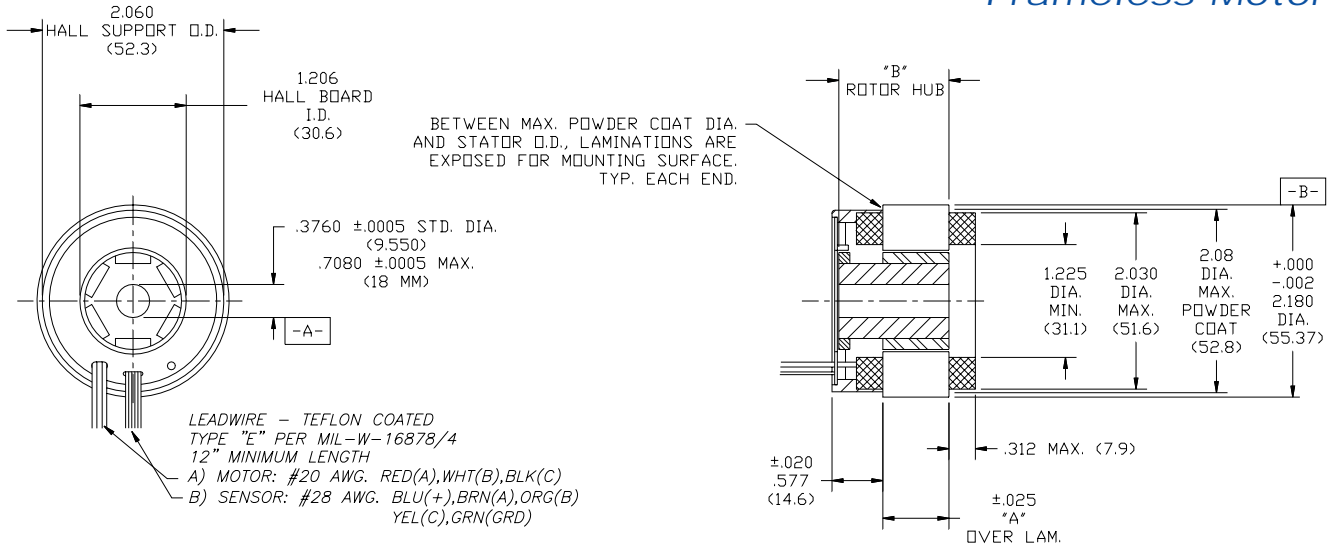

- MOTOR SUPPLIED AS TWO SEPARATE COMPONENTS, ROTOR ASSEMBLY AND STATOR ASSEMBLY.
- DIAMETERS "A" AND "B" TO BE CONCENTRIC WITHIN .002 WHEN MOUNTED
- STD. HUB LENGTH IS 1.250" LG. .750" HUBS ARE PROVIDED FOR CUSTOMER STACKING BEYOND 1.250".

MODEL NO.	"A" STATOR	"B" ROTOR
QB02300	.750 (19.05)	1.250 (31.75)
QB02301	1.500 (38.10)	2.000 (50.80)
QB02302	2.250 (57.15)	2.750 (69.85)
QB02303	3.000 (76.2)	3.500 (88.90)

Housed Motor

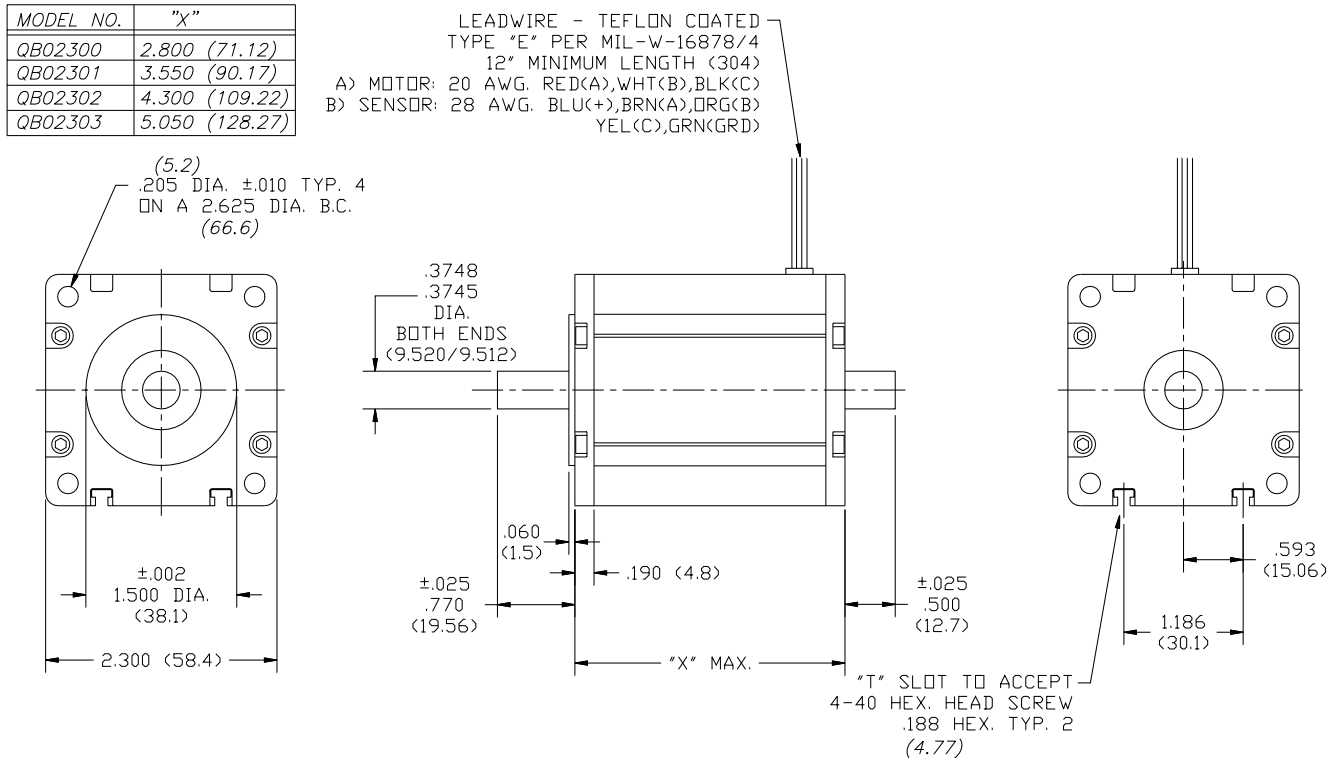

Electrical and Mechanical Data

Size Constants			QB02300			QB02301			QB02302			QB02303		
Max Cont. Stall Torque	T_C	Nm	0.36			0.68			0.98			1.28		
Max Rated Torque, 25%	T_R	Nm	3.94			7.9			11.8			15.6		
Motor Constant,	K_M	Nm/V	0.076			0.121			0.155			0.181		
Electrical Time Constant	T_E	msec	0.94			1.14			1.22			1.25		
Mechanical Time Constant	T_M	msec	1.30			1.03			0.94			0.92		
Thermal Resistance	TPR	°C/Watt	2.79			2.00			1.59			1.26		
Viscous Damping	F_V	Nm/rpm	2.5E-6			5.3E-6			7.9E-6			1.1E-5		
Max Cogging Torque	T_F	Nm	0.018			0.029			0.036			0.044		
Mechanical Constants														
Frameless Motor Inertia	J_M	Kg.m ²	7.6E-6			1.5E-5			2.3E-5			3.0E-5		
Frameless Motor Weight	Wt	Kg	0.25			0.48			0.71			0.95		
Housed Motor Inertia	J_M	Kg.m ²	7.9E-6			1.5E-5			2.3E-5			3.0E-5		
Housed Motor Weight	Wt	Kg	0.68			0.92			1.17			1.42		
Number of Poles	-	-	6			6			6			6		
Winding Constants														
			A	B	C	A	B	C	A	B	C	A	B	C
Design Voltage	V_P	Volts	24	40	130	24	40	130	24	40	130	24	40	130
Peak Torque	T_P	Nm	3.64	3.94	3.94	4.65	6.00	7.81	7.63	9.86	11.72	7.82	10.34	15.62
Peak Current	I_P	Amperes	95	81	32	61	62	40	100	104	56	77	81	70
Torque Constant, ±10%	K_T	Nm/A	0.038	0.048	0.121	0.076	0.096	0.192	0.076	0.095	0.208	0.101	0.126	0.222
No Load Speed	S_{NL}	RPM	5994	7888	10254	3014	3981	6470	3014	4035	5860	2269	3026	5588
		Rad/s	627	826	1073	315	416	677	315	422	624	237	316	585
BEMF Constant, ±10%	K_B	V/KRPM	4.0	5.0	12.6	7.9	10.0	20.0	7.9	9.9	21.8	10.5	13.2	23.2
		V/rad/s	0.038	0.048	0.121	0.076	0.096	0.192	0.076	0.095	0.208	0.101	0.126	0.222
Terminal Resistance, ±12%	R_M	Ohms	0.25	0.40	2.53	0.39	0.63	2.55	0.24	0.38	2.00	0.31	0.48	1.61
Terminal Inductance, ±30%	L_M	mH	0.23	0.38	2.37	0.45	0.72	2.88	0.29	0.46	2.22	0.39	0.60	1.87

Speed/Torque Curves

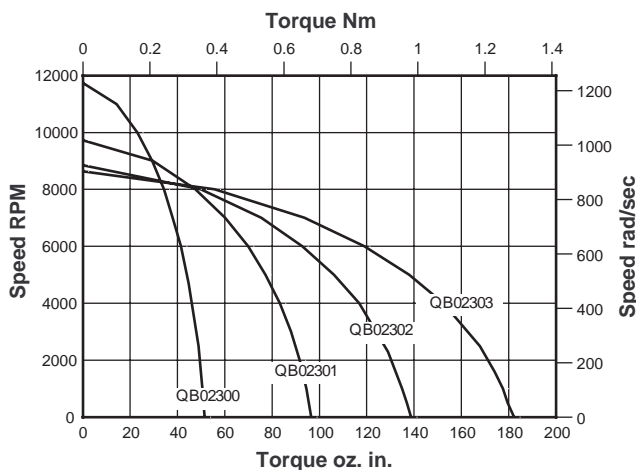

Continuous Duty Speed/Torque Curves for 100°C Temperature rise.

The continuous duty speed/torque curves provide a guide to the operational capability of the motors. Continuous operation at a loadpoint on or under the curve limits the temperature rise of the motor to 100°C. Although the duration of acceleration or deceleration periods should be checked, the RMS speed and torque combination should also lie on or under the continuous duty curve. The curves assume housed motors mounted to a nominal size of aluminum heatsink in a 25°C ambient environment and still air cooling. Higher ambient temperatures will generally decrease the continuous duty capability of a motor. With increased heatsink areas or improved cooling such as forced air or water, the continuous duty capability of the motor may be increased. However, for most applications, the practical maximum motor temperature is 150°C with Hall effect