



## FEATURES

- RoHS compliant
- Radial format
- Up to 1.8A I<sub>DC</sub>
- 10µH to 68mH
- Low DC resistance
- Miniature size
- PCB mounting
- MIL-I-23053/5 class III sleeving
- Fully tinned leads
- Supplied in packs of 20
- Compatible with RoHS soldering systems
- Backward compatible with Sn/Pb soldering systems
- Custom parts available

## DESCRIPTION

The 1700 Series is a general purpose range of inductors suitable for low to medium current applications. Their small footprint makes them ideal for high density applications where a chip inductor will not cope with the power requirement.

## SELECTION GUIDE

Order Code	Inductance, (1kHz)	DC Current <sup>1</sup>	DC Resistance	Q at f kHz		SRF
	±10%	Max.	Max.	Nom.		Nom.
	µH	A	Ω	Q	f	MHz
17103C	10.0	1.80	0.05	40	1000	21.2
17153C	15.0	1.50	0.06	30	500	19.4
17223C	22.0	1.20	0.08	30	500	17.0
17333C	33.0	1.00	0.13	25	500	11.4
17473C	47.0	0.86	0.20	25	500	10.9
17683C	68.0	0.85	0.26	70	100	10.6
17104C	100.0	0.74	0.35	65	100	8.9
17154C	150.0	0.58	0.49	80	100	6.2
17224C	220.0	0.48	0.75	90	100	5.4
17334C	330.0	0.42	1.10	95	100	4.5
17474C	470.0	0.34	1.50	100	100	3.2
17684C	680.0	0.28	2.40	105	100	3.0
17105C	1.0mH	0.19	3.30	120	100	2.5
17155C	1.5mH	0.15	5.90	130	100	2.1
17225C	2.2mH	0.12	7.80	130	50	1.9
17335C	3.3mH	0.11	9.1	125	150	1.2
17475C	4.7mH	0.09	12.0	130	150	0.95
17685C	6.8mH	0.08	20.0	135	150	0.85
17106C	10.0mH	0.07	34.0	140	150	0.62
17156C	15.0mH	0.06	45.0	145	150	0.51
17226C	22.0mH	0.05	75.0	100	50	0.34
17336C	33.0mH	0.04	100.0	90	50	0.28
17476C	47.0mH	0.03	140.0	80	50	0.25
17686C	68.0mH	0.02	220.0	70	50	0.20

## TYPICAL CORE/WIRE CHARACTERISTICS

Inductance Temperature Coefficient	Resistance Temperature Coefficient	Curie Temperature (T <sub>c</sub> )	Saturation Flux (B <sub>SAT</sub> )
350ppm	3900ppm	190°C	325mT

## ABSOLUTE MAXIMUM RATINGS

Operating free air temperature range	0°C to 70°C
Storage temperature range	-40°C to 125°C

## SOLDERING INFORMATION<sup>2</sup>

Peak wave solder temperature	300°C for 10 seconds
Pin finish	Bright tin

All specifications typical at T<sub>A</sub>=25°C

- 1 Maximum DC current occurs when either the inductance falls to 90% of its nominal value or when its temperature rise reaches 30°C, whichever is sooner.
- 2 For further information, please visit [www.murata-ps.com/rohs](http://www.murata-ps.com/rohs)



**PACKAGE SPECIFICATIONS**

**MECHANICAL DIMENSIONS**

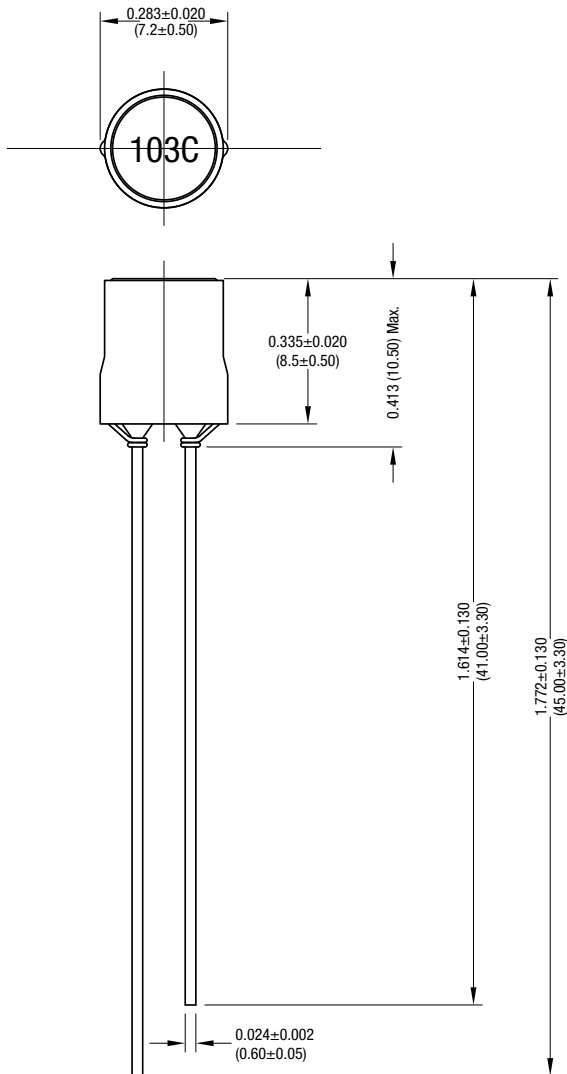

All dimensions in inches (mm). Package weight 1.3g Typ.

**RECOMMENDED FOOTPRINT DETAILS**

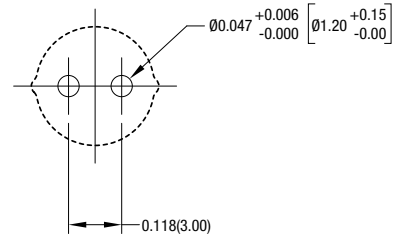

All dimensions in inches (mm)