

FEEDBACK VERSIONS

- Analog Sin/Cos
- Quad A/B digital
- Resolver

CONTROL MODES

- Indexer, Point-to-Point, PVT
- Camming, Gearing, Position, Velocity, Torque

COMMAND INTERFACE

- CANopen
- ASCII and discrete I/O
- Stepper commands
- ± 10 Vdc position/velocity/torque command
- PWM velocity/torque command
- Master encoder (Gearing/Camming)
- Digital inputs for indexer control

COMMUNICATIONS

- CANopen
- RS232

FEEDBACK

- Digital Quad A/B encoder
- Analog sin/cos encoder (-S versions)
- Resolver (-R versions)
- Secondary encoder / emulated encoder out
- Digital Halls

I/O - DIGITAL

- 14 inputs, 4 outputs

REGEN

- Internal

DIMENSIONS: MM [IN]

- 126 x 89 x 53 [5.0 x 3.5 x 2.1]

CANopen®



Model	Vac	Ic	Ip
XSJ-230-02	100-240	1	2
XSJ-230-06	100-240	3	6
XSJ-230-10	100-240	5	10

* Add "-S" to part number for Sin/Cos version
Add "-R" to part number for Resolver version

DESCRIPTION

Xenus Micro is a compact, AC powered servo drive for position, velocity, and torque control of AC brushless and DC brush motors. It operates on a distributed control network, as a stand-alone indexing drive, or with external motion controllers.

Feedback options now include brushless resolvers in addition to digital quad A/B and analog sin/cos incremental encoders. The multi-mode encoder port operates as an input or output for the feedback signals. As an input, a secondary digital quad A/B encoder is used for dual-loop position control. Resolver and sin/cos signals are interpolated internally with programmable resolution and appear as digital quad A/B signals when the port functions as an output. Or, the digital quad A/B signals are simply buffered and made available to the system controller, eliminating cumbersome Y-cabling to share a single encoder with drive and control system.

Indexing mode simplifies operation with PLC's that use outputs to select and launch indexes and inputs to read back drive status. A single serial port on the PLC can send ASCII data to multiple drives to change motion profiles as machine requirements change.

CAN bus operation supports Profile Position, Profile Velocity, Profile Torque, Interpolated Position, and Homing. Up to 127 *Xenus Micro* drives can operate on a single CAN bus and groups of drives can be linked via the CAN so that they execute motion profiles together. Operation in torque (current), velocity, and position modes with external motion controllers is supported. Input command signals are ± 10 Vdc (torque, velocity, position), PWM/Polarity (torque, velocity), or Step/Direction (position).

GENERAL SPECIFICATIONS

Test conditions: Load = Wye connected load: 2 mH + 2 Ω line-line. Ambient temperature = 25°C, +HV = HV_{max}

MODEL	XSJ-230-02	XSJ-230-06	XSJ-230-10
-------	------------	------------	------------

OUTPUT POWER

Peak Current	2 (1.4)	6 (4.2)	10 (7.1)	Adc (Arms, sinusoidal), ±5%
Peak time	1	1	1	Sec
Continuous current	1 (0.7)	3 (2.1)	5 (3.5)	Adc (Arms, sinusoidal), ±5%

INPUT POWER

HV _{min} ~ HV _{max} +24 Vdc	85 to 264 Vac +20 to +32 Vdc @ 500 mAdc maximum	1 Ø, 50~60 Hz Logic & control power, required for operation
--	--	--

PWM OUTPUTS

Type	3-phase MOSFET inverter, 15 kHz center-weighted PWM, space-vector modulation
PWM ripple frequency	30 kHz

REGENERATION

Type	Internal MOSFET dissipator
Power dissipation	80 W peak, 40 W continuous
Cut-In Voltage	+HV > 390 Vdc
Drop-Out Voltage	+HV < 380 Vdc
Tolerance	±2 Vdc
Hysteresis	10 ±0.5 Vdc

Regen output is on, regen dissipator is dissipating energy
Regen output is off, regen dissipator not dissipating energy
For either Cut-In or Drop-Out voltage
Differential between Cut-In & Drop-Out voltage

DIGITAL CONTROL

Digital Control Loops	Current, velocity, position. 100% digital loop control Dual loop position control using secondary encoder input
Sampling rate (time)	Current loop: 15 kHz (66.7 us) Velocity, position loops: 3 kHz (333 us)
Commutation	Sinusoidal field-oriented control or trapezoidal for brushless motors
Bandwidth	Current loop: 2.5 kHz typical, bandwidth will vary with tuning & load inductance
HV Compensation	Changes in bus voltage do not affect bandwidth
Minimum load inductance	200 µH line-line

COMMAND INPUTS

CAN	CANopen: Profile Position, Interpolated Position, Profile Velocity, Profile Torque, Homing
ASCII	Single RS-232 connection passes messages to multiple drives via CAN link drive-drive
Digital position reference	Step/Direction or CW/CCW Stepper commands (1.5 MHz maximum rate) 20 Mcount/sec after quadrature (5 Mline/sec)
Digital torque & velocity	Quad A/B Encoder PWM/Polarity PWM/50% PWM frequency range PWM minimum pulse width
Analog torque, velocity, position	±10 Vdc, 5 kΩ differential input impedance, 12-bit resolution
Indexing	Index address, index-start, priority-index start
Camming	Inputs for master encoder, cam start, cam table address

DIGITAL INPUTS

Number	14: 12 programmable, 1 input dedicated to drive Enable function, 1 for motor temperature switch
Type	8 General-purpose (GP), 3 high-speed single-ended (HS), 2 high-speed differential (HSD), 1 motemp (GP)
GP, HS	74HC14 Schmitt trigger operating from 5.0 Vdc with RC filter on input, 10 kΩ to +5 Vdc or ground (programmable), Vin-LO < 1.35 Vdc, Vin-HI > 3.65 Vdc +10 Vdc max for HS inputs, +24 Vdc max for GP inputs
HSD	1.5 MHz maximum pulse frequency for HS inputs when driven by active (not open-collector) sources Differential, 121 Ω line-line, 100 ns RC filters to RS-422/RS-485 line receivers, +10 Vdc max
Pull-up, pull-down control	5 MHz maximum pulse frequency when driven by differential line-drivers GP & HS inputs are divided into three groups with selectable connection of input pull-up/down resistor to +5 Vdc or ground for each group: [IN1,2,3,4], [IN5,6,7,8], [IN9,10,11]

DIGITAL OUTPUTS

Number	4
[OUT1], [OUT2], [OUT3]	Current-sinking MOSFET with 1 kΩ pull-up to +5 Vdc through diode
Ratings	250 mAdc max, +30 Vdc max External flyback diode required if driving inductive loads
Brake [OUT4]	Opto-isolated, current-sinking with flyback diode to +24 Vdc, 1 Adc max

RS-232 PORT

Mode	Full-duplex, DTE serial communication port for drive setup and control; 9,600 to 115,200 baud, 8 data bits, no parity, 1 stop-bit
Signals	RxD, TxD, Gnd
Protocol	Binary or ASCII formats
Multi-Drop	ASCII communications to multiple Copley drives via a single RS-232 port: RS-232 to first Drive_0, then daisy-chain to Drive_1~Drive_N via CAN

CAN PORT

Format	CAN V2.0b physical layer for high-speed connections compliant
Data	CANopen Device Profile DSP-402
Signals	CANH, CANL, Gnd
Isolation	CAN interface circuit and +5 Vdc supply are optically isolated from drive circuits
Address selection	Selectable by logic inputs or programmable in flash memory

MOTOR CONNECTIONS

Power	U-V-W phases for brushless, U-V for brush motors
Commutation	Digital Halls, or sin/cos feedback from ServoTube motors
Feedback	Digital quadrature A/B/(X) encoders; differential inputs (Standard) Analog sin/cos encoders, 1 Vpeak-peak, differential inputs with 121 Ω terminating resistor (-S option) Resolver, brushless, single-speed, 1:1 to 2:1 programmable transformation ratio (-R option) <i>See page 4 for details on encoders and resolvers</i>
Brake	Digital output, isolated, 1 Adc, +30 Vdc max, programmable, with flyback diode to +24 Vdc
Overtemp sensor	Digital input, non-isolated, 4.99 kΩ pull-up to +5 Vdc, programmable

MULTI-MODE ENCODER PORT

As Secondary Encoder Input	Digital quadrature encoder (A, /A, B, /B, X, /X), 20 M counts/sec, post-quadrature (5 M lines/sec)
As Emulated Encoder Output	Quadrature encoder emulation with programmable resolution to 4096 lines (65,536 counts) per rev from analog sin/cos encoders. 18 M counts/sec, post-quadrature (4.5 M lines/sec)
As Buffered Encoder Output	Buffered signals from digital quad A/B/X primary encoder. 20 M counts/sec, post-quadrature (5 M lines/sec) A, /A, B, /B, X, /X, signals from 26LS31 differential line driver

LED INDICATORS

Drive Status	Bicolor LED, drive status indicated by color, and blinking or non-blinking condition
CAN Status	Bicolor LED, status of CAN bus indicated by color and blink codes to CAN Indicator Specification 303-3

PROTECTIONS

HV Overvoltage	+HV > 400 Vdc	Drive PWM outputs disabled
HV Undervoltage	+HV < 60 Vdc	Drive PWM outputs disabled
Drive over temperature	Heatplate > 70 °C ±3 °C	Drive PWM outputs disabled
Short circuits	Output to output, output to ground, internal PWM bridge faults	
I2T Current limiting	Programmable: Current foldback to continuous limit when I2T threshold is exceeded	
Motor over temperature	Drive PWM outputs disabled when [IN14] changes state (programmable)	
Feedback power loss	Fault occurs if feedback +5 Vdc output is < 85% of nominal value	

MECHANICAL & ENVIRONMENTAL

Size	126 x 89 x 53 [5.0 x 3.5 x 2.1] mm [in]
Weight	0.67 lb (0.30 kg)
Ambient Temperature Range	0 to +45 °C operating, -40 to +85 °C storage
Humidity	0% to 95%, non-condensing
Vibration	2 g peak, 10~500 Hz (sine), IEC60068-2-6
Shock	10 g, 10 ms, half-sine pulse, IEC60068-2-27
Contaminants	Pollution degree 2
Environment	IEC68-2: 1990
Cooling	Heat sink and/or forced air cooling required for continuous power output

AGENCY STANDARDS CONFORMANCE

EN 55011 : 1998	CISPR 11 (1997) Edition 2/Amendment 2: Limits and Methods of Measurement of Radio Disturbance Characteristics of Industrial, Scientific, and Medical (ISM) Radio Frequency Equipment
EN 61000-6-1 : 2001	Electromagnetic Compatibility Generic Immunity Requirements
<i>Following the provisions of EC Directive 89/336/EEC:</i>	
EN 61010-1 2 nd Ed.: 2004	Safety Requirements for Electrical Equipment for Measurement, Control, and Laboratory use
<i>Following the provisions of EC Directive 2006/95/EC</i>	
UL 508C 3 rd Ed.: 2002	UL Standard for Safety for Power Conversion Equipment

FEEDBACK SPECIFICATIONS

ENCODERS

DIGITAL ENCODER

Type	Quadrature, differential line driver outputs
Signals	A, /A, B, /B, (X, /X, index signals optional)
Frequency	5 MHz line frequency, 20 MHz quadrature count frequency

ANALOG ENCODER (-S VERSIONS)

Type	Sin/cos, differential line driver outputs, 1.0 V _{peak-peak} differential centered about 2.5 V _{dc} typical. Common-mode voltage 0.25 to 3.75 V _{dc}
Signals	Sin(+), sin(-), cos(+), cos(-)
Frequency	230 kHz maximum line (cycle) frequency
Interpolation	10 bits/cycle (1024 counts/cycle)

DIGITAL HALLS

Type	Digital, single-ended, 120° electrical phase difference
Signals	U, V, W
Frequency	Consult factory for speeds >10,000 RPM

ENCODER POWER SUPPLY

Power Supply	+5 V _{dc} @ 400 mA to power encoders & Halls
Protection	Current-limited to 750 mA @ 1 V _{dc} if overloaded Encoder power developed from +24 V _{dc} so position information is not lost when AC mains power is removed

RESOLVER (-R VERSIONS)

RESOLVER

Type	Brushless, single-speed, 1:1 to 2:1 programmable transformation ratio
Resolution	14 bits (equivalent to a 4096 line quadrature encoder)
Reference frequency	7.5 kHz
Reference voltage	2.8 V _{rms} , auto-adjustable by the drive to maximize feedback
Reference maximum current	100 mA
Maximum RPM	10,000+

ENCODER EMULATION

Resolution	Programmable to 16,384 counts/rev (4096 line encoder equivalent)
Buffered encoder outputs	26C31 differential line driver

DIMENSIONS

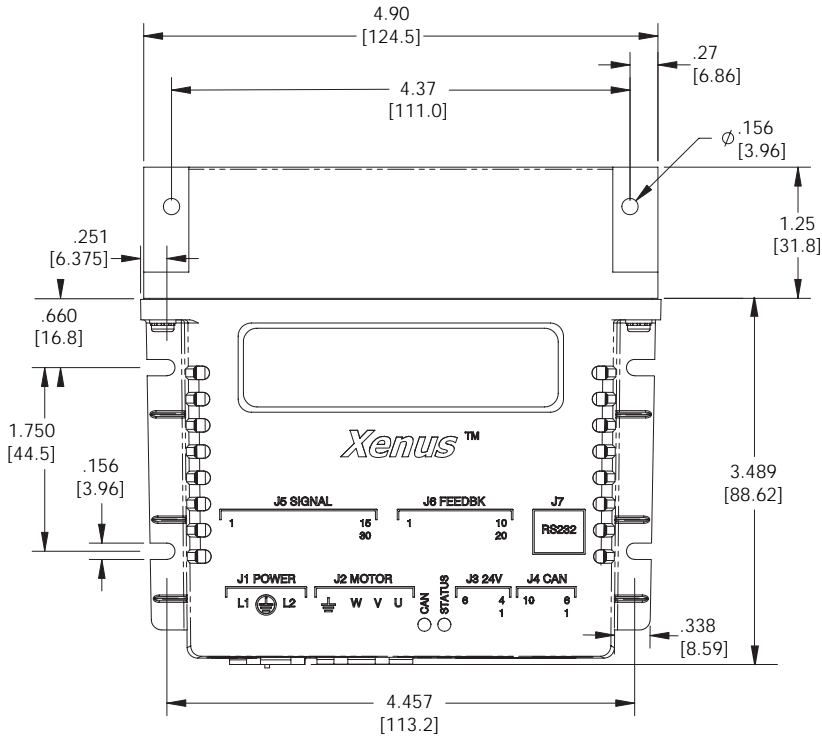

Notes

1. Dimensions shown in inches [mm].
2. Use external tooth lockwashers between mounting screw head and drive chassis for safety and CE compliance. Recommended screws are #6-32 (M3.5) torqued to 8~10 lb-in (0.79~1.02 N·m).

Weights:

Drive: 0.67 lb (0.30 kg)
Heatsink: 0.56 lb (0.25 kg)

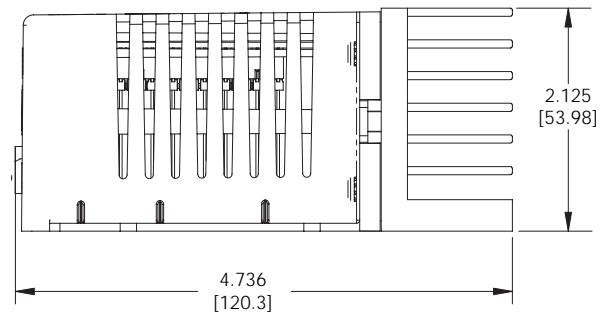
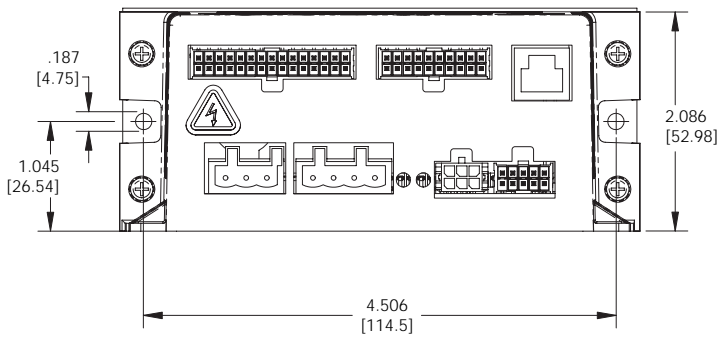

COMMUNICATIONS

CME 2 SOFTWARE

Drive setup is fast and easy using *CME 2* software. All of the operations needed to configure the drive are accessible through this powerful and intuitive program. Auto-phasing of brushless motor Hall sensors and phase wires eliminates “wire and try”. Connections are made once and *CME 2* does the rest thereafter. Encoder wire swapping to establish the direction of positive motion is eliminated.

Motor data can be saved as .ccm files. Drive data is saved as .ccx files that contain all drive settings plus motor data. This eases system management as files can be cross-referenced to drives. Once a drive configuration has been completed systems can be replicated easily with the same setup and performance.

When operating as a stand-alone drive that takes command inputs from an external controller, *CME 2* is used for configuration. When operated as a CAN node, *CME 2* is used for programming before and after installation in a CAN network. *Xenus Micro* can also be controlled via *CME 2* while it is in place as a CAN node. During this process, drive operation as a CAN node is suspended. When adjustments are complete, *CME 2* relinquishes control of the drive and returns it to the CAN node state.

RS-232

Xenus Micro is DTE device configured via a three-wire, full-duplex RS-232 port operating from 9,600 to 115,200 Baud, with 8 data-bits, no parity, and one stop-bit. The RS-232 specification makes no allowance for more than two devices on a serial link. But, multiple *Xenus Micro* drives can communicate over a single RS-232 port by daisy-chaining a master drive to other drives using CAN cables. In the CAN protocol, address 0 is reserved for the CAN master and thereafter all other nodes on a CAN network must have unique, non-zero addresses. When the *Xenus Micro* CAN address is set to 0, it acts as a CAN master, converting the RS-232 data into CAN messages and passing it along to the other drives which act as CAN nodes, each having a unique non-zero CAN address.

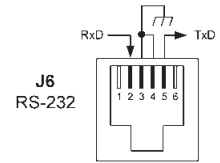

CAN

Xenus Micro uses the CAN physical layer signals CANH, CANL, and GND for connection, and CANopen protocol for communication. The default address is 0 which is produced by [IN5~8] programmed to pull-down to ground, and a flash address of 0. Before installing the drive in a CAN system, it must be assigned a non-zero CAN address. A maximum of 127 CAN nodes are allowed on a single CAN bus. For installations with sixteen or more CAN nodes on a network *CME 2* can be used to configure *Xenus Micro* to use a combination of digital inputs and programmed offset in flash memory to configure the drive with a CAN node address.

ASCII COMMUNICATIONS

The Copley ASCII Interface is a set of ASCII format commands that can be used to operate and monitor Copley Controls Accelnet, Stepnet, and Xenus series amplifiers over an RS-232 serial connection. For instance, after basic amplifier configuration values have been programmed using *CME 2*, a control program can use the ASCII Interface to:

- Enable the amplifier in Programmed Position mode.
- Home the axis.
- Issue a series of move commands while monitoring position, velocity, and other run-time variables.

Additional information can be found in the ASCII Programmers Guide on the Copley website:

http://www.copleycontrols.com/motion/downloads/pdf/ASCII_ProgrammersGuide.pdf

CAN STATUS LED

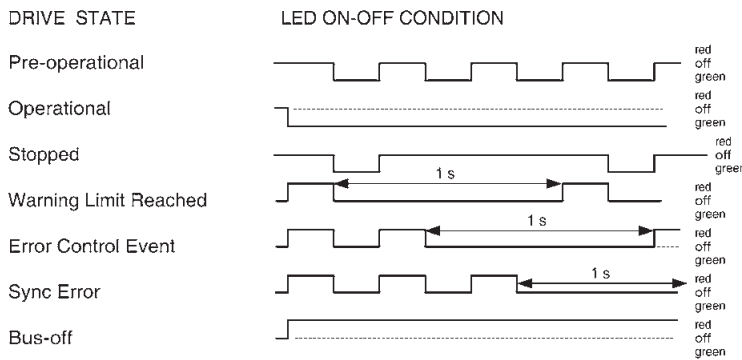

Drive Fault conditions:

- Over or under-voltage
- Motor over-temperature
- Encoder +5 Vdc fault
- Short-circuits from output to output
- Short-circuits from output to ground
- Internal short circuits
- Drive over-temperature

Faults are programmable to be either transient or latching

Note: Red & green led on-times do not overlap.
LED color may be red, green, off, or flashing of either color.

DRIVE STATUS LED

A single bi-color LED gives the state of the drive by changing color, and either blinking or remaining solid.

The possible color and blink combinations are:

- **Green/Solid:** Drive OK and enabled. Will run in response to reference inputs or CANopen commands.
- **Green/Slow-Blinking:** Drive OK but NOT-enabled. Will run when enabled.
- **Green/Fast-Blinking:** Positive or Negative limit switch active. Drive will only move in direction not inhibited by limit switch.
- **Red/Solid:** Transient fault condition. Drive will resume operation when fault is removed.
- **Red/Blinking:** Latching fault. Operation will not resume until drive is Reset

COMMAND INPUTS

ANALOG TORQUE, VELOCITY, POSITION

A single ± 10 Vdc differential input connects to controllers that use PID or similar compensators, and output a current or velocity command to the drive. Drive output current or velocity vs. reference input voltage is programmable. In position-mode, the analog command is converted to a digital position reference based on a programmable ratio of encoder counts vs. input volts. When this is greater than the deadband, which is programmable down to 0 V, it is passed through velocity, acceleration, and deceleration limiters after which it becomes the input to the position loop.

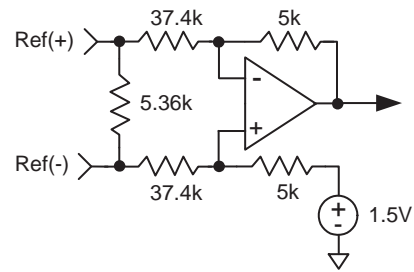

DIGITAL TORQUE, VELOCITY

Digital torque or velocity commands can be in either single-ended or differential format. Single-ended signals should be sourced from devices with active pull-up and pull-down to take advantage of the high-speed inputs. Differential inputs have 121 Ω line-terminators.

SINGLE-ENDED PWM & DIRECTION

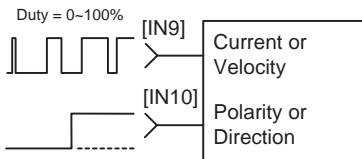

SINGLE-ENDED 50% PWM

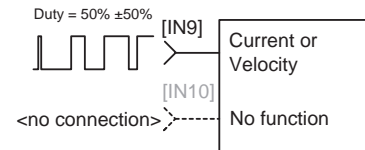

DIFFERENTIAL PWM & DIRECTION

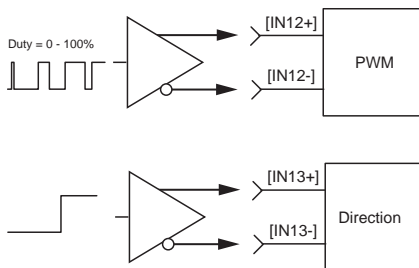

DIFFERENTIAL 50% PWM

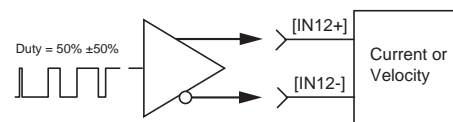

COMMAND INPUTS (CONT'D)

DIGITAL POSITION

Digital position commands can be in either single-ended or differential format. Single-ended signals should be sourced from devices with active pull-up and pull-down to take advantage of the high-speed inputs. Differential inputs have 121 Ω line-terminators.

SINGLE-ENDED PULSE & DIRECTION

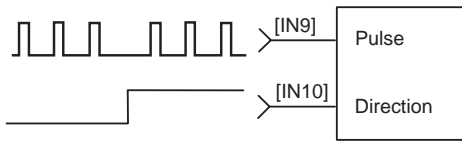

DIFFERENTIAL PULSE & DIRECTION

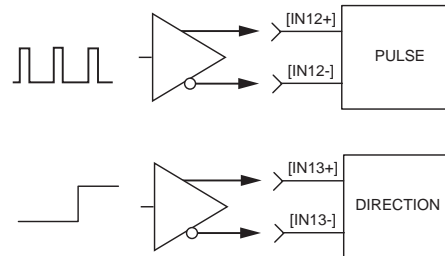

SINGLE-ENDED CU/CD

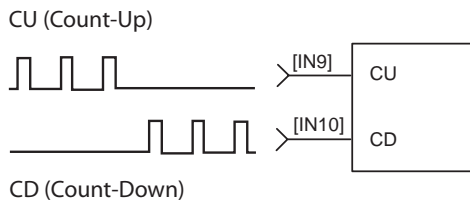

DIFFERENTIAL CU/CD

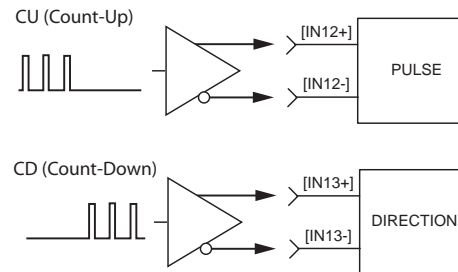

QUAD A/B ENCODER SINGLE-ENDED

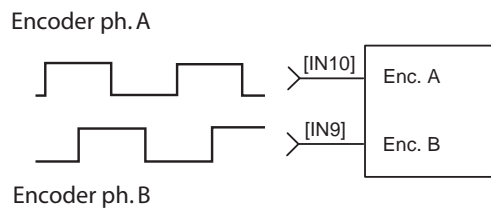

QUAD A/B ENCODER DIFFERENTIAL

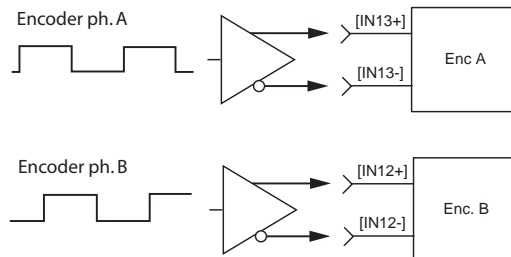

MULTI-MODE ENCODER PORT

This port consists of three differential input/output channels that take their functions from the Basic Setup of the drive. On drives with quad A/B encoder feedback, the port works as an output buffering the signals from the encoder. With resolver or sin/cos encoder versions, the feedback is converted to quad A/B signals with programmable resolution. These signals can then be fed back to an external motion controller that closes the position or velocity loops. As an input, the port can take quad A/B signals to produce a dual-loop position control system or use the signals as master-encoder feedback in camming mode. In addition, the port can take stepper command signals (CU/CD or Pulse/Direction) in differential format.

AS BUFFERED OUTPUTS FROM A DIGITAL QUADRATURE FEEDBACK ENCODER

When using a digital quadrature feedback encoder, the A/B/X signals drive the multi-mode port output buffers directly. This is useful in systems that use external controllers that also need the motor feedback encoder signals because these now come from J7, the Control connector. In addition to eliminating "Y" cabling where the motor feedback cable has to split to connect to both controller and motor, the buffered outputs reduce loading on the feedback cable that could occur if the motor encoder had to drive two differential inputs in parallel, each with it's own 121 ohm terminating resistor.

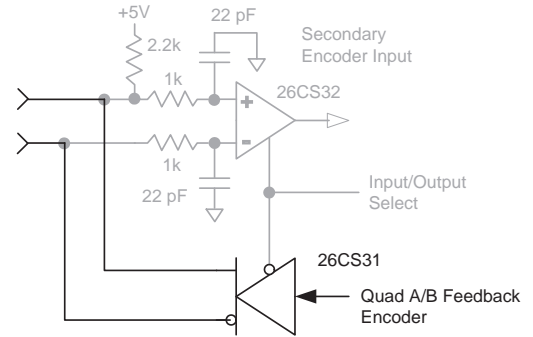

AS EMULATED QUAD A/B/X ENCODER OUTPUTS FROM AN ANALOG SIN/COS FEEDBACK ENCODER OR RESOLVER

Analog sin/cos or resolver signals are interpolated in the drive with programmable resolution. The incremental position data is then converted back into digital quadrature format which drives the multi-mode port output buffers. Some analog encoders also produce a digital index pulse which is connected directly to the port's output buffer. The result is digital quadrature A/B/X signals that can be used as feedback to an external control system. Resolver signals are interpolated with programmable resolution up to 14-bits per revolution (single-speed resolver).

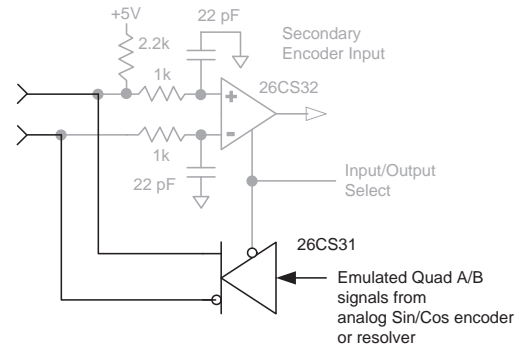

AS A MASTER OR CAMMING ENCODER INPUT FROM A DIGITAL QUADRATURE ENCODER

When operating in position mode the multi-mode port can accept digital command signals from external encoders. These can be used to drive cam tables, or as master-encoder signals when operating in a master/slave configuration.

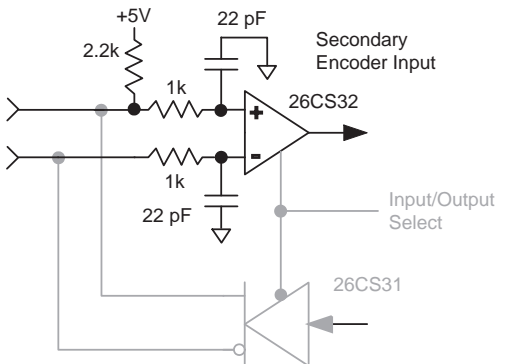

AS DIGITAL COMMAND INPUTS IN PULSE/DIRECTION, PULSE-UP/PULSE-DOWN, OR DIGITAL QUADRATURE ENCODER FORMAT

The multi-mode port can also be used when digital command signals are in a differential format. These are the signals that typically go to [IN9] and [IN10] when they are single-ended. But, at higher frequencies these are likely to be differential signals in which case the multi-mode port can be used.

GP (GENERAL PURPOSE) DIGITAL INPUTS

There are fourteen digital inputs, thirteen of which have programmable functions. Input [IN1] is not programmable and is dedicated to the drive Enable function. This is done to prevent accidental programming of the input in such a way that the controller could not shut it down. Programmable functions of the digital inputs include:

- Amplifier Enable
- Positive Limit switch
- Negative Limit switch
- Drive Reset
- Motor over-temperature
- Home switch
- Motion Abort
- Reference input attenuation select (zero or divide by eight)
- PWM Sync Input
- CAN address
- PWM/Polarity or PWM 50% commands for current/velocity control
- Pulse/Direction or CW/CCW stepper pulses, or quad A/B encoder signals for position control and camming

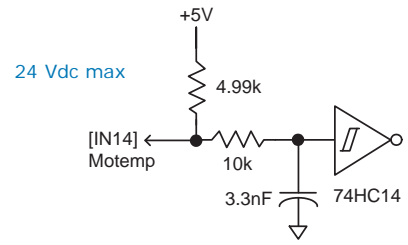
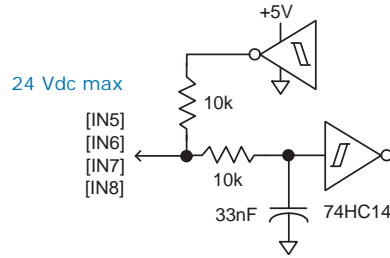
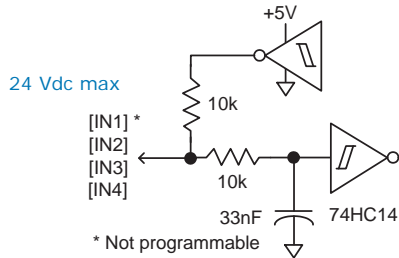

HS (HIGH SPEED) DIGITAL INPUTS

These are single-ended inputs with all the programmable functions of the GP inputs plus these additional functions on [IN9] & [IN10]:

- Position or Camming modes: Pulse/Direction, CU/CD, or A/B Quad encoder inputs
- Velocity or Current modes: PWM 50%, PWM & Direction
- PWM Sync

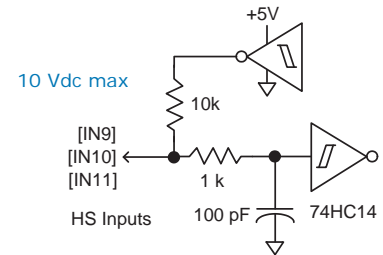

HSD (HIGH SPEED DIFFERENTIAL) DIGITAL INPUTS

These are differential inputs with programmable functions.

- Pulse/Direction, CU/CD, or A/B Quad encoder inputs
- Home switch
- Camming: Single-ended master encoder
Cam-table start input

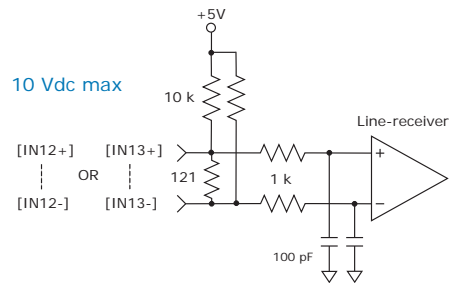

DIGITAL OUTPUTS

The digital outputs are open-drain MOSFETs with 1 kΩ pull-up resistors in series with a diode to +5 Vdc. They can sink up to 250 mAdc from external loads operating from power supplies to +30 Vdc. The output functions are programmable. The active state of the outputs is programmable to be on or off.

When driving inductive loads such as a relay, an external fly-back diode is required. The internal diode in the output is for driving PLC inputs that are opto-isolated and connected to +24 Vdc. The diode prevents conduction from +24 Vdc through the 1 kΩ resistor to +5 Vdc in the drive. This could turn the PLC input on, giving a false indication of the drive output state.

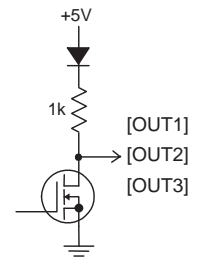

MOTOR BRAKE OUTPUT

This is an optically isolated output with a higher current rating for driving motor brakes. It can sink 1 Adc and has a flyback diode that is connected to the AuxHV input (+24 Vdc). Brake timing and function is programmable.

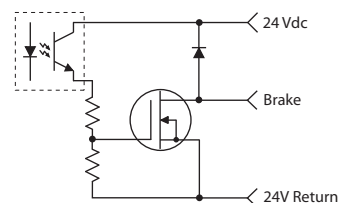

OUTPUT VOLTAGE LIMITS

The XSJ rectifies the AC mains power to produce an internal DC supply (HV). The rectified mains power is stored temporarily in a capacitor. As the load power increases, energy is drawn from the capacitor, discharging it until re-charged by the next cycle of the mains. Because the capacitor is only charged for a brief time at 2X the line frequency, the voltage will decrease between these charges producing "ripple" on the DC supply. As the motor voltage increases (a combination of BEMF (Back ElectroMotive Force) and voltage-drop across the motor's resistance) it eventually hits the bottom of the ripple voltage waveform on the DC supply.

This is called "clipping" as the output voltage can no longer increase to control motor current. The graph below shows the clipping voltages for the XSJ when operated at some common mains voltages over the range of output currents.

In order to avoid clipping, select a motor winding to provide some headroom between the clipping voltage and the expected terminal voltage to allow for low-line conditions on the mains, resistance changes in the motor due to heating, etc.

DC SUPPLY VOLTAGE AT LOW OUTPUT CURRENT AND POWER

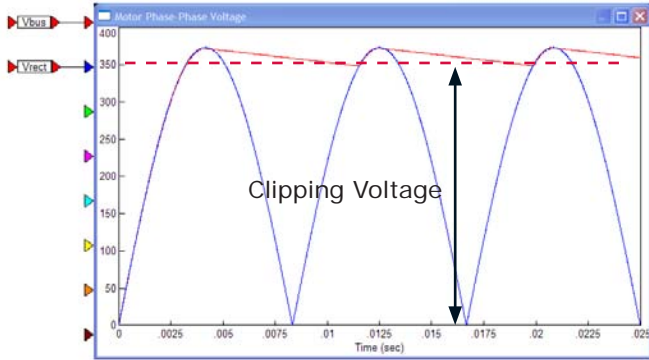

DC SUPPLY VOLTAGE AT HIGH OUTPUT CURRENT AND POWER

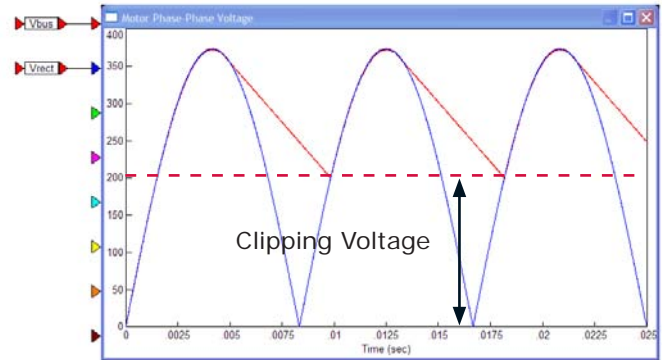

EXAMPLE

Assume 8 Adc is required to accelerate a linear motor to 2.5 m/s. Motor resistance is 12 Ω and BEMF constant is 36 V/m/s. The motor is brushless driven with sinusoidal commutation:

- 1) Find I*R voltage drop:
 $8 \text{ Adc} * 12 \Omega * 0.75 = 72 \text{ Vdc}$.

The 0.75 factor converts the line-line resistance of the motor to the effective resistance when commutating sinusoidally.

- 2) Find BEMF at 2.5 m/s: $36 \text{ V/m/s} * 2.5 \text{ m/s} = 90 \text{ Vdc}$
- 3) Find motor terminal voltage:
 $I * R + \text{BEMF} = 72 + 90 = 162 \text{ Vdc}$

4) The dotted lines on the graph to the right show the clipping voltages at 8 Adc. Operation at 240 Vac would give about 28 V of headroom. But, at 200 Vac, either the motor velocity or accelerating current would have to be reduced to avoid clipping.

Finally, note that the motor resistance will increase 29% if it heats from 25C to 100C. That would change the required terminal voltage to 183 Vdc. In general, allow 20~30% headroom between motor terminal voltage demand and the clipping voltage. Using the oscilloscope in CME 2 software, the bus voltage and motor terminal voltage can be displayed for a final determination of the headroom in the working machine.

CLIPPING VOLTAGE VS. OUTPUT CURRENT

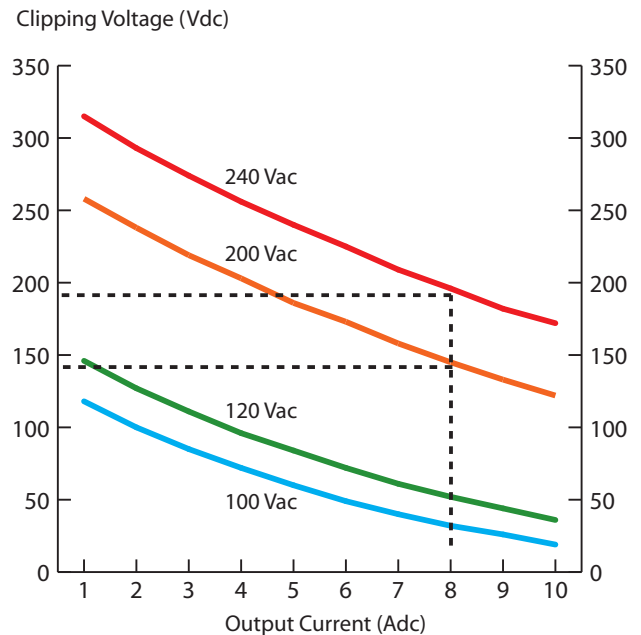

DRIVE CONNECTIONS

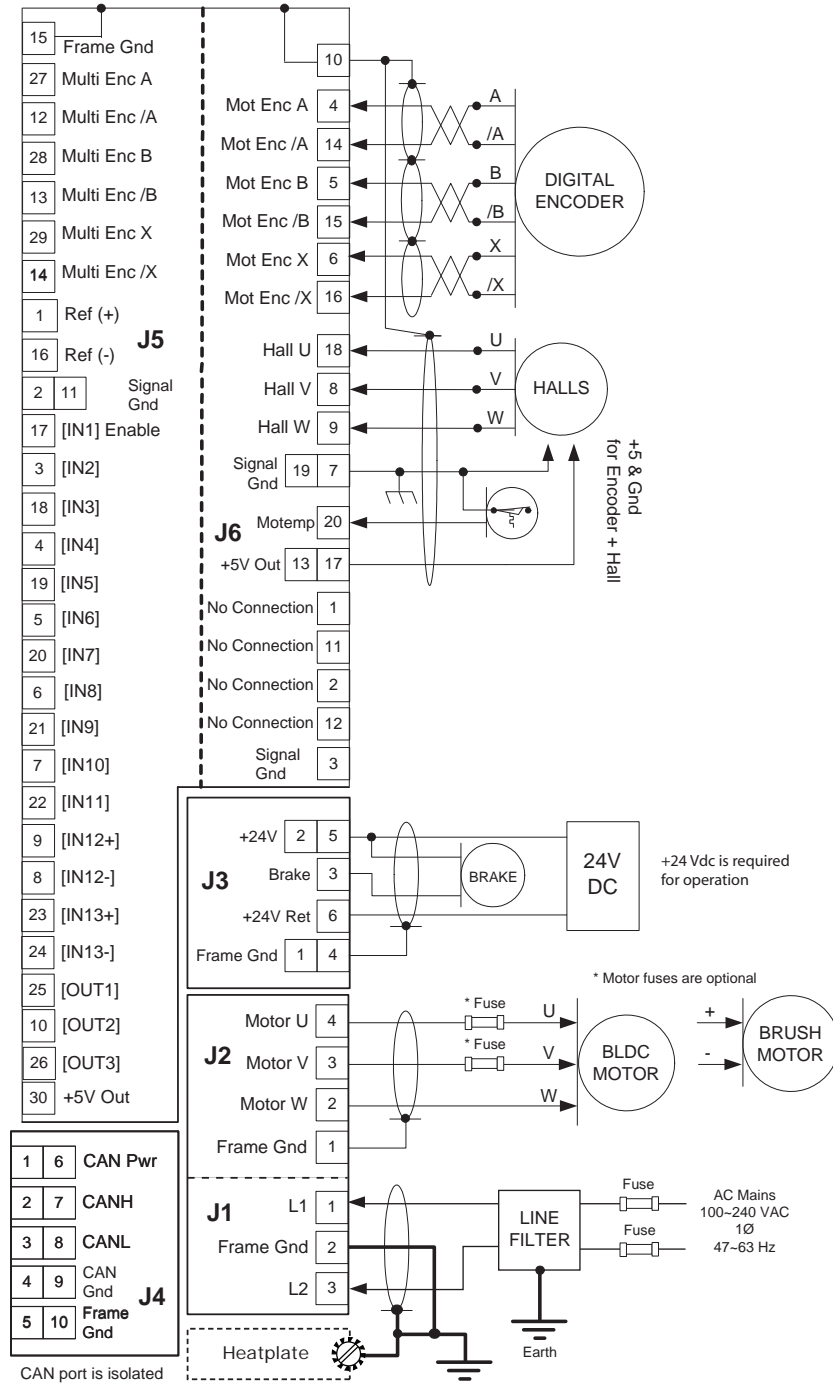

NOTES

1. The functions of input signals on J5-3,4,5,6,7,8-9,18,19,20,21,22,23-24, and are programmable.
2. The function of [IN1] on J5-17 is always Drive Enable and is not programmable.
The active level of [IN1] is programmable, and resetting the drive or clearing faults with changes on the enable input is programmable.
3. Pins J5-30, J6-13, and J6-17 connect to the same +5 Vdc @ 250 mAdc power source.
Total current drawn from all pins cannot exceed 250 mAdc.

CONNECTORS & SIGNALS

J1 Power	
Signal	Pin
L1	1
Frame Ground	2
L2	3

J1 Cable Connector:

Euro-style 5,0 mm pluggable male terminal block:

Wago: 721-103/026-047/RN01-0000
Insert/extract lever: Wago: 231-131

J2 Motor	
Signal	Pin
Frame Ground	1
Motor W	2
Motor V	3
Motor U	4

J2 Motor Cable Connector:

Euro-style 5,0 mm pluggable male terminal block:

Wago: 721-104/026-047/RN01-0000
Insert/extract lever: Wago: 231-131

J3 Brake, 24V Power			
Signal	Pin	Signal	
Brake	3	6	24V Return
+24Vdc	2	5	+24Vdc
Frame Gnd	1	4	Frame Gnd

J3 AuxHV/Brake Cable Connector:

6-position poke/crimp

Housing: Molex 43025-0600

Contact: Molex 43030-0008

Crimping tool: Molex 63811-2800

Contact extractor: Molex 11-03-0043

J4 CAN			
Signal	Pin	Signal	
Frame Ground	5	10	Frame Ground
Signal Ground	4	9	Signal Ground
CANL	3	8	CANL
CANH	2	7	CANH
CAN Power	1	6	CAN Power

CAN circuits are optically-isolated from drive circuits

J4 CAN Cable Connector:

10-position poke/crimp

Housing: Samtec IPD1-5-D

Contacts(20): Samtec CC79L-2024-01-F

Crimping tool: Samtec CAT-HT-179-2024-11

Contact Extractor: Samtec CAT-EX-179-01

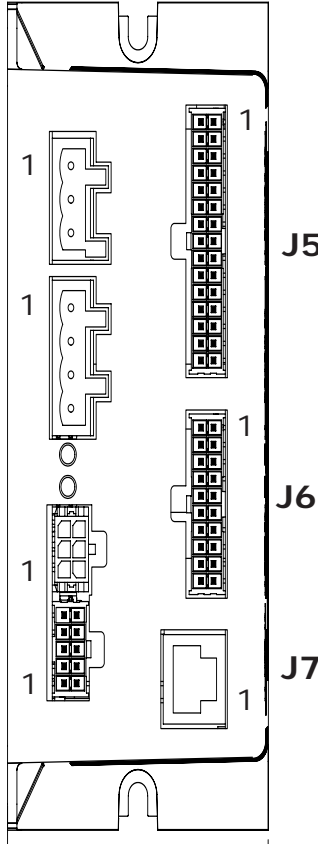

J5 Signal			
Signal	Pin	Pin	Signal
Analog Ref (-)	16	1	Analog Ref (+)
Enable Input [IN1]	17	2	Signal Ground
GP Input [IN3]	18	3	GP Input [IN2]
GP Input [IN5]	19	4	GP Input [IN4]
GP Input [IN7]	20	5	GP Input [IN6]
HS Input [IN9]	21	6	GP Input [IN8]
HS Input [IN11]	22	7	HS Input [IN10]
HS Input [IN13+]	23	8	HS Input [IN12-]
HS Input [IN13-]	24	9	HS Input [IN12+]
GP Output [OUT1]	25	10	GP Output [OUT2]
GP Output [OUT3]	26	11	Signal Ground
Multi-Mode Encoder A	27	12	Multi-Mode Encoder /A
Multi-Mode Encoder B	28	13	Multi-Mode Encoder /B
Multi-Mode Encoder X	29	14	Multi-Mode Encoder /X
+5 Vdc Output	30	15	Frame Ground

J5 Control Cable Connector:

30-position poke/crimp

Housing: Samtec IPD1-15-D

Contacts(30): Samtec CC79L-2024-01-F

Crimping tool: Samtec CAT-HT-179-2024-11

Contact Extractor: Samtec CAT-EX-179-01

J6 Feedback			
Signal	Pin	Pin	Signal
No Connection	11	1	No Connection
No Connection	12	2	No Connection
+5 Vdc Output	13	3	Signal Ground
Encoder /A	14	4	Encoder A
Encoder /B	15	5	Encoder B
Encoder /X	16	6	Encoder X
+5 Vdc Output	17	7	Signal Ground
Hall U	18	8	Hall V
Signal Ground	19	9	Hall W
Motemp [IN14]	20	10	Frame Ground

J6 Feedback Cable Connector:

20-position poke/crimp

Housing: Samtec IPD1-10-D

Contacts(30): Samtec CC79L-2024-01-F

Crimping tool: Samtec CAT-HT-179-2024-11

Contact Extractor: Samtec CAT-EX-179-01

J7 RS-232	
Pin	Signal
6	No Connect
5	TxD Output
4	Signal Ground
3	Signal Ground
2	RxD Input
1	No Connect

J7 RS-232 Cable Connector:

RJ-11 Modular type

6-position, 4 used

DRIVE CONNECTIONS

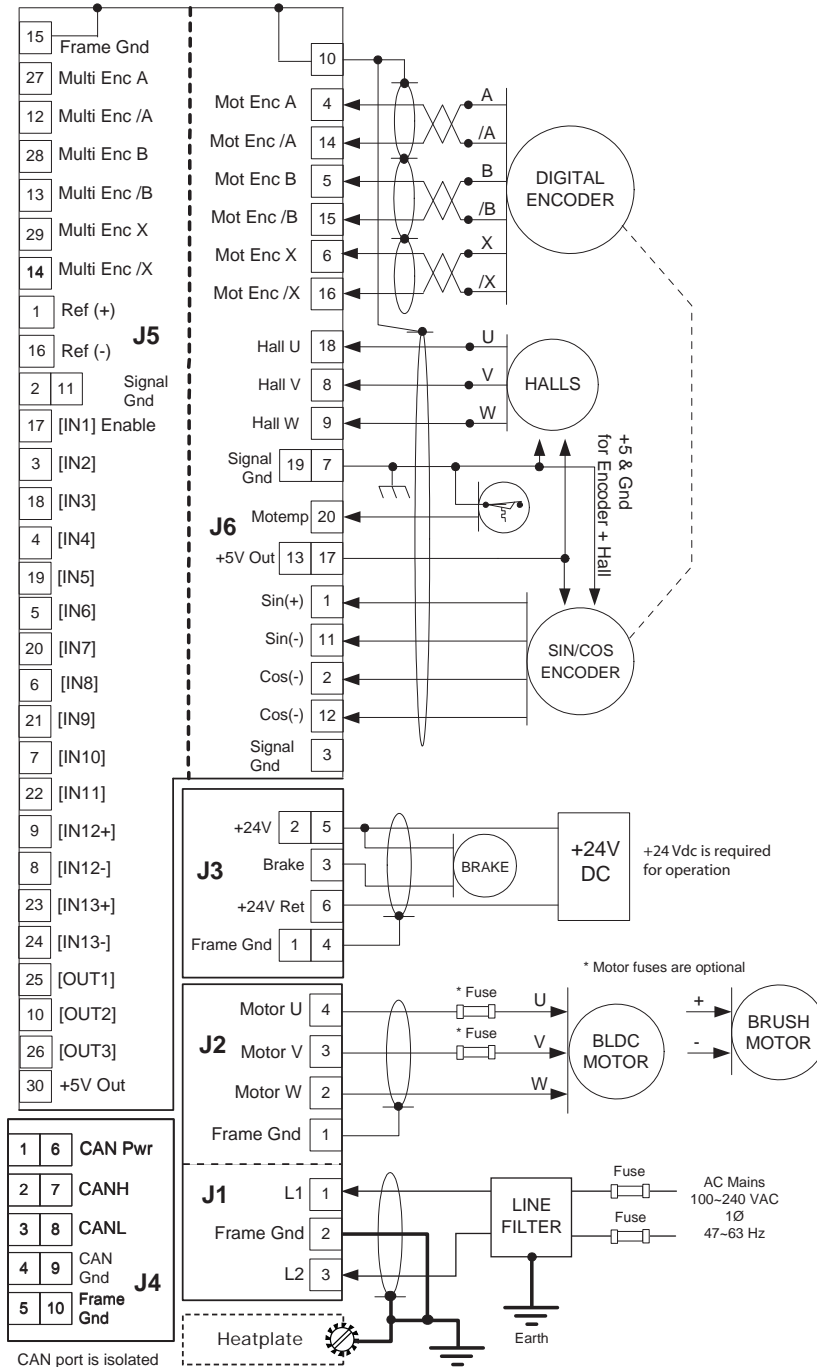

NOTES

- The functions of input signals on J5-3,4,5,6,7,8-9,18,19,20,21,22,23-24, and are programmable.
- The function of [IN1] on J5-17 is always Drive Enable and is not programmable.
The active level of [IN1] is programmable, and resetting the drive or clearing faults with changes on the enable input is programmable.
- Pins J5-30, J6-13, and J6-17 connect to the same +5 Vdc @ 250 mAdc power source.
Total current drawn from all pins cannot exceed 250 mAdc.

CONNECTORS & SIGNALS

J1 Power	
Signal	Pin
L1	1
Frame Ground	2
L2	3

J1 Cable Connector:

Euro-style 5,0 mm pluggable male terminal block:

Wago: 721-103/026-047/RN01-0000
Insert/extract lever: Wago: 231-131

J2 Motor	
Signal	Pin
Frame Ground	1
Motor W	2
Motor V	3
Motor U	4

J2 Motor Cable Connector:

Euro-style 5,0 mm pluggable male terminal block:

Wago: 721-104/026-047/RN01-0000
Insert/extract lever: Wago: 231-131

J3 Brake, 24V Power				
Signal	Pin	Signal	Pin	Signal
Brake	3	24V Return	6	
+24Vdc	2	+24Vdc	5	
Frame Gnd	1	Frame Gnd	4	

J3 AuxHV/Brake Cable Connector:

6-position poke/crimp

Housing: Molex 43025-0600
Contact: Molex 43030-0008
Crimping tool: Molex 63811-2800
Contact extractor: Molex 11-03-0043

J4 CAN			
Signal	Pin	Signal	Pin
Frame Ground	5	Frame Ground	10
Signal Ground	4	Signal Ground	9
CANL	3	CANL	8
CANH	2	CANH	7
CAN Power	1	CAN Power	6

CAN circuits are optically-isolated from drive circuits

J4 CAN Cable Connector:

10-position poke/crimp

Housing: Samtec IPD1-5-D
Contacts(20): Samtec CC79L-2024-01-F
Crimping tool: Samtec CAT-HT-179-2024-11
Contact Extractor: Samtec CAT-EX-179-01

J7 RS-232	
Pin	Signal
6	No Connect
5	TxD Output
4	Signal Ground
3	Signal Ground
2	RxD Input
1	No Connect

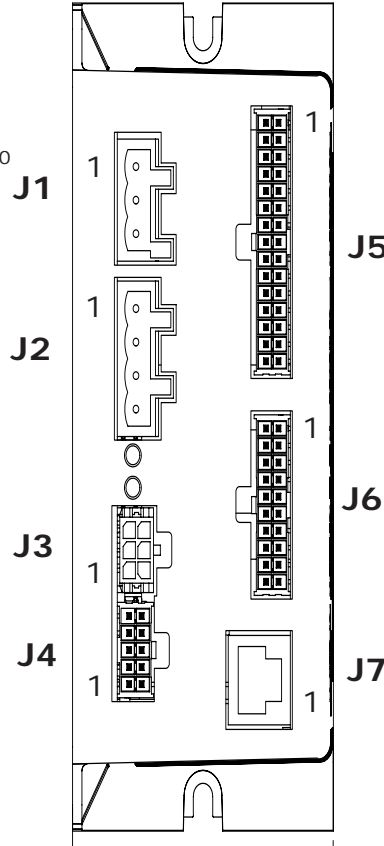

J5 Signal			
Signal	Pin	Pin	Signal
Analog Ref (-)	16	1	Analog Ref (+)
Enable Input [IN1]	17	2	Signal Ground
GP Input [IN3]	18	3	GP Input [IN2]
GP Input [IN5]	19	4	GP Input [IN4]
GP Input [IN7]	20	5	GP Input [IN6]
HS Input [IN9]	21	6	GP Input [IN8]
HS Input [IN11]	22	7	HS Input [IN10]
HS Input [IN13+]	23	8	HS Input [IN12-]
HS Input [IN13-]	24	9	HS Input [IN12+]
GP Output [OUT1]	25	10	GP Output [OUT2]
GP Output [OUT3]	26	11	Signal Ground
Multi-Mode Encoder A	27	12	Multi-Mode Encoder /A
Multi-Mode Encoder B	28	13	Multi-Mode Encoder /B
Multi-Mode Encoder X	29	14	Multi-Mode Encoder /X
+5 Vdc Output	30	15	Frame Ground

J5 Control Cable Connector:

30-position poke/crimp

Housing: Samtec IPD1-15-D

Contacts(30): Samtec CC79L-2024-01-F

Crimping tool: Samtec CAT-HT-179-2024-11

Contact Extractor: Samtec CAT-EX-179-01

J6 Feedback			
Signal	Pin	Pin	Signal
Sin(-)	11	1	Sin(+)
Cos(-)	12	2	Cos(+)
+5 Vdc Output	13	3	Signal Ground
Encoder /A	14	4	Encoder A
Encoder /B	15	5	Encoder B
Encoder /X	16	6	Encoder X
+5 Vdc Output	17	7	Signal Ground
Hall U	18	8	Hall V
Signal Ground	19	9	Hall W
Motemp [IN14]	20	10	Frame Ground

J6 Feedback Cable Connector:

20-position poke/crimp

Housing: Samtec IPD1-10-D

Contacts(30): Samtec CC79L-2024-01-F

Crimping tool: Samtec CAT-HT-179-2024-11

Contact Extractor: Samtec CAT-EX-179-01

J7 RS-232 Cable Connector:

RJ-11 Modular type

6-position, 4 used

DRIVE CONNECTIONS

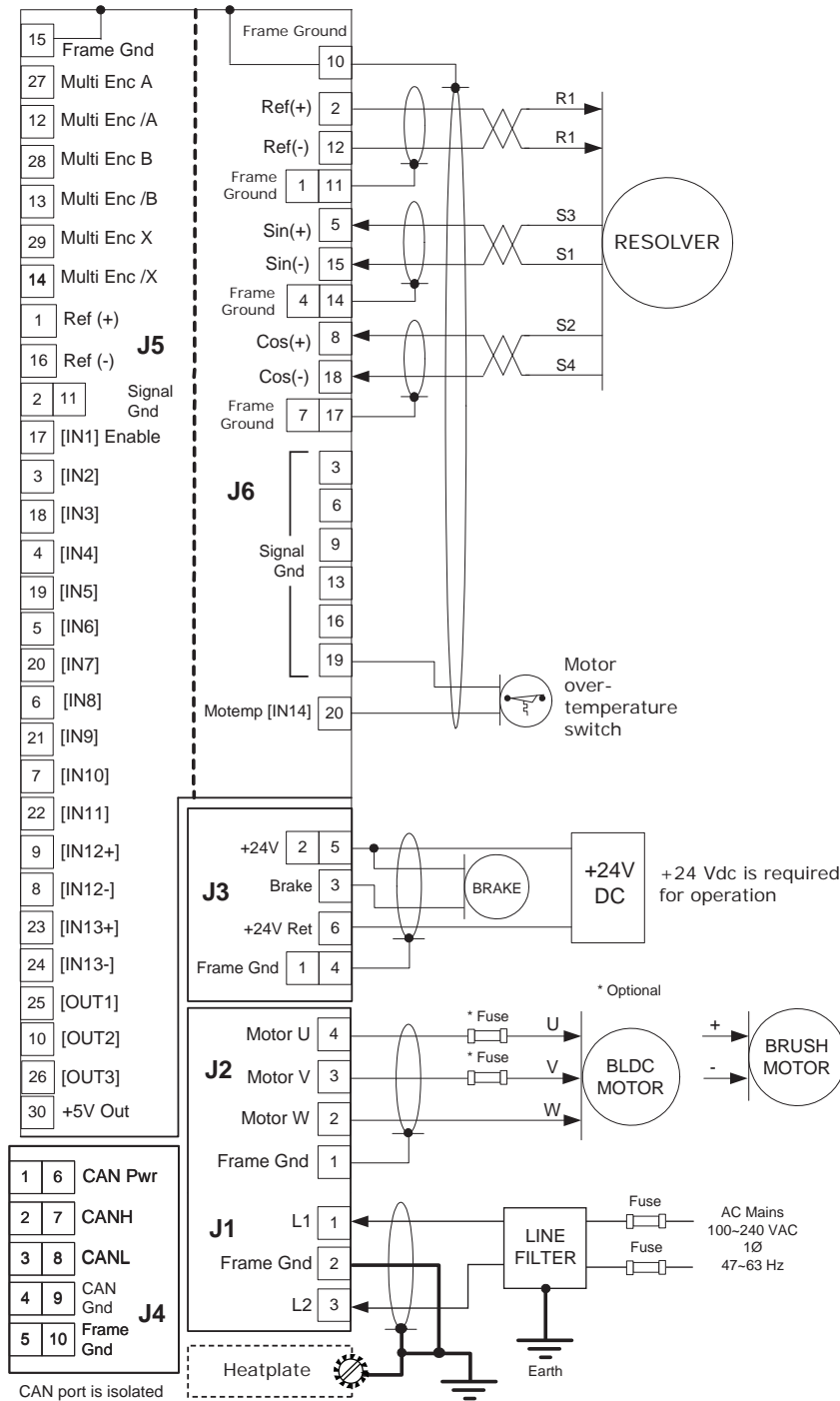

NOTES

1. The functions of input signals on J5-3,4,5,6,7,8-9,18,19,20,21,22,23-24, and are programmable.
2. The function of [IN1] on J5-17 is always Drive Enable and is not programmable.
The active level of [IN1] is programmable, and resetting the drive or clearing faults with changes on the enable input is programmable.

CONNECTORS & SIGNALS

J1 Power	
Signal	Pin
L1	1
Frame Ground	2
L2	3

J1 Cable Connector:

Euro-style 5,0 mm pluggable male terminal block:

Wago: 721-103/026-047/RN01-0000
Insert/extract lever: Wago: 231-131

J2 Motor	
Signal	Pin
Frame Ground	1
Motor W	2
Motor V	3
Motor U	4

J2 Motor Cable Connector:

Euro-style 5,0 mm pluggable male terminal block:

Wago: 721-104/026-047/RN01-0000
Insert/extract lever: Wago: 231-131

J3 Brake, 24V Power			
Signal	Pin	Signal	Pin
Brake	3	24V Return	6
+24Vdc	2	+24Vdc	5
Frame Gnd	1	Frame Gnd	4

J3 AuxHV/Brake Cable Connector:

6-position poke/crimp

Housing: Molex 43025-0600
Contact: Molex 43030-0008
Crimping tool: Molex 63811-2800
Contact extractor: Molex 11-03-0043

J4 CAN			
Signal	Pin	Signal	Pin
Frame Ground	5	Frame Ground	10
Signal Ground	4	Signal Ground	9
CANL	3	CANL	8
CANH	2	CANH	7
CAN Power	1	CAN Power	6

CAN circuits are optically-isolated from drive circuits

J4 CAN Cable Connector:

10-position poke/crimp

Housing: Samtec IPD1-5-D
Contacts(20): Samtec CC79L-2024-01-F
Crimping tool: Samtec CAT-HT-179-2024-11
Contact Extractor: Samtec CAT-EX-179-01

J7 RS-232	
Pin	Signal
6	No Connect
5	TxD Output
4	Signal Ground
3	Signal Ground
2	RxD Input
1	No Connect

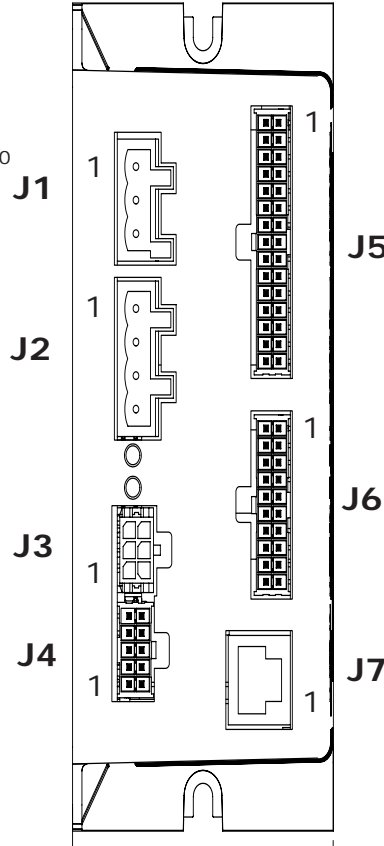

J5 Signal			
Signal	Pin	Pin	Signal
Analog Ref (-)	16	1	Analog Ref (+)
Enable Input [IN1]	17	2	Signal Ground
GP Input [IN3]	18	3	GP Input [IN2]
GP Input [IN5]	19	4	GP Input [IN4]
GP Input [IN7]	20	5	GP Input [IN6]
HS Input [IN9]	21	6	GP Input [IN8]
HS Input [IN11]	22	7	HS Input [IN10]
HS Input [IN13+]	23	8	HS Input [IN12-]
HS Input [IN13-]	24	9	HS Input [IN12+]
GP Output [OUT1]	25	10	GP Output [OUT2]
GP Output [OUT3]	26	11	Signal Ground
Multi-Mode Encoder A	27	12	Multi-Mode Encoder /A
Multi-Mode Encoder B	28	13	Multi-Mode Encoder /B
Multi-Mode Encoder X	29	14	Multi-Mode Encoder /X
+5 Vdc Output	30	15	Frame Ground

J5 Control Cable Connector:

30-position poke/crimp

Housing: Samtec IPD1-15-D
Contacts(30): Samtec CC79L-2024-01-F
Crimping tool: Samtec CAT-HT-179-2024-11
Contact Extractor: Samtec CAT-EX-179-01

J6 Feedback			
Signal	Pin	Pin	Signal
Frame Ground	11	1	Frame Ground
Output R2 Ref(-)	12	2	Ref(+) Output R1
Signal Ground	13	3	Signal Ground
Frame Ground	14	4	Frame Ground
Input S1 Sin(-)	15	5	Sin(+) Input S3
Signal Ground	16	6	Signal Ground
Frame Ground	17	7	Frame Ground
Input S4 Cos(-)	18	8	Cos(+) Input S2
Signal Ground	19	9	Signal Ground
Motemp [IN14]	20	10	Frame Ground

J6 Feedback Cable Connector:

20-position poke/crimp

Housing: Samtec IPD1-10-D
Contacts(30): Samtec CC79L-2024-01-F
Crimping tool: Samtec CAT-HT-179-2024-11
Contact Extractor: Samtec CAT-EX-179-01

J7 RS-232 Cable Connector:

RJ-11 Modular type
6-position, 4 used

CABLING FOR COMMUNICATIONS

RS-232

The Serial Cable Kit (SER-CK) is a complete cable assembly that connects a computer serial port (COM1, COM2) to the drive. The adapter plugs into a PC's COMM port that supports RS-232 and accepts a modular cable that connects the adapter to the drive's J7.

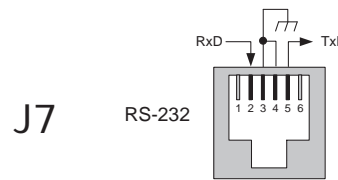
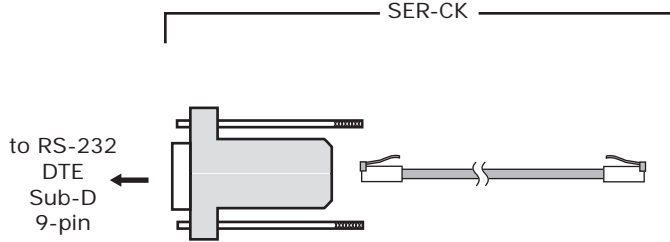

*Note: Computers & drives are both DTE devices.
RxD (Received Data) signals are inputs.
TxD (Transmitted Data) signals are outputs.*

CANOPEN

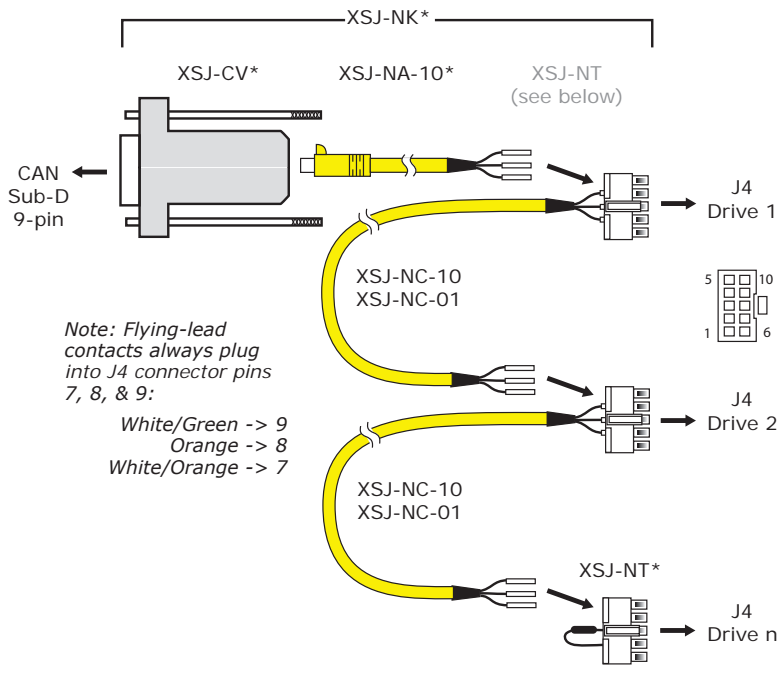
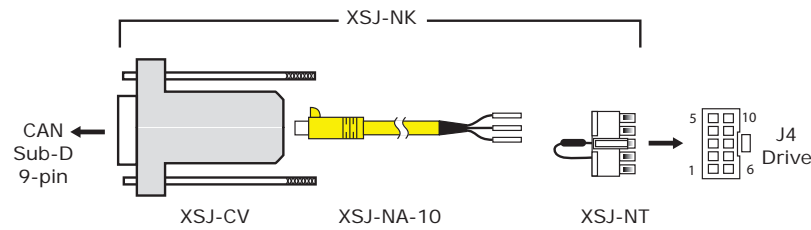

The connector kit for CAN networking (XSJ-NK) provides the parts to connect to a single drive. To use it, the flying leads must be poked into the XSJ-NT (see table for pins). The XSJ-NT comprises the a plug for drive J4 and also a 121 Ω resistor for the CAN bus terminator. The flying leads are left unattached so that the kit can also be used with multiple drives. When this is done, the CAN cables are daisy-chained from drive to drive and the XSJ-NT is only used on the last drive in the chain. The cables used for the daisy-chain are the XSJ-NC-10 or XSJ-NC-01 which have a J4 connector attached to a cable with flying leads and crimps.

XSJ-NK Connections		
D-Sub 9F	Pin	Wire Color
CAN_GND	7	White/Green
CAN_L	3	Orange
CAN_H	2	White/Orange

Note: D-Sub 9F connections comply with CAN CiA DR-303-1

XSJ-NC-01(-10) Connections				
Wire Color	Drive J4 Cable Connector			
	Frame Gnd	5	10	Frame Gnd
White Green	CAN_GND	4	9	CAN_GND
Orange	CAN_L	3	8	CAN_L
White/Orange	CAN_H	2	7	CAN_H
	CAN_V+	1	6	CAN_V+

XSJ-NT Connections			
Drive J4 Cable Connector			
Frame Gnd	5	10	Frame Gnd
CAN_GND	4	9	CAN_GND
121 Ω Terminator Connects	3	8	CAN_L
	2	7	CAN_H
CAN_V+	1	6	CAN_V+

CABLING FOR COMMUNICATIONS

MULTI-DROP RS-232

The RS-232 specification does not support multi-drop (multiple device) connections as does RS-485 or CAN. However, it is possible to address multiple CAN-enabled Copley drives from a single RS-232 port. First, an RS-232 connection is made between the computer and drive #1 which must be given a CAN address of 0. Under normal CAN operation, this address is not allowed for CAN nodes. But, in this case, drive #1 will act as a CAN master and so address 0 is allowed. Next, CAN connections are made between drive #1, drive #2, and so on in daisy-chain fashion to the last drive. The first and last drives in the chain must have the 121 Ω resistor between the CAN_H and CAN_L signals to act as a line-terminator. Finally, the CAN addresses of the drives downstream from drive #1 are set to unique numbers, none of which can be 0.

When ASCII data is exchanged over the serial port, the commands are now preceded with the node address of the drive. Drive #1 converts the data into CAN data which is then sent to all of the drives in the chain. It now appears as though all drives in the chain are connected to the single RS-232 port in the computer and for that reason we refer it as *multi-drop* RS-232.

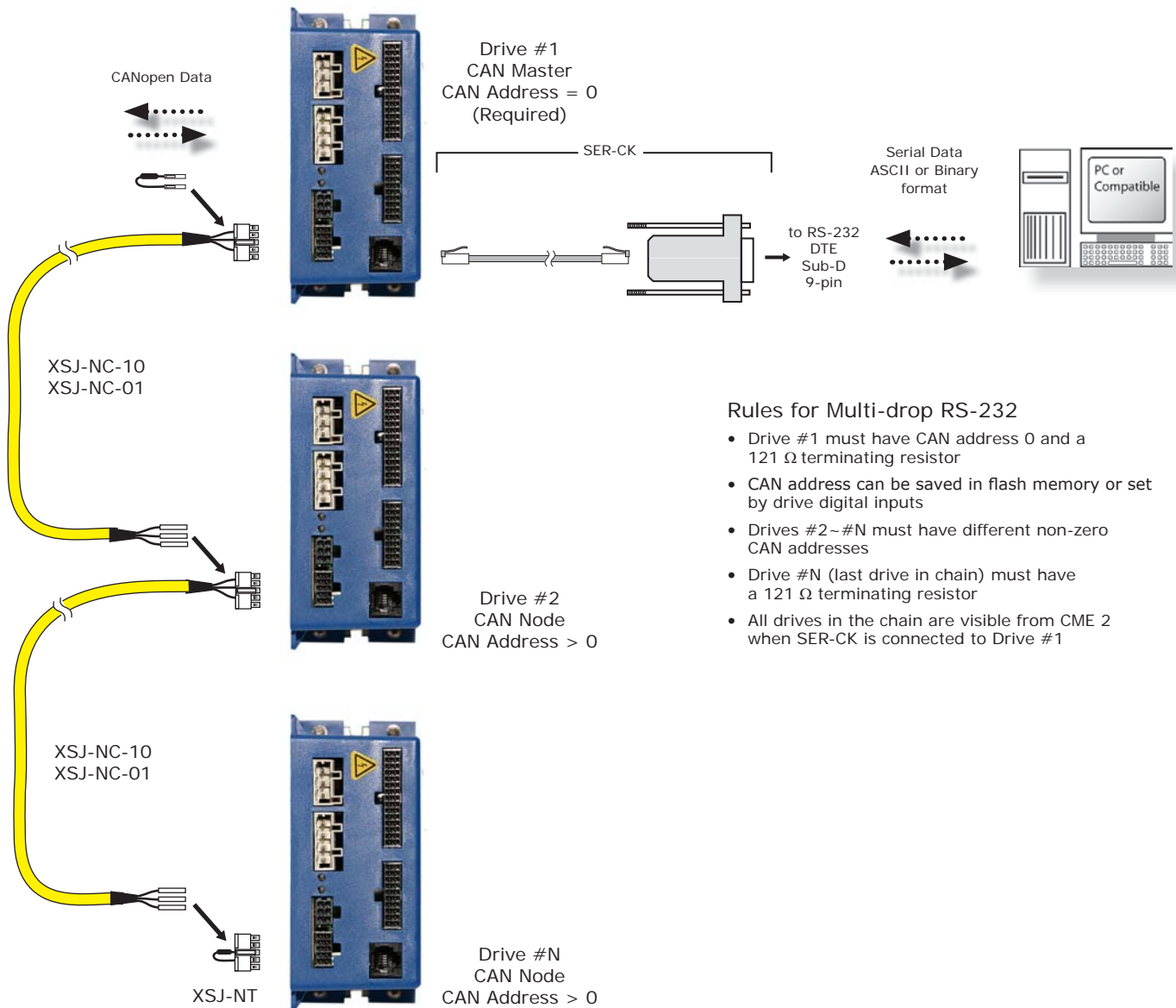

STAND-ALONE OPERATION

Drive takes digital position commands in Pulse/Direction, or CW/CCW format from an external controller or quadrature encoder signals from a master-encoder for electronic gearing. Velocity or torque control can be from ± 10 Vdc or digital PWM signals. *CME 2* used for setup and configuration.

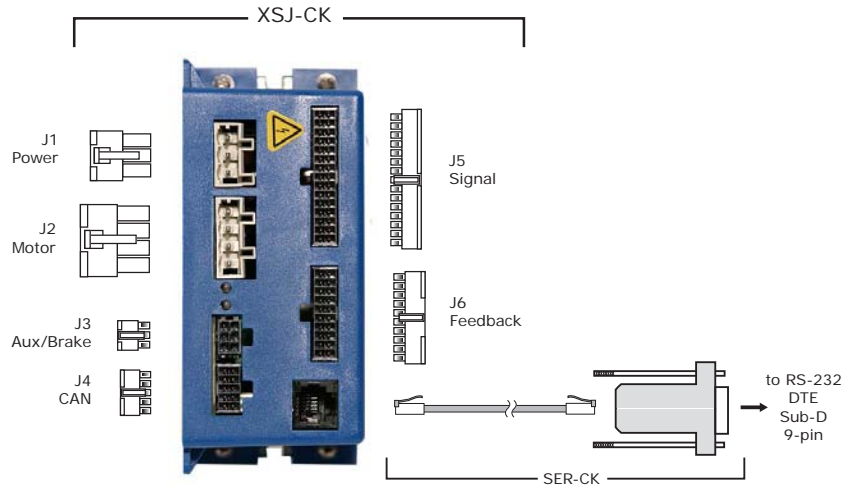

- Notes:
1. The XSJ-CK kit contains connector shells and crimp-contacts for J3-J6.
 2. Crimp-contacts are not shown
 3. The SER-CK Serial Cable Kit is not part of the XSJ-CK kit.

SINGLE-DRIVE SETUP FOR CANOPEN CONTROL

Drive operates as a CAN node. All commands are passed on the CAN bus. *CME 2* is used for setup and configuration before installation as CAN node.

Rules for Single-Drive CANopen Operation

- Drive CAN address must be > 0
- CAN address can be saved in flash memory or set by drive digital inputs
- Drive must have a 121Ω terminating resistor

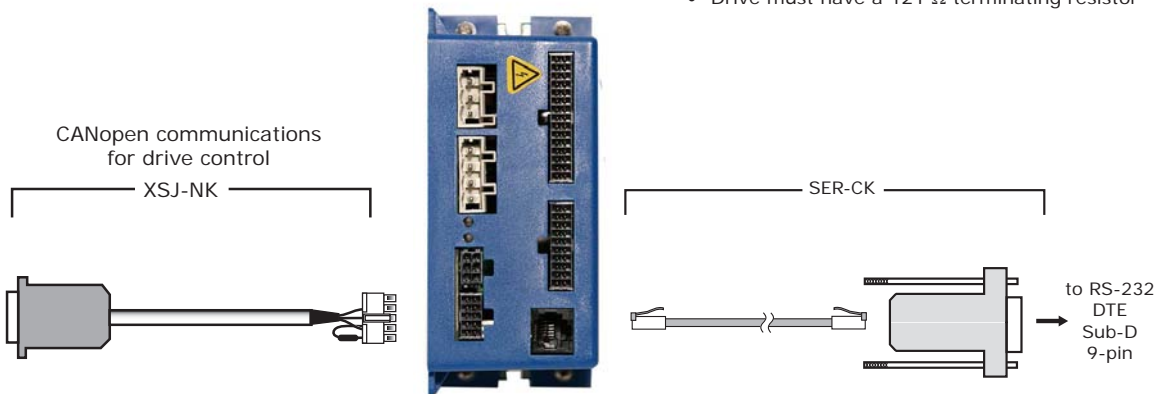

MULTIPLE-DRIVE SETUP FOR CANOPEN CONTROL

Rules for Multiple-Drive CANopen Operation

- All drives must have CAN addresses > 0 and no drives can have the same CAN address
- CAN address can be saved in flash memory or set by drive digital inputs
- Drive #N (last drive in chain) must have a 121 Ω terminating resistor
- CME 2 can only see the drive to which the SER-CK serial cable is connected
- The CAN Master must have a 121 Ω terminating resistor

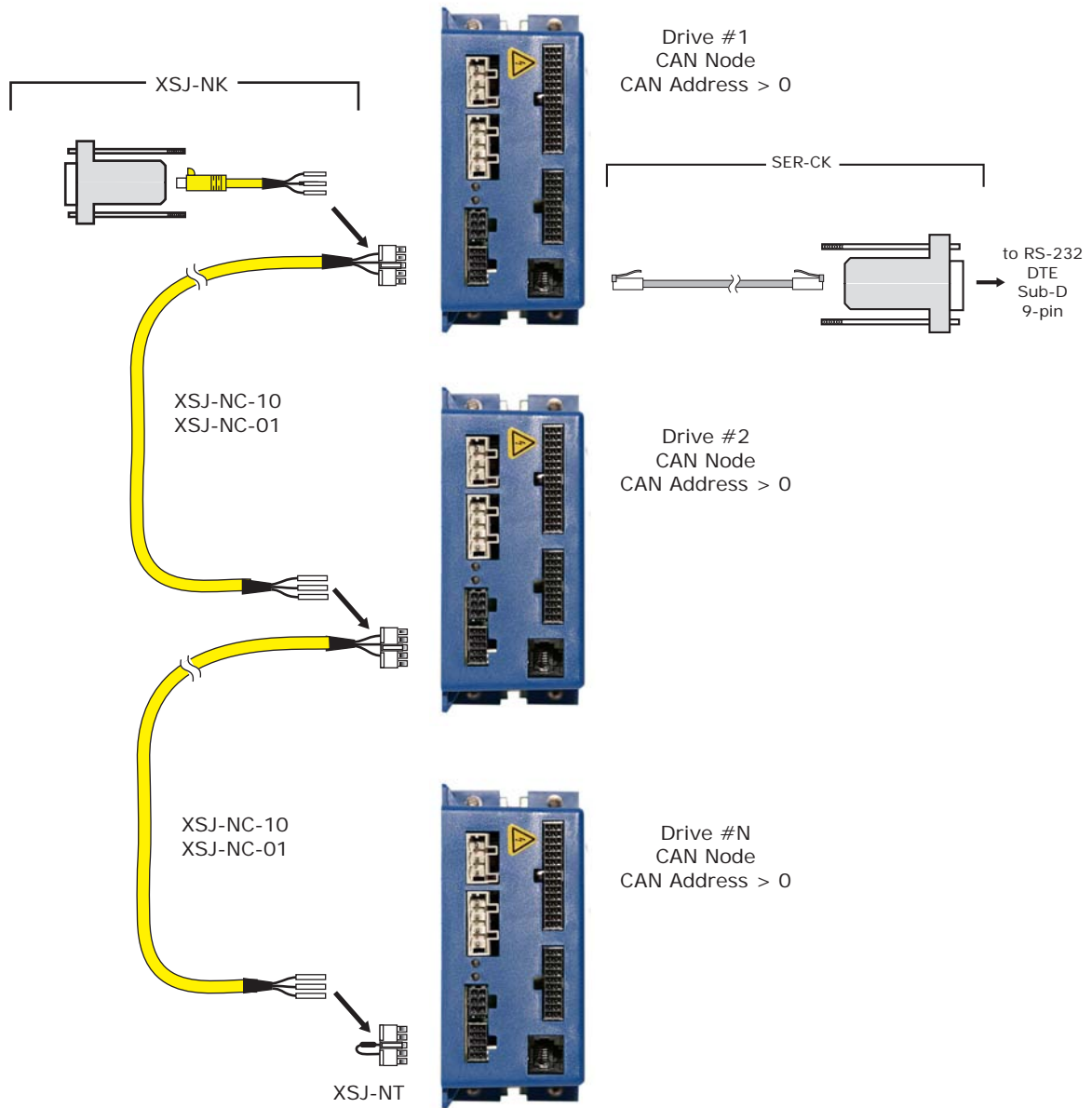

MOUNTING AND COOLING

The ability of the drive to output current at a particular ambient temperature is greatly affected by the way it is mounted and the way that air circulates across the heatplate which is the primary path for heat flow between the internal transistors and the environment. Thermal resistance is a measure of the temperature difference between the transistors and the environment per Watt of power dissipation. The data on this page show the thermal resistance under different mounting and cooling configurations.

INFINITE HEATSINK

The mounting surface is large enough so that its temperature does not change when absorbing the heat from the drive. Thermal grease is applied to the drive heatplate.



Thermal Resistance
0.23 °C-W

PANEL MOUNTED, ENCLOSED

Enameled steel panel in an industrial enclosure. No fan to circulate air in box or to force ambient air through box. A common mounting means for industrial machinery.



Thermal Resistance
1.91 °C/W

Test box dimensions:
Panel: 17x14.5 in (432x368 mm)
Box: 20x16 x 8.62 in
(508x406x219 mm)

FAN COOLED HEATSINK

A fan is mounted close to the heatsink and air velocity is ~400 LFM (~2 m/s).



Thermal Resistance
2.00 °C/W

FAN COOLED, NO HEATSINK

Forced-air at 400 LFM (Linear Feet/Minute) directed at the heatplate.



Thermal Resistance
2.9 °C/W

HEATSINK, CONVECTION COOLED

A heatsink is mounted to the heatplate and is exposed for convection cooling but is not fan cooled or in contact with a heat sinking surface.



Thermal Resistance
4.27 °C/W

NO HEATSINK OR FAN, CONVECTION COOLED

The heatplate is exposed for convection cooling but is not fan cooled or in contact with a heat sinking surface.



Thermal Resistance:
Flat: 6.5 °C/W
On edge: 6.0 °C/S

Flat mounting

MAXIMUM AMBIENT TEMPERATURE VS. OUTPUT CURRENT, MOUNTING, AND COOLING

The graphs below show the maximum ambient operating temperature for the drive vs. output current for the *Xenus Micro* models at 240 Vac mains voltages and under different mounting and cooling conditions.

XSJ-230-10

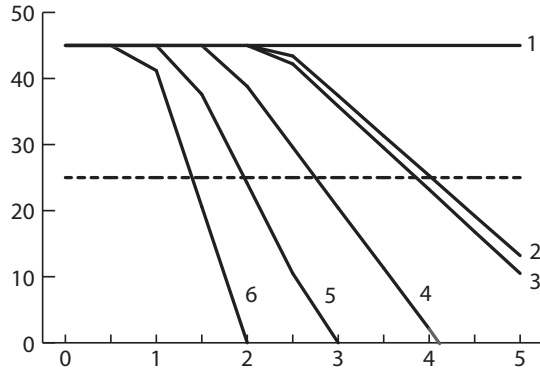

Curves:

- 1) Infinite heatsink
- 2) On steel panel in box
- 3) Heatsink, fan-cooled
- 4) No heatsink, fan-cooled
- 5) Heatsink, convection
- 6) No heatsink, convection

XSJ-230-06

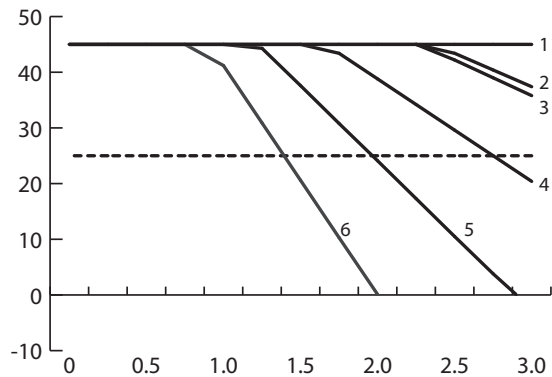

Curves:

- 1) Infinite heatsink
- 2) On steel panel in box
- 3) Heatsink, fan-cooled
- 4) No heatsink, fan-cooled
- 5) Heatsink, convection
- 6) No heatsink, convection

XSJ-230-02

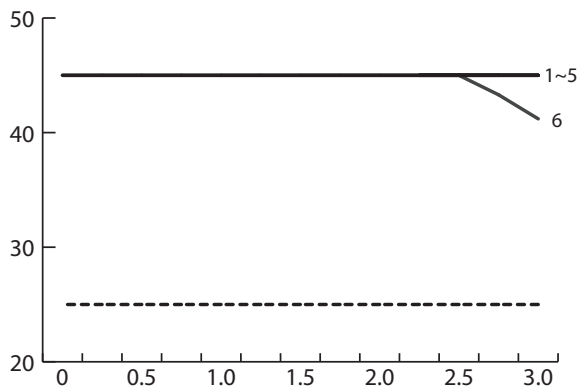

Curves:

- 1) Infinite heatsink
- 2) On steel panel in box
- 3) Heatsink, fan-cooled
- 4) No heatsink, fan-cooled
- 5) Heatsink, convection
- 6) No heatsink, convection

MASTER ORDERING GUIDE Add -S to model number for sin/cos feedback
Add -R to model number for resolver feedback

XSJ-230-02	<i>Xenus Micro Panel Servo drive 1/2 Adc</i>
XSJ-230-06	<i>Xenus Micro Panel Servo drive 3/6 Adc</i>
XSJ-230-10	<i>Xenus Micro Panel Servo drive 5/10 Adc</i>

ACCESSORIES

	QTY	REF	DESCRIPTION	MANUFACTURER PART NO.
Drive Connector Kit XSJ-CK	1	J1	Plug, 3 position, 5.0mm, female	Wago: 51117974 or 721-103/026-047/RN01-0000
	1	J2	Plug, 4 position, 5.0 mm, female	Wago: 51118008 or 721-104/026-047/RN01-0000
	1	J3	Connector housing, 6 position	Molex: Micro-Fit 43025-0600
	1	J4	Connector housing, 10 position	Samtec: Mini-Mate IPD1-05-D
	1	J5	Connector housing, 30 position	Samtec: Mini-Mate IPD1-15-D
	1	J6	Connector housing, 20 position	Samtec: Mini-Mate IPD1-10-D
	66	J4,J5,J6	Contact, female, for AWG 24~20 wire	Samtec: Mini-Mate CC79L-2024-01-F
	8	J3	Contact, female, for AWG 24~20 wire	Molex: Micro-Fit 43030-0008
	2	J1,J2	Wire insertion/extraction tool	Wago: 231-131
CANopen Connector Kit XSJ-NK	1	J1	D-Sub 9 position female to RJ-45 female (XSJ-CV)	
	1		RJ-45 plug to flying leads with crimps (XSJ-NA-10), 10 ft (3 m)	
	1		CANopen terminator (XSJ-NT) (J1 plug with resistor)	
XSJ-NA-10		J4	CANopen cable assembly: RJ-45 plug to flying leads with crimps, 10 ft (3 m)	
XSJ-NC-10		J4	CANopen cable assembly: drive J4 plug to flying leads with crimps , 10 ft (3 m)	
XSJ-NC-01		J4	CANopen cable assembly: drive J4 plug to flying leads with crimps , 1 ft (0.3 m)	
XSJ-NT		J4	CANopen network terminator (J4 plug with resistor)	
SER-CK		J7	Serial Cable Kit: D-Sub 9F to RJ-11 adapter + 6 ft (1.8 m) modular cable for drive J7	
XSJ-CV		J4	Cable adapter: D-Sub 9F to RJ-45 female, for CAN cables	
CME 2			CME 2™ CD (CME 2)	
Heatsink Kit XSJ-HK	1		Heatsink	
	1		Thermal Material	
		A/R	Hardware	

ORDERING EXAMPLE

Example: Order 1 XSJ-230-10 drive with resolver feedback, heatsink, and associated components:

Qty	Item	Remarks
1	XSJ-230-10-R	<i>Xenus Micro</i> servo drive
1	XSJ-HK	Heatsink kit
1	XSJ-CK	Connector Kit
1	SER-CK	Serial Cable Kit
1	CME2	CME 2™ CD

ADD A CAN BUS INTERFACE TO YOUR COMPUTER:

Copley's CAN-PCI-02 provides two fully-isolated CAN channels in a PCI-card form-factor and works with the XSJ-NK connector kit.

