

**FEATURES**

- Vertical Holding Brake
- Holding Force > 200N
- 24 Volt DC Supply
- Fail Safe Operation

**APPLICATIONS**

- Packaging
- Material Handling
- Automated Assembly

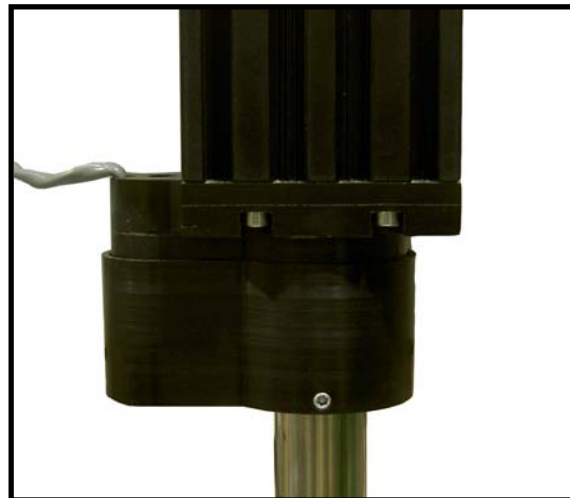

**THE OEM ADVANTAGE**

- High holding force in small package
- Reliable and cost-effective
- No maintenance or adjustment

**OVERVIEW**

The ServoTube brake provides a solution to power down parking of vertical axes and controlled deceleration of axes during power fail conditions. The brake is a bolt-on addition to any STA25 or XTR25 forcer and is IP67 rated. It is a unidirectional self-jamming design, which uses the motor’s motion to create the necessary forces for braking the system. To minimize size, the brake is designed to be reset by the motor itself. Once reset, it is held off by a compact 24V electromagnet. The motor is then free to operate as normal until the release of power to the brake.

**OPERATION**

NOTE: The following release and activate sequences are available as automatic Indexer routines in Copley’s CME 2 amplifier configuration software.

From power-on, the brake must be released before normal operation of the motor.

**Release:**

1. Apply power to the forcer and drive the thrust rod UP by applying sufficient force to overcome the braking action (70-80N)
2. Continue driving UP until the STOP on the thrust rod activates the BRAKE RELEASE. Activation can be detected by the controller when velocity=0 or there is no change in position.
3. Apply 24V to brake solenoid
4. Wait 100ms
5. The brake will now hold off and the forcer can operate as normal

**Activate:**

1. Remove 24V from the brake solenoid. The thrust rod will fall a very short distance before the brake activates
2. Wait 100ms
3. Disable the servo to remove power from the forcer

**SPECIFICATIONS**

**ENVIRONMENT**

Operating temperature: 0 to +40 °C  
Humidity (relative): 0 to 95% (Non-Condensing)

**BRAKE**

Holding Force: >200N  
Reset Force (using Motor) 50-70N

**ELECTRICAL**

Power requirement: 24Vd.c. +/- 10%  
Power Dissipation: 4W

**MECHANICAL DRAWING**

**SBA25**

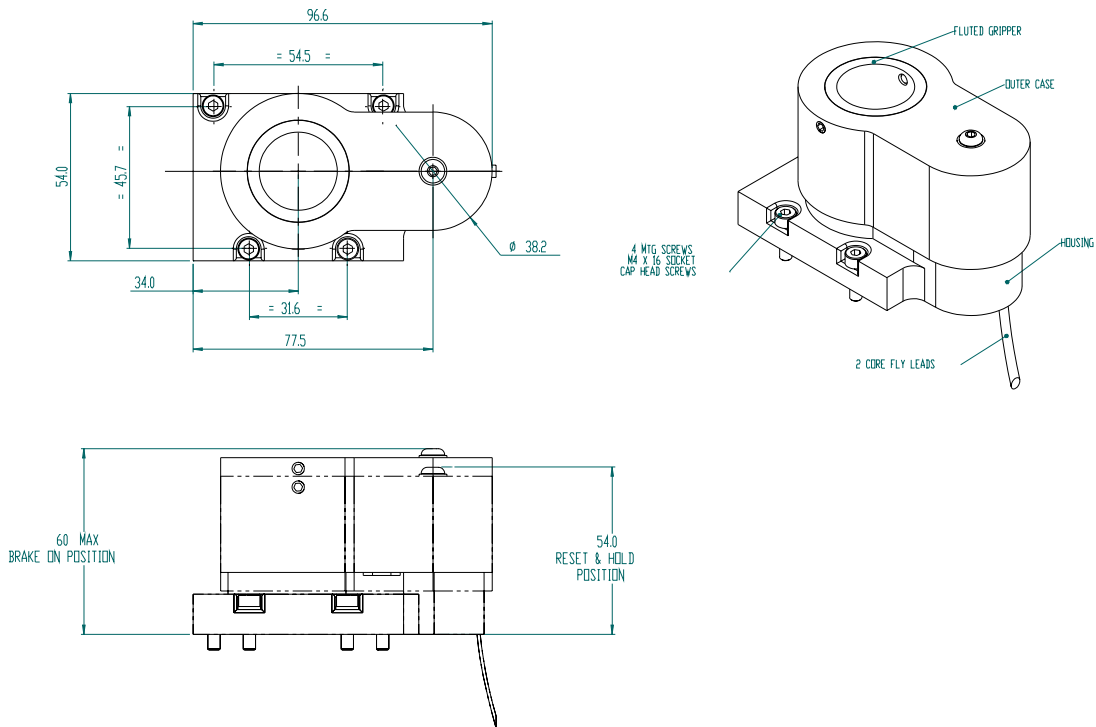

**SBR25**

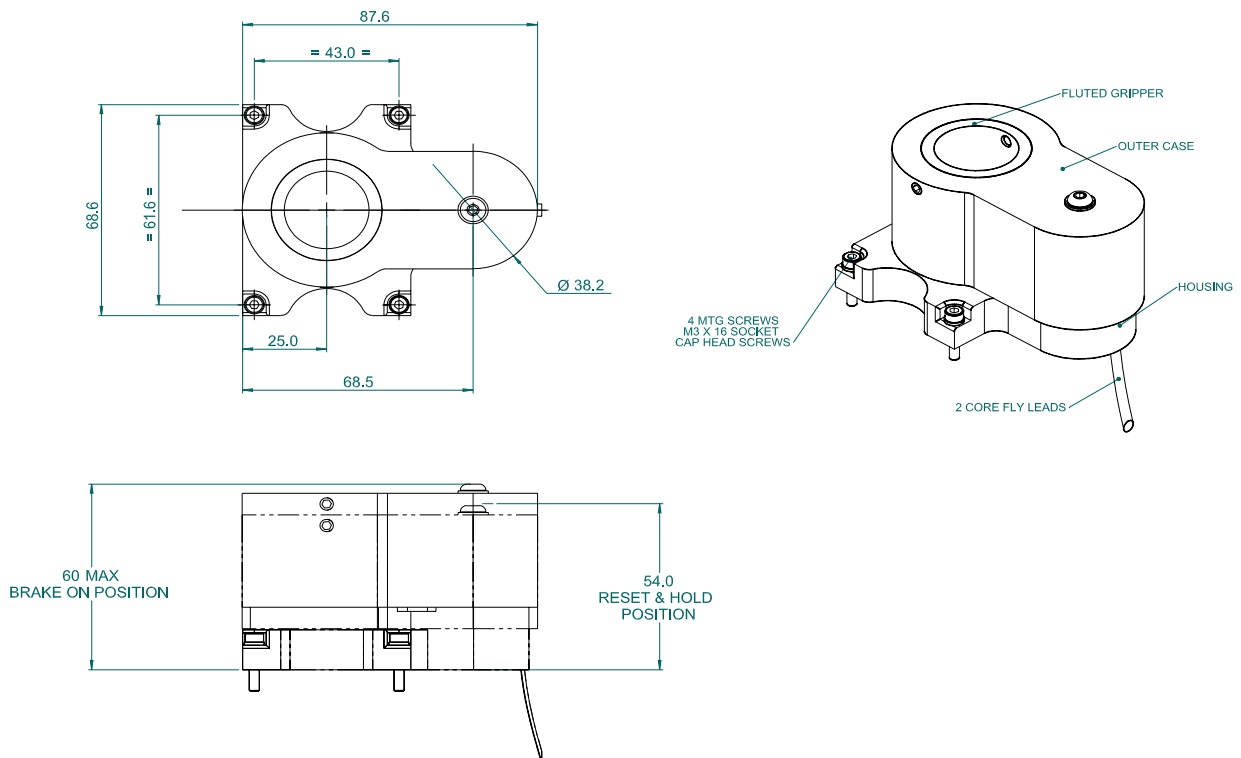

**ORDER CODES**

SBA25 for STA25  
SBR25 for XTR25