

RBE(H) Series Motors



The RBE series brushless motors feature high-energy product rare earth magnets resulting in high-continuous and peak torque ratings. Peak torque ranges from 3oz-in up to 145 lb-ft. Standard designs can operate at speeds up to 35,000 RPM.

These motors come in either housed (RBEH) or frameless (RBE) mechanical configurations. The Housed models come with stainless steel shafts and can include any combination of Hall sensors, encoder, or resolver as rotor position feedback devices.

The frameless configuration is supplied as two separate components (rotor and stator) and does not include a shaft, bearings, or endbells. Frameless motors are integrated directly with the load where the same bearings which support the load also support the motor. This configuration eliminates shaft, bearings, endbells, and couplings offering reduced volume, weight, complexity and also results in improved servo stiffness and quicker response. Frameless motors can include integral Hall sensors and additional position feedback devices such as encoders or resolvers would be added as separate components.

Advantages of Brushless Systems

Brushless systems offer distinct mechanical advantages over conventional systems. Placement of brushless windings into the outer stationary member and field magnets onto the inner rotating member allows significant reductions in rotor inertia and increases in acceleration. Winding heat can be transferred directly from the outer member into adjacent heat sinks. Cooling and efficiency are improved. Generally, brushless systems can provide extra performance while surviving a great variety of operating conditions and offer improved efficiency and heat dissipation. Kollmorgen's brushless motors are available frameless or housed and are easily matched with Kollmorgen servo amplifiers. As new technologies emerge, Kollmorgen will continue providing the very finest motion control system components.

Brushless Motor System Components

There are four basic components in a brushless motor drive system. They are the Armature, the Field, the Rotor Position Feedback and the Servo Amplifier.

The Armature

The armature is the wound member of the motor and consists of a three phase windings wound on a laminated iron core. The armature is the outer member and is stationary. It consists of low loss laminations bonded into a core which may have skewed winding slots. The core and slots are electrically insulated prior to inserting the winding. The winding consists of series of coils for each motor phase. Phase interconnections are made inside the winding, resulting in a "wye" or "delta" connection. With a three wire termination, there is no reason for the customer to require either a "wye" or "delta" internal connection. Three leads are typically brought out for connection to the amplifier.

The Field

The field assembly or rotor typically consists of permanent magnet poles bonded to a flux carrying yoke ring. The magnet material selected will depend upon the application. Available magnet materials include Samarium Cobalt and the new high energy Neodymium-Iron-Boron compounds. For high speed applications, a magnet retaining band can be placed around the rotor to insure mechanical integrity.

Rotor Position Feedback

High performance Brushless DC systems require rotor position feedback to the amplifier to perform the commutation function, which is required for the Brushless DC motor to rotate. Kollmorgen Brushless DC motor systems typically will include one of the following rotor feedback configurations: Hall sensors, encoder, or resolver. Hall sensors have the advantage that they are an integral part of the Armature and therefore do not require the customer to integrate a separate feedback device. For frameless motor applications which require a resolver or encoder, the customer will often need to add these as separate components in their system.

Servo Amplifier

The servo amplifier is required for a brushless motor to rotate. The servo amplifier acquires the rotor position feedback. This information is used to direct current into the appropriate windings of the Armature to develop torque. As the Rotor rotates, the Servo Amplifier uses the Rotor Position Feedback to redirect the current into a different winding phase, as necessary to continue to generate torque as the rotor rotates. The Servo amplifier will typically close an internal current loop. Optionally, the Servo amplifier can use the Rotor Position Feedback to control the velocity and / or the position of the motor.

Frameless vs. Housed

Kollmorgen brushless motors can be supplied either frameless or housed. A housed motor includes a shaft, bearings, and endbells along with any feedback devices, into an integral assembly. This is the classical motor configuration. The customer mounts the motor housing into the desired system and provides a mechanical coupling to the motor shaft. The coupling can be a direct shaft coupling, gearing, or belts / pulleys. In many applications, the customer mounts the load directly to the motor shaft with the motor bearings supporting the load. Frameless motors are supplied as two separate components; the Rotor (Field) and Stator (Armature). The Frameless motor does not include shaft, bearings, or endbells. Frameless motors are used in applications where the customer desires to minimize the size and weight of the motor and / or obtain the maximum dynamic performance. Since the load is often supported on its own bearing structure, the Frameless motor can be integrated directly onto the system / load shaft and be suspended on the same bearings as the load.

This eliminates the need for an additional shaft, bearings, endbells, and any coupling between the motor shaft and the load. An advantage of Frameless motors is that, since there is no coupling between the shaft and the load, torsional play between the motor and load is minimized resulting in improved dynamic performance. Another advantage of Frameless motors is that inertia matching between the motor and load, which is typically required for housed motor applications, is not a critical requirement for Frameless motor applications, since the motor and load are one inertial mass.

System Performance and Communication

Careful selection of system components optimizes brushless system performance. Kollmorgen offers brushless components for two kinds of brushless systems: six step (trapezoidal) and sinusoidal. Selection should be made based on the application and on the performance requirements. For most servo applications, a six step sequence is appropriate unless very smooth operation under load at slow speed is required. For such applications, sinusoidal amplifiers with selected brushless motors offer exceptionally smooth operation with low torque ripple.

Brushless motors are not commutated mechanically, such as with a commutator and brushes, but electronically based on rotor magnet position information. Kollmorgen six step amplifiers are designed to utilize Hall device position signals for commutation. Hall devices mounted onto the stator convey rotor magnet position to the amplifier. This position information is necessary for commutation which changes the direction of current flow in the proper motor windings at the proper time. The Hall devices are accurately aligned with the stator winding back EMF at the factory on all motors supplied with Hall devices.

The Hall device and Motor Phase Output diagram shows proper alignment of the three Hall device outputs with the three motor back EMF waveforms. Externally rotating the motor field generates a back EMF voltage in each phase, which is used to align the Hall sensor in the optimum position. Current supplied to each phase will correspond with the Hall device switching points.

External motor phase connections are labeled A, B, and C, “V-AB” refers to the back EMF voltage produced across leads A and B. “V-BC” and “V-CA” denote voltages produced across leads B and C and across C and A respectively. Corresponding Hall device outputs are labeled “H-AB”, “H-BC”, and “H-CA”.

Kollmorgen sinusoidal amplifiers are designed to utilize resolver or encoder / Hall sensor position information for commutation. This feedback may be customer supplied or factory supplied for housed brushless motors. Feedback selection will vary depending on the motor selected and the application. Motor selection for a sinusoidal system may require factory consultation to assure performance goals are met. Although six step commutation systems can provide torque with ripple as low as five or six percent, sinusoidal system torque ripple can approach values of one percent. Amplifiers for both system types are pulse width modulated.

RBE(H) Motor Series

INTRODUCTION

Motor Parameters

Motor parameters are listed on the individual data page for each motor. These parameters are dependent upon the size and shape of the model, but are independent of the winding used. Following is a brief description of the motor parameters.

Maximum Continuous Output Power at 25°C Ambient (HP Rated). This is the maximum continuous power output based on a 130°C temperature rise and a standard aluminum heat sink. (Standard heat sink size is listed just above the continuous performance curves). The maximum continuous power output can be increased if additional cooling is provided.

Speed at Rated Power (N Rated) is the speed at which the maximum continuous power is output.

Maximum Mechanical Speed (N Max) is the maximum speed which will not compromise rotor integrity.

Continuous Stall Torque at 25°C Ambient (Tc) is the maximum constant torque without rotation resulting in a steady state winding temperature rise of 130°C with the standard aluminum heat sink. The size of the standard heat sink is listed above the continuous performance curve for each RBE(H) series. The continuous stall torque can be increased if additional cooling is provided.

Peak Torque (Tp) is the maximum torque available from a given size of motor and is the torque the motor will provide when peak current **Ip** is provided. Peak torque is based on the maximum current density in the winding and is available for a maximum duration of 10 seconds.

Maximum Torque for Linear KT (Tsl) is the maximum torque for which **Kt** will be greater than 90 percent of **Kt** at low torque. As the torque increases above **Tsl**, **Kt** will drop below 90 percent of **Kt** at low torque and an incremental increase in current will yield a reduced increase in torque.

Motor Constant (Km) is the ratio of peak torque to the square root of power input at 25°C and at stall:

$$K_m = T_p / (P_p)^{.5}$$

This ratio is useful during the initial selection of a motor, because it indicates the ability of a motor to convert electrical power into torque. A common use of **Km** is to determine how much power a motor will dissipate in order to generate a certain amount of torque by using the following equation:

$$\text{Watts Dissipated} = \text{Torque}^2 / K_m^2$$

Thermal Resistance (Rth) is the ratio of winding temperature rise to average power losses continuously dissipated from the stator. Motor **Rth** values assume a standard aluminum heat sink which is specified above the continuous speed torque curve for each RBE(H) series. Customer supplied supplemental cooling can reduce the **Rth** value significantly resulting in increased continuous speed and torque operation.

Viscus Damping (Fi) is the torque loss due to rotational losses, mostly eddy current, which is proportional to speed. A lower **Fi** indicates less loss during high speed operation.

Maximum Static Friction (Tf) is the sum of the retarding torques at start-up or at stall within the motor. In a frameless brushless motor, retarding torques consist of magnetic frictional torque and cogging torque. Housed motor TF includes bearing and other retarding torques.

Maximum Cogging Torque (Tcog) is a torque disturbance based on the magnets in the field attraction to the teeth in the armature. Cogging torque is minimized in the motor design by strategic selection of slot / pole combinations and by skewing the laminations in the armature.

Number of Poles (P) is the number of magnetic poles in the field. The electrical cycles per revolution is equal to the number of poles to the number of poles divided by 2.

Winding Constants

There are six parameters, or winding constants, listed on the individual data page for each motor which vary according to the winding that is used in the model. The variations are governed by the number of wire turns per coil and the wire size. In some cases, values for more than one winding are listed. If none of the specified windings are suitable for a given application, additional windings are available by consulting the factory. Following is a brief description of each parameter.

Current at Continuous Torque (I_c) is the current required to obtain the nominal continuous torque from the motor with a nominal torque sensitivity **Kt**.

Current at Peak Torque (I_p) is the current required to obtain the nominal peak torque from the motor. At **I_p** , **Kt** will be reduced from the published **Kt** because **Kt** is reduced at torque above **Tsl**. **I_p** is based on the maximum current density in the winding and is available for a maximum duration of 10 seconds.

Torque Sensitivity (K_t) is the ratio of the developed torque to winding input current for the designated winding.

Back EMF Constant (K_b) is the ratio of voltage generated in the winding to the speed of the rotor. Since both **Kb** and **Kt** are determined by the same factors, **Kb** is directly proportional to **Kt**.

Motor Resistance (R_m) is the resistance measured between any two leads of the winding at 25°C.

Motor Inductance (L_m) is the winding inductance measured between any two leads of the winding. Factory tests are performed at 60 Hz with the rotor in place.

RBE(H) Motor Series

RBE(H) 00410 MOTOR SERIES PERFORMANCE DATA

Motor Parameters	Symbols	Units	00410	00411	00412	
Max Cont. Output Power at 25°C amb.	HP Rated	HP	0.019	0.027	0.032	
	P Rated	Watts	14	20	24	
Speed at Rated Power	N Rated	RPM	22400	15200	12550	
Max Mechanical Speed	N Max	RPM	35000	35000	35000	
Continuous Stall Torque at 25°C amb.	Tc	oz-in	1.54	2.93	4.13	
		N-m	0.0109	0.0207	0.0292	
Peak Torque	Tp	oz-in	3.49	7.13	11.0	
		N-m	0.025	0.050	0.08	
Max Torque for Linear KT	Tsl	oz-in	3.49	7.13	11.0	
		N-m	0.025	0.050	0.078	
Motor Constant	Tm	oz-in/ \sqrt{W}	0.65	1.09	1.46	
		N-m/ \sqrt{W}	0.005	0.008	0.010	
Thermal Resistance*	Rth	°C/Watt	8.00	7.11	6.64	
Viscous Damping	Fi	oz-in/RPM	1.80E-05	3.40E-05	5.00E-05	
		N-m/RPM	1.27E-07	2.40E-07	3.53E-07	
Max Static Friction	Tf	oz-in	0.60	0.88	1.15	
		N-m	0.0042	0.0062	0.0081	
Max Cogging Torque Peak to Peak	Tcog	oz-in	0.37	0.58	0.80	
		N-m	0.0026	0.0041	0.0060	
Frameless Motor	Inertia	Jmf	oz-in-sec ²	1.70E-05	2.70E-05	3.80E-05
			Kg-m ²	1.20E-07	1.91E-07	2.68E-07
Housed Motor	Weight	Wtf	oz	1.1	1.6	2.0
			Kg	3.1E-02	4.4E-02	5.7E-02
Housed Motor	Inertia	Jmh	oz-in-sec ²	1.70E-05	2.70E-05	3.80E-05
			Kg-m ²	1.20E-07	1.91E-07	2.68E-07
Housed Motor	Weight	Wth	oz	1.7	2.2	2.7
			Kg	4.8E-02	6.2E-02	7.7E-02
No. of poles	P		6	6	6	

Winding Constants	Symbols	Units	A	B	C	A	B	C	A	B	C
Current at Cont. Torque	Ic	Amps	2.27	1.79	3.09	2.31	1.80	3.24	2.99	2.72	1.99
Current at Peak Torque	Ip	Amps	4.33	3.43	6.13	4.86	3.86	6.88	6.88	6.13	4.33
Torque Sensitivity	Kt	oz-in/Amp	0.945	1.20	0.693	1.65	2.12	1.18	1.76	1.94	2.65
		N-m/Amp	0.00667	0.00845	0.00489	0.0116	0.0150	0.0083	0.0125	0.0137	0.0187
Back EMF constant	Kb	V/KRPM	0.699	0.885	0.513	1.22	1.57	0.870	1.30	1.44	1.96
Motor Resistance	Rm	Ohms	2.11	3.37	1.08	2.28	3.72	1.17	1.46	1.78	3.48
Motor Inductance	Lm	mH	0.18	0.29	0.096	0.26	0.43	0.13	0.20	0.24	0.45

*Rth assumes a housed motor mounted to a 3.25" x 3.25" x 0.25" aluminum heatsink or equivalent

Continuous Duty Capability for 130°C Rise — RBE - 00410 Series

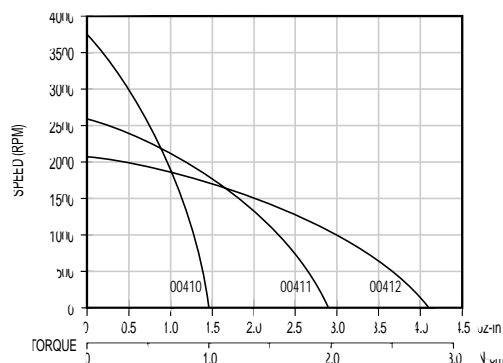

RBE(H) Motor Series

DIMENSIONS

RBE-0041X-X00

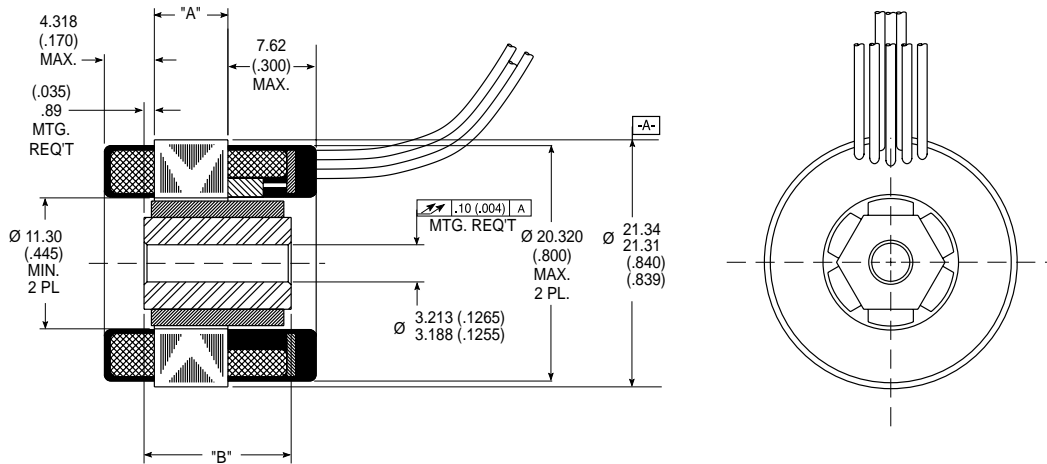

Dimensions in mm (inches).
Product designed in inches.
Metric conversions provided for reference only.

Notes:

- 1) For a C.W. rotation, as viewed from lead end, energize per excitation sequence table.
- 2) V-AB, V-BC and V-CA is back EMF of motor phases AB, BC and CA respectively, aligned with sensor output as shown for C.W. rotation only.
- 3) Sensors optimized for bi-directional rotation.

MODEL NUMBER	RBE-00410	RBE-00411	RBE-00412
"A" Dimension	6.35 (0.250)	12.70 (0.500)	19.05 (0.750)
"B" Dimension	12.70 (0.500)	19.05 (0.750)	25.40 (1.000)
Tolerance ± .010 on "A" Dimension.			

RBEH-0041X-X00

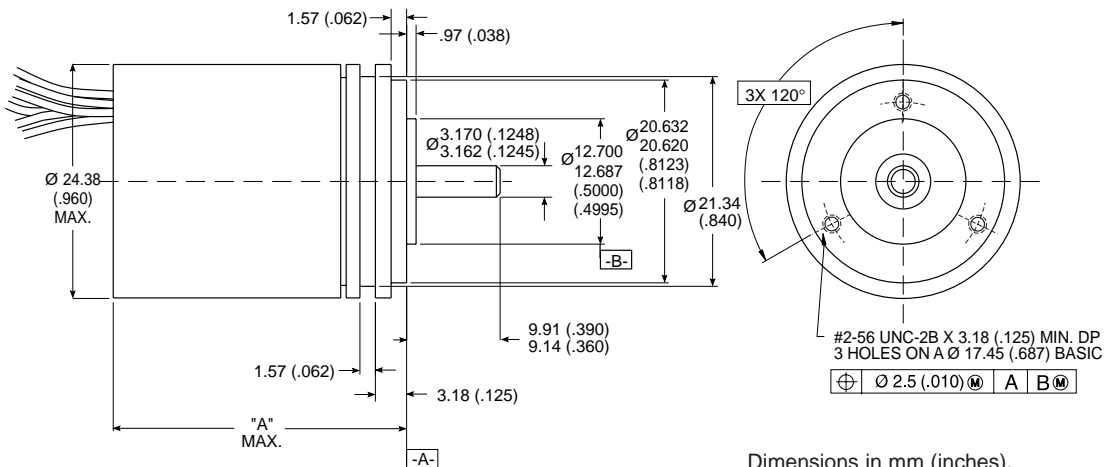

Dimensions in mm (inches).
Product designed in inches.
Metric conversions provided for reference only.

Notes:

- 1) Shaft end play: with a 1 lb reversing load, the axial displacement shall be .015-.152 (.0006-.006).
- 2) For a C.C.W. rotation, as viewed from pilot end, energize per excitation sequence table.
- 3) V-AB, V-BC and V-CA is back EMF of motor phases AB, BC and CA respectively, aligned with sensor output as shown for C.C.W. rotation only.

MODEL NUMBER	RBEH-00410	RBEH-00411	RBEH-00412
"A" Dimension	31.50 (1.240)	37.85 (1.490)	44.20 (1.740)

RBE/RBEH LEADWIRE

Motor Leads: #26 AWG type "ET" Teflon coated per MIL-W-16878, 3 leads, 152 (6.00) min lg. ea. 1-black, 1-white, 1-red.

Sensor Leads: #26 AWG type "ET" Teflon coated per MIL-W-16878, 5 leads, 152 (6.00) min lg. ea. 1-yellow, 1-green, 1-orange, 1-blue, 1-brown.

RBE(H) Motor Series

RBE(H) 00510 MOTOR SERIES PERFORMANCE DATA

Motor Parameters	Symbols	Units	00510	00511	00512	00513	
Max Cont. Output Power at 25°C amb.	HP Rated	HP	0.040	0.070	0.086	0.095	
	P Rated	Watts	29	52	64	71	
Speed at Rated Power	N Rated	RPM	20900	15700	13300	11700	
Max Mechanical Speed	N Max	RPM	28000	28000	28000	28000	
Continuous Stall Torque at 25°C amb.	Tc	oz-in	3.11	7.00	9.80	12.1	
		N-m	0.0219	0.0494	0.0692	0.0854	
Peak Torque	Tp	oz-in	7.05	15.8	24.4	32.1	
		N-m	0.050	0.111	0.17	0.23	
Max Torque for Linear KT	Tsl	oz-in	7.05	15.8	24.4	32.1	
		N-m	0.050	0.111	0.172	0.227	
Motor Constant	Tm	oz-in/ \sqrt{W}	1.00	1.91	2.53	3.03	
		N-m/ \sqrt{W}	0.00704	0.0135	0.0179	0.0214	
Thermal Resistance*	Rth	°C/Watt	6.23	5.20	4.75	4.51	
Viscous Damping	Fi	oz-in/RPM	4.00E-05	6.63E-05	9.32E-05	1.20E-04	
		N-m/RPM	2.83E-07	4.68E-07	6.58E-07	8.48E-07	
Max Static Friction	Tf	oz-in	0.61	0.80	1.00	1.20	
		N-m	0.0043	0.006	0.007	0.008	
Max Cogging Torque Peak to Peak	Tcog	oz-in	0.38	0.55	0.73	0.90	
		N-m	0.0027	0.0039	0.0051	0.0064	
Frameless Motor	Inertia	Jmf	oz-in-sec ²	4.50E-05	5.00E-05	5.60E-05	6.10E-05
			Kg-m ²	3.18E-07	3.53E-07	3.95E-07	4.31E-07
Weight	Wtf	oz	1.3	2.0	2.6	3.3	
		Kg	3.69E-02	5.55E-02	7.45E-02	9.36E-02	
Housed Motor	Inertia	Jmh	oz-in-sec ²	4.50E-05	5.00E-05	5.60E-05	6.10E-05
			Kg-m ²	3.18E-07	3.53E-07	3.95E-07	4.31E-07
Weight	Wth	oz	3.8	4.5	5.1	5.8	
		Kg	1.08E-01	1.26E-01	1.45E-01	1.64E-01	
No. of poles	P		6	6	6	6	

Winding Constants	Symbols	Units	A	B	C	A	B	C	A	B	C	A	B	C
Current at Cont. Torque	Ic	Amps	3.18	2.52	3.85	3.09	2.45	3.74	4.43	3.50	2.89	4.16	3.28	2.71
Current at Peak Torque	Ip	Amps	6.55	5.19	8.26	6.55	5.19	8.26	10.4	8.26	6.55	10.4	8.26	6.55
Torque Sensitivity	Kt	oz-in/Amp	1.17	1.47	0.966	2.53	3.19	2.09	2.44	3.09	3.74	3.20	4.05	4.90
		N-m/Amp	0.0083	0.0104	0.0068	0.0179	0.0225	0.0147	0.0172	0.0218	0.0264	0.0226	0.0286	0.0346
Back EMF constant	Kb	V/KRPM	0.865	1.09	0.715	1.87	2.36	1.54	1.81	2.29	2.77	2.36	2.99	3.62
Motor Resistance	Rm	Ohms	1.38	2.19	0.891	1.75	2.78	1.13	0.931	1.466	2.27	1.11	1.75	2.71
Motor Inductance	Lm	mH	0.22	0.34	0.15	0.38	0.60	0.26	0.25	0.40	0.59	0.34	0.55	0.80

*Rth assumes a housed motor mounted to a 3.25" x 3.25" x 0.25" aluminum heatsink or equivalent

Continuous Duty Capability for 130°C Rise — RBE - 00510 Series

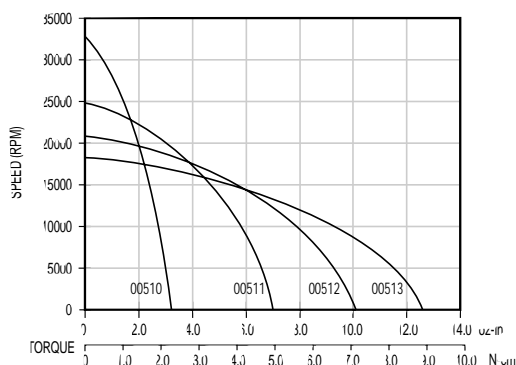

RBE(H) Motor Series

DIMENSIONS

RBE-0051X-X00

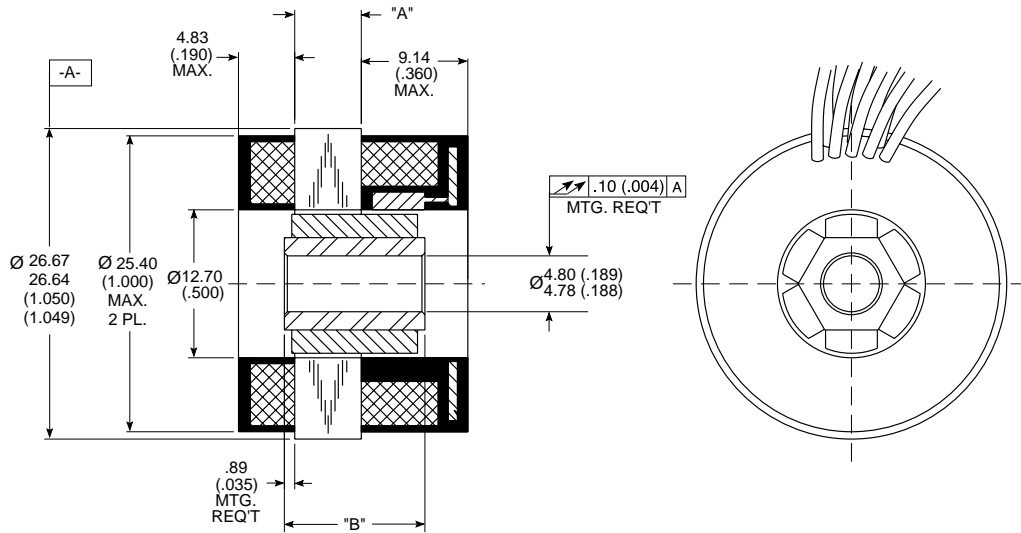

Dimensions in mm (inches).
Product designed in inches.
Metric conversions provided for reference only.

MODEL NUMBER	RBE-00510	RBE-00511	RBE-00512	RBE-00513
"A"	5.72	12.19	18.80	25.4
Dimension	(0.225)	(0.480)	(0.740)	(1.000)
"B"	12.07	18.54	25.15	31.75
Dimension	(0.475)	(0.730)	(0.990)	(1.250)

Tolerance $\pm .010$ on "A" Dimension.

Notes:

- 1) For a C.W. rotation, as viewed from lead end, energize per excitation sequence table.
- 2) V-AB, V-BC and V-CA is back EMF of motor phases AB, BC and CA respectively, aligned with sensor output as shown for C.W. rotation only.

RBEH-0051X-X00

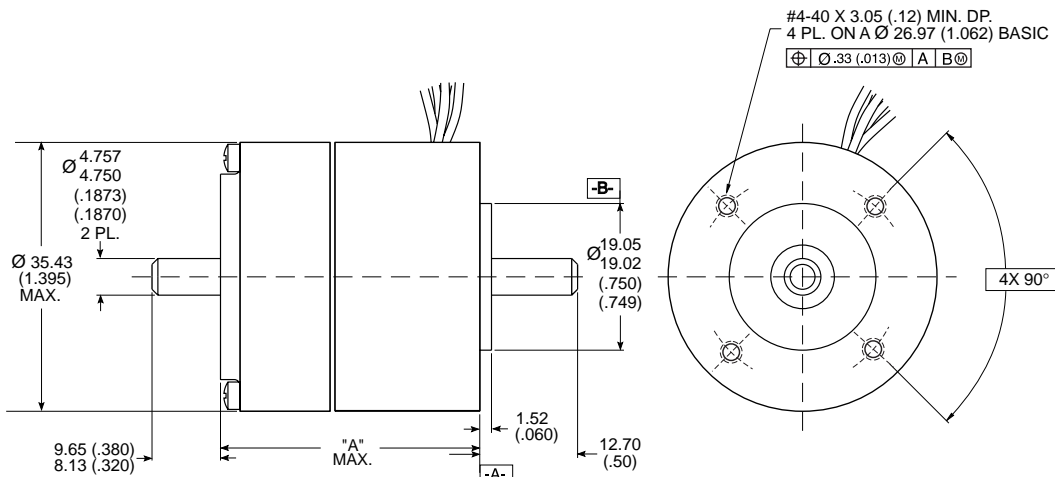

Dimensions in mm (inches).
Product designed in inches.
Metric conversions provided for reference only.

MODEL NUMBER	RBEH-00510	RBEH-00511	RBEH-00512	RBEH-00513
"A"	34.29	40.77	47.37	53.98
Dimension	(1.350)	(1.605)	(1.865)	(2.125)

Notes:

- 1) For a C.W. rotation, as viewed from lead end, energize per excitation sequence table.
- 2) V-AB, V-BC and V-CA is back EMF of motor phases AB, BC and CA respectively, aligned with sensor output as shown for C.W. rotation only.

RBE/RBEH LEADWIRE

Motor Leads: #26 AWG Teflon coated per MIL-W-22759/11, 3 leads, 152 (6.00) min lg. ea. 1-black, 1-white, 1-red.

Sensor Leads: #28 AWG type Teflon coated per MIL-W-22759/11, 5 leads, 152 (6.00) min lg. ea. 1-yellow, 1-green, 1-orange, 1-blue, 1-brown.

RBE(H) Motor Series

RBE(H) 00710 MOTOR SERIES PERFORMANCE DATA

Motor Parameters	Symbols	Units	00710	00711	00712	00713	00714	
Max Cont. Output Power at 25°C amb.	HP Rated	HP	0.0858	0.133	0.166	0.189	0.225	
	P Rated	Watts	64	99	124	141	168	
Speed at Rated Power	N Rated	RPM	17700	14110	12000	10800	9750	
Max Mechanical Speed	N Max	RPM	20000	20000	20000	20000	20000	
Continuous Stall Torque at 25°C amb.	Tc	oz-in	8.14	15.5	21.5	27.6	35.3	
		N-m	0.057	0.109	0.152	0.195	0.249	
Peak Torque	Tp	oz-in	22.7	43.8	63.3	84.5	114	
		N-m	0.160	0.310	0.447	0.597	0.802	
Max Torque for Linear KT	Tsl	oz-in	22.7	43.8	63.3	84.5	114	
		N-m	0.160	0.310	0.447	0.597	0.802	
Motor Constant	Km	oz-in/ \sqrt{W}	2.36	4.05	5.38	6.67	8.25	
		N-m/ \sqrt{W}	0.0166	0.029	0.038	0.047	0.058	
Thermal Resistance*	Rth	°C/Watt	5.90	4.91	4.47	4.19	3.94	
Viscous Damping	Fi	oz-in/RPM	4.40E-05	8.39E-05	1.20E-04	1.56E-04	2.00E-04	
		N-m/RPM	3.11E-07	5.93E-07	8.49E-07	1.11E-06	1.41E-06	
Max Static Friction	Tf	oz-in	0.90	1.54	2.12	2.70	3.40	
		N-m	0.0064	0.011	0.015	0.019	0.024	
Max Cogging Torque Peak to Peak	Tcog	oz-in	0.75	1.38	1.95	2.52	3.20	
		N-m	0.0053	0.0097	0.0137	0.0178	0.023	
Frameless Motor	Inertia	Jmf	oz-in-sec ²	1.30E-04	2.00E-04	2.80E-04	3.50E-04	4.40E-04
			Kg-m ²	9.18E-07	1.41E-06	1.98E-06	2.47E-06	3.11E-06
Housed Motor	Weight	Wtf	oz	2.8	4.4	5.8	7.2	8.9
			Kg	7.94E-02	1.24E-01	1.64E-01	2.04E-01	2.52E-01
Housed Motor	Inertia	Jmh	oz-in-sec ²	1.30E-04	2.00E-04	2.80E-04	3.60E-04	4.50E-04
			Kg-m ²	9.18E-07	1.41E-06	1.98E-06	2.54E-06	3.18E-06
Housed Motor	Weight	Wth	oz	7.8	9.3	11	12	14
			Kg	2.21E-01	2.65E-01	3.04E-01	3.44E-01	3.91E-01
No. of poles	P		6	6	6	6	6	

Winding Constants	Symbols	Units	A	B	C	A	B	C	A	B	C	A	B	C	A	B	C
Current at Cont. Torque	Ic	Amps	4.83	3.87	6.91	4.73	3.78	6.75	4.56	3.65	6.51	4.38	3.51	6.26	4.68	3.37	6.02
Current at Peak Torque	Ip	Amps	12.6	9.99	17.8	12.6	10.0	17.8	12.6	10.0	17.8	12.6	10.0	17.8	14.2	10.0	17.8
Torque Sensitivity	Kt	oz-in/Amp	1.87	2.34	1.31	3.60	4.50	2.52	5.19	6.49	3.63	6.92	8.65	4.85	8.26	11.5	6.43
		N-m/Amp	0.0132	0.0165	0.0092	0.0254	0.0318	0.0178	0.0367	0.0458	0.0257	0.0489	0.0611	0.0342	0.0584	0.0810	0.0454
Back EMF constant	Kb	V/KRPM	1.38	1.73	0.968	2.66	3.33	1.86	3.84	4.80	2.69	5.12	6.40	3.58	6.11	8.49	4.75
Motor Resistance	Rm	Ohms	0.629	0.991	0.311	0.790	1.24	0.390	0.933	1.47	0.461	1.08	1.70	0.533	1.00	1.97	0.618
Motor Inductance	Lm	mH	0.19	0.30	0.095	0.37	0.57	0.18	0.54	0.84	0.26	0.72	1.1	0.35	0.76	1.5	0.46

*Rth assumes a housed motor mounted to a 3.25" x 3.25" x 0.25" aluminum heatsink or equivalent

Continuous Duty Capability for 130°C Rise — RBE - 00710 Series

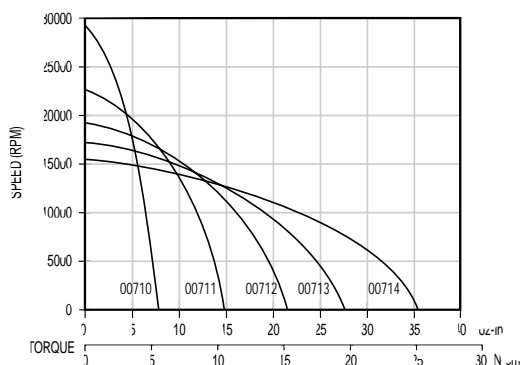

RBE(H) Motor Series

RBE(H) 01210 MOTOR SERIES PERFORMANCE DATA

Motor Parameters	Symbols	Units	01210	01211	01212	01213	01214	01215
Max Cont. Output Power at 25°C amb.	HP Rated	HP	0.142	0.204	0.243	0.272	0.290	0.310
	P Rated	Watts	106	152	181	203	216	231
Speed at Rated Power	N Rated	RPM	13800	9680	8100	7152	6230	5100
Max Mechanical Speed	N Max	RPM	18000	18000	18000	18000	18000	18000
Continuous Stall Torque at 25°C amb.	Tc	oz-in	16.4	31.6	43.5	54.8	66.2	90.4
		N-m	0.115	0.223	0.307	0.387	0.467	0.639
Peak Torque	Tp	oz-in	48.4	114	168	222	282	435
		N-m	0.342	0.806	1.18	1.57	1.99	3.07
Max Torque for Linear KT	Tsl	oz-in	48.4	114	168	222	282	435
		N-m	0.342	0.806	1.18	1.57	1.99	3.07
Motor Constant	Tm	oz-in/ \sqrt{W}	4.00	7.12	9.50	11.7	13.9	18.4
		N-m/ \sqrt{W}	0.028	0.050	0.067	0.083	0.098	0.130
Thermal Resistance*	Rth	°C/Watt	4.25	3.86	3.68	3.55	3.44	3.27
Viscous Damping	Fi	oz-in/RPM	1.30E-04	2.96E-04	4.46E-04	5.97E-04	7.78E-04	1.20E-03
		N-m/RPM	9.18E-07	2.09E-06	3.15E-06	4.22E-06	5.49E-06	8.48E-06
Max Static Friction	Tf	oz-in	1.70	2.13	2.53	2.92	3.40	4.50
		N-m	0.0120	0.015	0.018	0.021	0.024	0.032
Max Cogging Torque Peak to Peak	Tcog	oz-in	0.41	0.66	0.88	1.10	1.37	2.00
		N-m	0.0029	0.0046	0.0062	0.0078	0.0097	0.014
Frameless Motor	Inertia Jmf	oz-in-sec ²	7.30E-04	1.20E-03	1.70E-03	2.10E-03	2.70E-03	4.00E-03
		Kg-m ²	5.15E-06	8.47E-06	1.20E-05	1.48E-05	1.91E-05	2.82E-05
Housed Motor	Weight Wtf	oz	4.5	7.2	9.6	12.1	15.1	22.0
		Kg	1.26E-01	2.03E-01	2.74E-01	3.44E-01	4.28E-01	6.24E-01
Housed Motor	Inertia Jmh	oz-in-sec ²	7.60E-04	1.30E-03	1.80E-03	2.20E-03	2.80E-03	4.20E-03
		Kg-m ²	5.37E-06	9.18E-06	1.27E-05	1.55E-05	1.98E-05	2.97E-05
Housed Motor	Weight Wth	oz	11.3	14.2	16.8	19.5	22.6	30.0
		Kg	3.20E-01	4.02E-01	4.77E-01	5.52E-01	6.41E-01	8.50E-01
No. of poles	P		8	8	8	8	8	8

Winding Constants	Symbols	Units	A	B	C	A	B	C	A	B	C	A	B	C	A	B	C	A	B	C
Current at Cont. Torque	Ic	Amps	5.41	3.89	6.95	5.81	3.63	9.06	5.42	3.38	8.45	5.77	4.00	8.88	6.15	3.73	8.61	5.46	3.31	7.64
Current at Peak Torque	Ip	Amps	15.0	10.6	18.9	20.0	10.6	26.8	20.0	10.6	26.8	22.5	13.4	30.1	25.3	13.4	35.8	25.3	13.4	35.8
Torque Sensitivity	Kt	oz-in/Amp	3.34	4.64	2.60	5.80	9.30	3.72	8.49	13.6	5.45	10.0	14.5	6.50	11.3	18.7	8.08	17.4	28.7	12.4
		N-m/Amp	0.0236	0.0328	0.0183	0.0410	0.0657	0.0263	0.0600	0.0962	0.0385	0.0707	0.102	0.0459	0.0799	0.132	0.0571	0.123	0.203	0.0878
Back EMF constant	Kb	V/KRPM	2.47	3.43	1.92	4.29	6.88	2.75	6.28	10.1	4.03	7.41	10.7	4.81	8.36	13.8	5.97	12.9	21.2	9.19
Motor Resistance	Rm	Ohms	0.698	1.38	0.431	0.664	1.75	0.276	0.803	2.11	0.334	0.733	1.55	0.307	0.666	1.82	0.336	0.890	2.43	0.450
Motor Inductance	Lm	mH	0.280	0.54	0.17	0.32	0.83	0.13	0.44	1.1	0.18	0.47	0.97	0.20	0.48	1.3	0.25	0.71	1.9	0.36

*Rth assumes a housed motor mounted to a 4.0" x 3.75" x 0.25" aluminum heatsink or equivalent

Continuous Duty Capability for 130°C Rise — RBE - 01210 Series

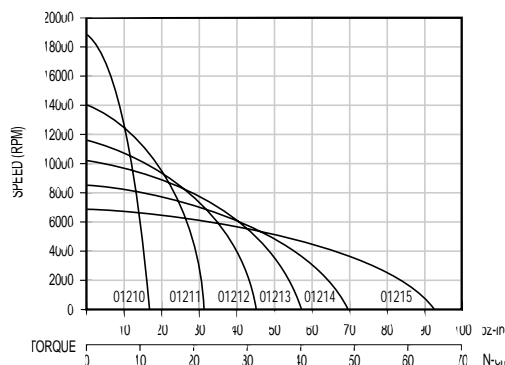

RBE(H) Motor Series

DIMENSIONS

RBE-0121X-X00

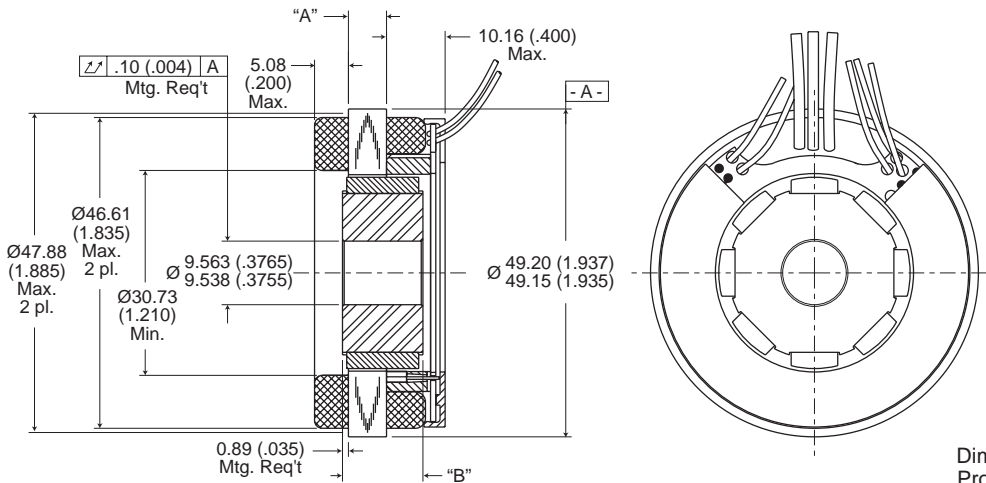

Dimensions in mm (inches).
Product designed in inches.
Metric conversions provided for reference only.

MODEL NUMBER	RBE-01210	RBE-01211	RBE-01212	RBE-01213	RBE-01214	RBE-01215
"A" Dimension	5.72 (0.225)	12.7 (0.500)	19.05 (0.750)	25.4 (1.000)	33.02 (1.300)	50.8 (2.000)
"B" Dimension	12.07 (0.475)	19.05 (0.750)	25.4 (1.000)	31.75 (1.250)	39.37 (1.550)	57.15 (2.250)

Tolerance $\pm .010$ on "A" Dimension.

Notes:

- 1) For a C.W. rotation, as viewed from lead end, energize per excitation sequence table.
- 2) V-AB, V-BC and V-CA is back EMF of motor phases AB, BC and CA respectively, aligned with sensor output as shown for C.W. rotation only.
- 3) Mounting surface is between $\varnothing 47.88$ (1.885) and $\varnothing 49.17$ (1.936) on both sides.

RBEH-0121X-X00

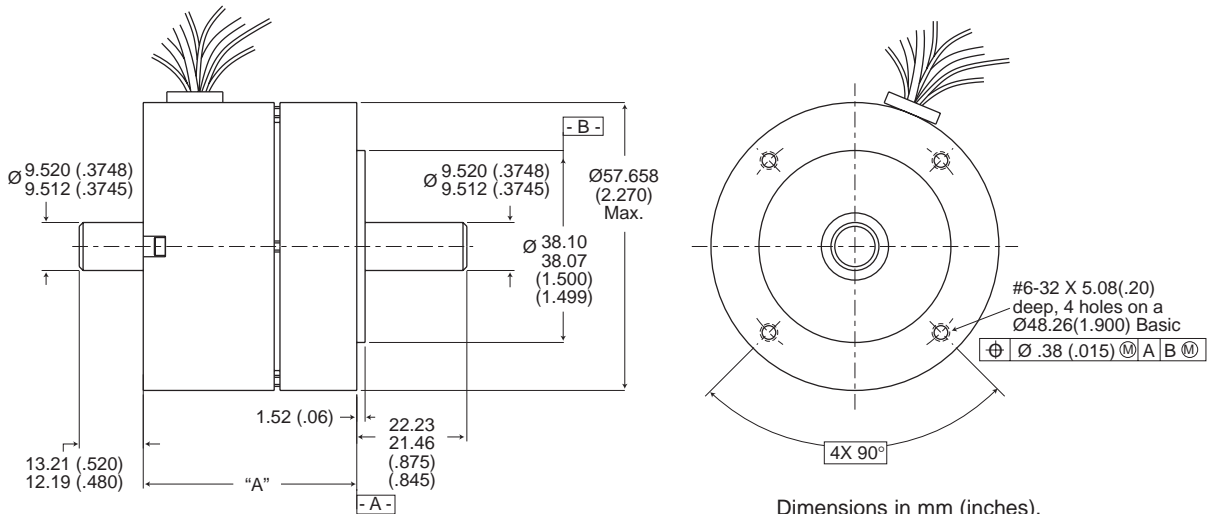

Dimensions in mm (inches).
Product designed in inches.
Metric conversions provided for reference only.

MODEL NUMBER	RBEH-01210	RBEH-01211	RBEH-01212	RBEH-01213	RBEH-01214	RBEH-01215
"A" Dimension	43.05 (1.695)	50.04 (1.970)	56.39 (2.220)	62.74 (2.470)	70.36 (2.770)	88.14 (3.470)

Notes:

- 1) Shaft end play: with a 9 lb reversing load, the axial displacement shall be .013-.15 (.0005-.006).
- 2) For a C.C.W. rotation, as viewed from pilot end, energize per excitation sequence table.
- 3) V-AB, V-BC and V-CA is back EMF of motor phases AB, BC and CA respectively, aligned with sensor output as shown for C.C.W. rotation only.

RBE/RBEH LEADWIRE

Motor Leads: #20 AWG Teflon coated per MIL-W-22759/11, 3 leads, 152 (6.00) min lg. ea. 1-black, 1-red, 1-white.

Sensor Leads: #26 AWG type "ET" Teflon coated per MIL-W-16878, 5 leads, 152 (6.00) min lg. ea. 1-blue, 1-brown, 1-green, 1-orange, 1-yellow.

RBE(H) Motor Series

RBE(H) 01510 MOTOR SERIES PERFORMANCE DATA

Motor Parameters	Symbols	Units	01510	01511	01512	01513	01514	01515	01516
Max Cont. Output Power at 25°C amb.	HP Rated	HP	0.127	0.176	0.210	0.240	0.264	0.284	0.307
	P Rated	Watts	95	131	157	179	197	212	229
Speed at Rated Power	N Rated	RPM	7450	5400	4550	4050	3570	3400	2970
Max Mechanical Speed	N Max	RPM	16500	16500	16500	16500	16500	16500	16500
Continuous Stall Torque at 25°C amb.	Tc	oz-in	27.4	54.3	71.9	91.3	114	127	154
		N-m	0.193	0.384	0.508	0.645	0.808	0.897	1.085
Peak Torque	Tp	oz-in	78.6	162	234	313	403	540	610
		N-m	0.555	1.15	1.66	2.21	2.85	3.81	4.31
Max Torque for Linear KT	Tsl	oz-in	78.6	162	234	313	403	540	610
		N-m	0.555	1.16	1.66	2.21	2.85	3.81	4.31
Motor Constant	Km	oz-in/√W	6.38	11.6	14.8	18.2	22.1	24.1	28.6
		N-m/√W	0.0451	0.0819	0.105	0.128	0.156	0.170	0.202
Thermal Resistance*	Rth	°C/Watt	4.10	3.55	3.30	3.13	2.95	2.85	2.72
Viscous Damping	Fi	oz-in/RPM	2.74E-04	1.05E-03	1.76E-03	2.47E-03	3.32E-03	3.88E-03	5.30E-03
		N-m/RPM	1.94E-06	7.43E-06	1.24E-05	1.74E-05	2.34E-05	2.74E-05	3.74E-05
Max Static Friction	Tf	oz-in	2.00	2.93	3.77	4.62	5.63	6.31	8.00
		N-m	0.0141	0.021	0.027	0.033	0.040	0.045	0.057
Max Cogging Torque Peak to Peak	Tcog	oz-in	0.950	1.22	1.47	1.71	2.01	2.21	2.70
		N-m	0.00671	0.00862	0.0104	0.0121	0.0142	0.0156	0.019
Frameless Motor	Jmf	oz-in-sec ²	2.10E-03	3.60E-03	4.90E-03	6.20E-03	7.70E-03	8.80E-03	1.14E-02
		Kg-m ²	1.48E-05	2.54E-05	3.46E-05	4.38E-05	5.44E-05	6.21E-05	8.05E-05
Housed Motor	Wth	oz	6.30	10.5	14.3	18.1	22.7	25.8	33.4
		Kg	1.79E-01	2.98E-01	4.06E-01	5.14E-01	6.44E-01	7.30E-01	9.47E-01
Inertia	Jmh	oz-in-sec ²	2.20E-03	3.70E-03	5.00E-03	6.30E-03	7.80E-03	8.90E-03	1.15E-02
		Kg-m ²	1.55E-05	2.61E-05	3.53E-05	4.45E-05	5.51E-05	6.28E-05	8.12E-05
Weight	Wtf	oz	19.0	23.5	27.5	31.6	36.4	39.7	47.8
		Kg	5.39E-01	6.65E-01	7.80E-01	8.95E-01	1.03E+00	1.13E+00	1.38E+00
No. of poles	P		12	12	12	12	12	12	12

Winding Constants	Symbols	Units	A			B			C			A			B			C			A			B			C		
Current at Cont. Torque	Ic	Amps	5.10	3.71	9.06	4.85	3.53	4.98	4.44	3.23	7.90	4.22	3.07	7.50	4.62	2.94	7.18	5.13	2.83	6.91	5.18	2.59	6.34						
Current at Peak Torque	Ip	Amps	14.0	9.89	25.0	14.0	9.89	16.7	14.0	9.89	25.0	14.0	9.89	25.0	15.7	9.89	25.0	21.0	9.89	25.0	19.8	9.89	25.0						
Torque Sensitivity	Kt	oz-in/Amp	6.78	7.92	3.24	11.6	16.2	11.5	17.0	23.4	9.56	22.7	31.2	12.8	26.0	40.9	16.7	26.0	47.2	19.3	31.2	62.3	25.5						
		N-m/Amp	0.0407	0.0559	0.0229	0.0833	0.115	0.0812	0.120	0.165	0.0675	0.160	0.220	0.0901	0.184	0.289	0.118	0.184	0.333	0.136	0.220	0.440	0.180						
Back EMF constant	Kb	V/KRPM	4.26	5.86	2.40	8.73	12.0	8.50	12.6	17.3	7.07	16.8	23.1	9.43	19.2	30.2	12.4	19.2	34.9	14.3	23.1	46.1	18.9						
Motor Resistance	Rm	Ohms	0.814	1.58	0.256	1.04	2.02	0.988	1.33	2.59	0.418	1.55	3.03	0.489	1.38	3.45	0.557	1.16	3.86	0.623	1.19	4.75	0.769						
Motor Inductance	Lm	mH	0.32	0.61	0.101	0.58	1.1	0.55	0.87	1.6	0.27	1.2	2.3	0.38	1.1	2.6	0.47	0.99	3.3	0.55	1.1	4.4	7.4						

*Rth assumes a housed motor mounted to a 4" x 3.25" x 0.25" aluminum heatsink or equivalent

Continuous Duty Capability for 130°C Rise — RBE - 01510 Series

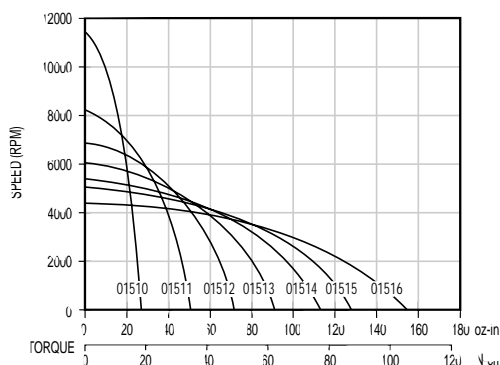

RBE(H) Motor Series

DIMENSIONS

RBE-0151X-X00

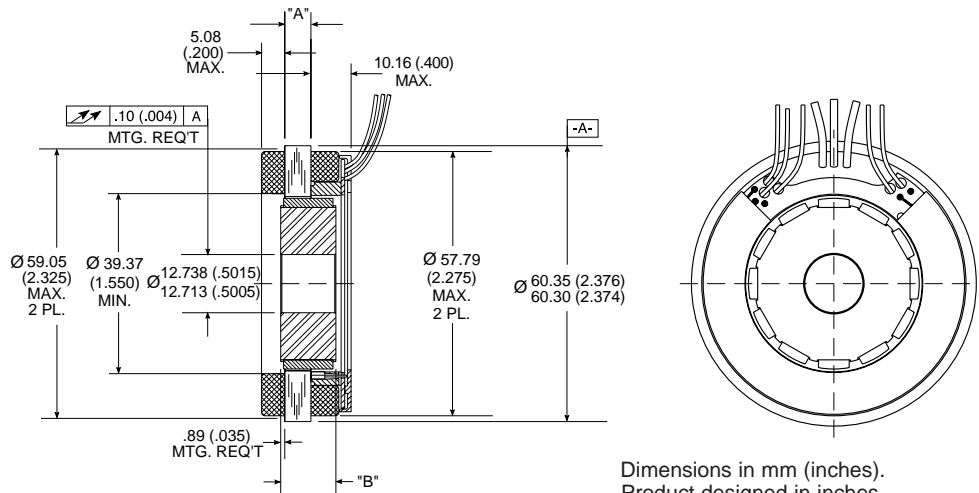

Dimensions in mm (inches).
Product designed in inches.

Metric conversions provided for reference only.

Notes:

- 1) For a C.W. rotation, as viewed from lead end, energize per excitation sequence table.
- 2) V-AB, V-BC and V-CA is back EMF of motor phases AB, BC and CA respectively, aligned with sensor output as shown for C.W. rotation only.
- 3) Mounting surface is between Ø 60.35 (2.376) and Ø 59.06 (2.325) on both sides.

MODEL NUMBER	RBE-01510	RBE-01511	RBE-01512	RBE-01513	RBE-01514	RBE-01515	RBE-01516
"A" Dimension	5.72 (0.225)	12.7 (0.500)	19.05 (0.750)	25.4 (1.000)	33.02 (1.300)	38.1 (1.500)	50.8 (2.000)
"B" Dimension	12.07 (0.475)	19.05 (0.750)	25.4 (1.000)	31.75 (1.250)	39.37 (1.550)	44.45 (1.750)	57.15 (2.250)

Tolerance ± .010 on "A" Dimension.

RBEH-0151X-X00

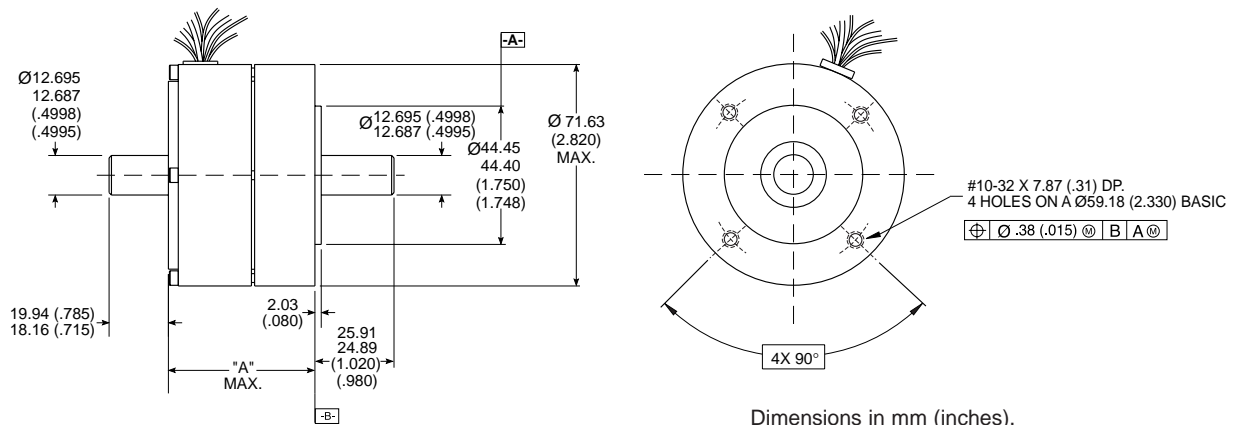

Dimensions in mm (inches).
Product designed in inches.

Metric conversions provided for reference only.

Notes:

- 1) Shaft end play: with a 11 lb reversing load, the axial displacement shall be .013-.15 (.0005-.006).
- 2) For a C.C.W. rotation, as viewed from pilot end, energize per excitation sequence table.
- 3) V-AB, V-BC and V-CA is back EMF of motor phases AB, BC and CA respectively, aligned with sensor output as shown for C.C.W. rotation only.

MODEL NUMBER	RBEH-01510	RBEH-01511	RBEH-01512	RBEH-01513	RBEH-01514	RBEH-01515	RBEH-01516
"A" Dimension	47.75 (1.880)	54.74 (2.155)	61.09 (2.405)	67.44 (2.655)	75.06 (2.955)	80.14 (3.155)	92.84 (3.655)

RBE/RBEH LEADWIRE

Motor Leads: #20 AWG Teflon coated per MIL-W-22759/11, 3 leads, 152 (6.00) min lg. ea. 1-black, 1-red, 1-white.

Sensor Leads: #26 AWG type "ET" Teflon coated per MIL-W-16878, 5 leads, 152 (6.00) min lg. ea. 1-blue, 1-brown, 1-green, 1-orange, 1-yellow.

RBE(H) Motor Series

RBE(H) 01810 MOTOR SERIES PERFORMANCE DATA

Motor Parameters	Symbols	Units	01810	01811	01812	01813	01814	01815
Max Cont. Output Power at 25°C amb.	HP Rated	HP	0.280	0.402	0.488	0.572	0.611	0.646
	P Rated	Watts	209	300	364	427	456	482
Speed at Rated Power	N Rated	RPM	7040	5250	4350	3850	3520	3230
Max Mechanical Speed	N Max	RPM	14000	14000	14000	14000	14000	14000
Continuous Stall Torque at 25°C amb.	Tc	oz-in	60.8	121	173	218	262	305
		N-m	0.429	0.856	1.22	1.54	1.85	2.16
Peak Torque	Tp	oz-in	216	430	654	871	1069	1297
		N-m	1.53	3.04	4.62	6.15	7.55	9.16
Max Torque for Linear KT	Tsl	oz-in	136	273	413	554	679	825
		N-m	0.96	1.93	2.92	3.91	4.80	5.83
Motor Constant	Km	oz-in/ \sqrt{W}	11.0	19.6	26.5	32.8	37.8	43.1
		N-m/ \sqrt{W}	0.077	0.139	0.187	0.231	0.267	0.304
Thermal Resistance*	Rth	°C/Watt	2.55	2.11	1.91	1.83	1.70	1.62
Viscous Damping	Fi	oz-in/RPM	9.00E-04	1.83E-03	2.71E-03	3.56E-03	4.39E-03	5.30E-03
		N-m/RPM	6.36E-06	1.29E-05	1.91E-05	2.52E-05	3.10E-05	3.74E-05
Max Static Friction	Tf	oz-in	3.10	4.49	5.81	7.09	8.33	9.70
		N-m	0.0219	0.032	0.041	0.050	0.059	0.069
Max Cogging Torque Peak to Peak	Tcog	oz-in	1.50	1.79	2.08	2.35	2.61	2.90
		N-m	0.0106	0.0127	0.0147	0.0166	0.0184	0.020
Frameless Motor	Jmf	oz-in-sec ²	5.10E-03	8.70E-03	1.22E-02	1.55E-02	1.88E-02	2.23E-02
		Kg-m ²	3.60E-05	6.14E-05	8.62E-05	1.09E-04	1.33E-04	1.57E-04
Housed Motor	Wtf	oz	12.0	19.8	27.2	34.5	41.4	49.1
		Kg	3.40E-01	5.61E-01	7.72E-01	9.77E-01	1.17E+00	1.39E+00
Inertia	Jmh	oz-in-sec ²	5.30E-03	8.80E-03	1.24E-02	1.58E-02	1.91E-02	2.27E-02
		Kg-m ²	3.74E-05	6.21E-05	8.76E-05	1.12E-04	1.35E-04	1.60E-04
Weight	Wth	oz	30.0	38.2	46.0	53.6	60.9	69.0
		Kg	8.50E-01	1.08E+00	1.30E+00	1.52E+00	1.73E+00	1.96E+00
No. of poles	P		12	12	12	12	12	12

Winding Constants	Symbols	Units	A	B	C	A	B	C	A	B	C	A	B	C	A	B	C	A	B	C
Current at Cont. Torque	Ic	Amps	5.28	2.85	7.39	5.24	2.82	7.34	4.91	2.64	6.87	5.87	3.49	10.2	5.73	3.41	9.93	5.51	3.28	9.54
Current at Peak Torque	Ip	Amps	21.3	10.0	30.2	21.3	10.0	30.2	21.3	10.0	30.2	26.9	14.2	40.3	26.9	14.2	40.3	26.9	14.2	40.3
Torque Sensitivity	Kt	oz-in/Amp	12.1	22.5	8.64	24.0	44.5	17.1	36.4	67.5	26.0	38.4	64.5	22.2	47.1	79.2	27.2	57.2	96.1	33.0
		N-m/Amp	0.0855	0.159	0.0610	0.170	0.315	0.121	0.257	0.477	0.184	0.271	0.456	0.157	0.333	0.559	0.192	0.404	0.679	0.233
Back EMF constant	Kb	V/KRPM	8.95	16.6	6.39	17.8	32.9	12.7	26.9	50.0	19.2	28.4	47.7	16.4	34.9	58.6	20.1	42.3	71.1	24.4
Motor Resistance	Rm	Ohms	1.22	4.16	0.615	1.49	5.10	0.753	1.88	6.42	0.949	1.38	3.79	0.458	1.55	4.28	0.518	1.76	4.85	0.588
Motor Inductance	Lm	mH	0.90	3.1	0.46	1.8	6.2	0.92	2.5	8.5	1.3	1.9	5.5	0.65	2.2	6.2	0.73	2.7	7.6	0.90

*Rth assumes a housed motor mounted to a 7" x 7.5" x 0.75" aluminum heatsink or equivalent

Continuous Duty Capability for 130°C Rise — RBE - 01810 Series

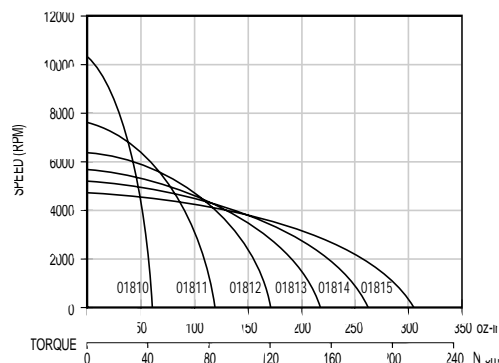

RBE(H) Motor Series

DIMENSIONS

RBE-0181X-X00

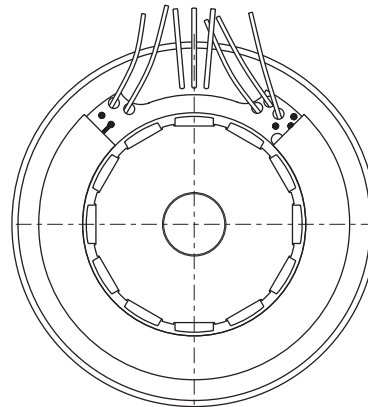
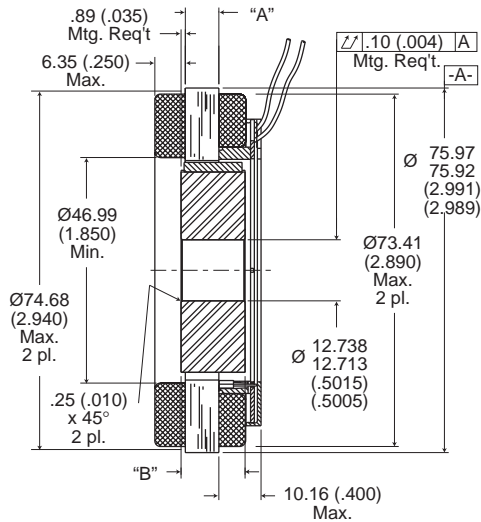

Dimensions in mm (inches).
Product designed in inches.
Metric conversions provided for reference only.

Notes:

- 1) For a C.W. rotation, as viewed from lead end, energize per excitation sequence table.
- 2) V-AB, V-BC and V-CA is back EMF of motor phases AB, BC and CA respectively, aligned with sensor output as shown for C.W. rotation only.
- 3) Mounting surface is between Ø 74.68 (2.940) and Ø 75.95 (2.990) on both sides.

MODEL NUMBER	RBE-01810	RBE-01811	RBE-01812	RBE-01813	RBE-01814	RBE-01815
"A" Dimension	6.99 (0.275)	15.24 (0.600)	23.11 (0.910)	30.73 (1.210)	38.10 (1.500)	46.23 (1.820)
"B" Dimension	13.34 (0.525)	21.59 (0.850)	29.46 (1.160)	37.08 (1.460)	44.45 (1.750)	52.58 (2.070)

Tolerance ± .010 on "A" Dimension.

RBEH-0181X-X00

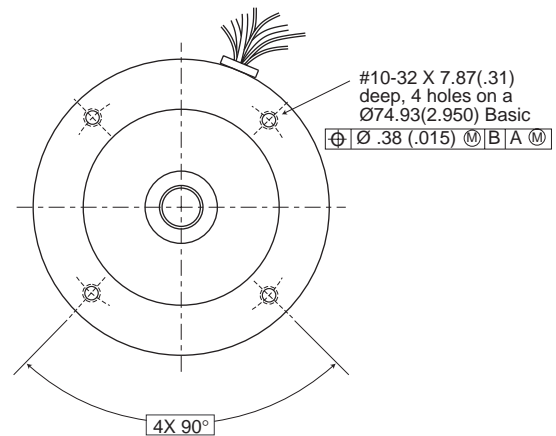
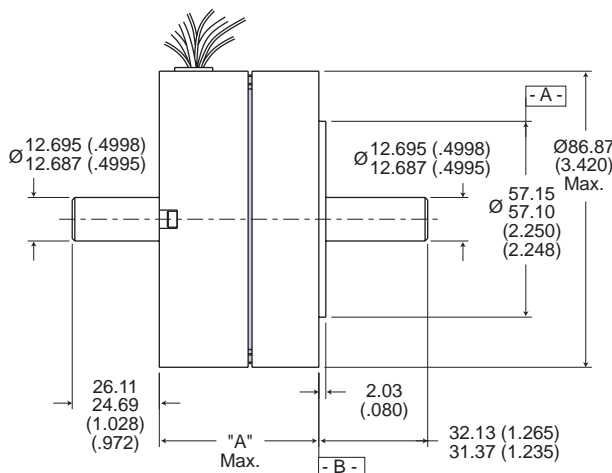

Dimensions in mm (inches).
Product designed in inches.
Metric conversions provided for reference only.

Notes:

- 1) Shaft end play: with a 9 lb reversing load, the axial displacement shall be .013-.15 (.0005-.006).
- 2) For a C.C.W. rotation, as viewed from pilot end, energize per excitation sequence table.
- 3) V-AB, V-BC and V-CA is back EMF of motor phases AB, BC and CA respectively, aligned with sensor output as shown for C.C.W. rotation only.

MODEL NUMBER	RBEH-01810	RBEH-01811	RBEH-01812	RBEH-01813	RBEH-01814	RBEH-01815
"A" Dimension	47.17 (1.857)	55.42 (2.182)	63.30 (2.492)	70.92 (2.792)	78.28 (3.082)	86.41 (3.402)

RBE/RBEH LEADWIRE

Motor Leads: #20 AWG Teflon coated per MIL-W-22759/11, 3 leads, 152 (6.00) min lg. ea. 1-black, 1-red, 1-white.

Sensor Leads: #26 AWG type "ET" Teflon coated per MIL-W-16878, 5 leads, 152 (6.00) min lg. ea. 1-blue, 1-brown, 1-green, 1-orange, 1-yellow.

RBE(H) Motor Series

RBE(H) 02110 MOTOR SERIES PERFORMANCE DATA

Motor Parameters	Symbols	Units	02110	02111	02112	02113	02114	02115
Max Cont. Output Power at 25°C amb.	HP Rated	HP	0.323	0.672	0.761	0.854	0.944	1.07
	P Rated	Watts	241	501	568	637	704	796
Speed at Rated Power	N Rated	RPM	5300	4242	3500	3050	2770	2650
Max Mechanical Speed	N Max	RPM	12000	12000	12000	12000	12000	12000
Continuous Stall Torque at 25°C amb.	Tc	lb-ft	0.703	1.23	1.77	2.20	2.69	3.20
		N-m	0.952	1.67	2.40	2.99	3.64	4.33
Peak Torque	Tp	lb-ft	1.87	3.37	5.10	6.80	8.27	10.2
		N-m	2.55	4.57	6.92	9.22	11.2	13.8
Max Torque for Linear KT	Tsl	lb-ft	1.26	2.56	3.75	5.00	6.37	7.49
		N-m	1.72	3.47	5.08	6.78	8.64	10.2
Motor Constant	Tm	lb-ft/ \sqrt{W}	0.102	0.175	0.243	0.293	0.345	0.394
		N-m/ \sqrt{W}	0.139	0.237	0.329	0.396	0.467	0.534
Thermal Resistance*	Rth	°C/Watt	1.70	1.60	1.50	1.40	1.30	1.20
Viscous Damping	Fi	lb-ft/RPM	1.04E-05	2.36E-05	3.59E-05	4.82E-05	6.06E-05	7.29E-05
		N-m/RPM	1.41E-05	3.19E-05	4.87E-05	6.54E-05	8.21E-05	9.88E-05
Max Static Friction	Tf	lb-ft	0.026	0.052	0.077	0.10	0.13	0.15
		N-m	0.035	0.071	0.104	0.136	0.171	0.203
Max Cogging Torque Peak to Peak	Tcog	lb-ft	0.016	0.039	0.061	0.082	0.104	0.125
		N-m	0.022	0.053	0.083	0.111	0.141	0.169
Frameless Motor	Inertia	Jmf	5.50E-05	9.70E-05	1.40E-04	1.74E-04	2.13E-04	2.66E-04
		Kg-m ²	7.46E-05	1.32E-04	1.90E-04	2.36E-04	2.89E-04	3.61E-04
Housed Motor	Weight	Wtf	1.29	2.21	3.07	3.94	4.80	5.66
		Kg	0.585	1.00	1.41	1.77	2.18	2.59
Housed Motor	Inertia	Jmh	5.60E-05	1.10E-04	1.41E-04	1.75E-03	2.14E-04	2.62E-04
		Kg-m ²	7.59E-05	1.49E-04	1.91E-04	2.37E-03	2.90E-04	3.55E-04
Housed Motor	Weight	Wth	2.00	3.22	4.37	5.51	6.66	7.80
		Kg	0.907	1.46	2.00	2.50	3.04	3.54
No. of poles	P		12	12	12	12	12	12

Winding Constants	Symbols	Units	A			B			C			A			B			C		
Current at Cont. Torque	Ic	Amps	6.34	2.53	10.6	5.71	2.27	9.74	5.42	2.17	9.03	5.07	2.03	8.46	8.13	3.95	3.05	8.67	3.98	1.77
Current at Peak Torque	Ip	Amps	25.3	10.0	40.2	25.3	10.0	40.2	25.3	10.0	40.2	25.3	10.0	40.3	40.3	20.1	15.9	45.3	20.1	10.6
Torque Sensitivity	Kt	lb-ft/Amp	0.115	0.287	0.0690	0.225	0.566	0.132	0.341	0.851	0.204	0.454	1.14	0.272	0.347	0.714	0.925	0.386	0.840	1.89
		N-m/Amp	0.156	0.390	0.0935	0.305	0.768	0.179	0.462	1.15	0.277	0.62	1.54	0.37	0.471	0.968	1.24	0.523	1.14	2.56
Back EMF constant	Kb	V/KRPM	16.3	40.8	9.80	31.9	80.4	18.7	48.4	121	29.1	64.5	161	38.6	49.2	101	130	54.8	119	268
Motor Resistance	Rm	Ohms	1.27	8.05	0.479	1.66	10.6	0.611	1.97	12.5	0.743	2.40	15.2	0.904	1.01	4.17	6.83	0.961	4.74	23.2
Motor Inductance	Lm	mH	1.7	10	0.60	3.2	20	1.1	5.1	32	1.8	6.2	39	2.2	2.8	12	20	3.0	14	72

*Rth assumes a housed motor mounted to a 7" x 7.5" x 0.75" aluminum heatsink or equivalent

Continuous Duty Capability for 130°C Rise — RBE - 02110 Series

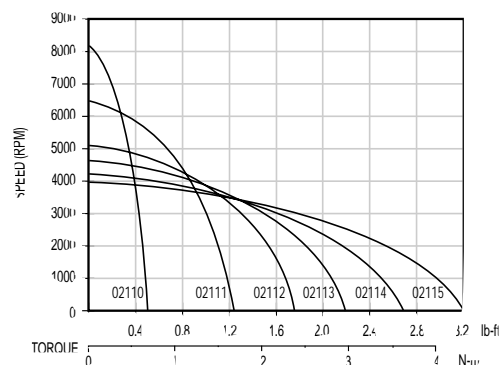

RBE(H) Motor Series

DIMENSIONS

RBE-0211X-X00

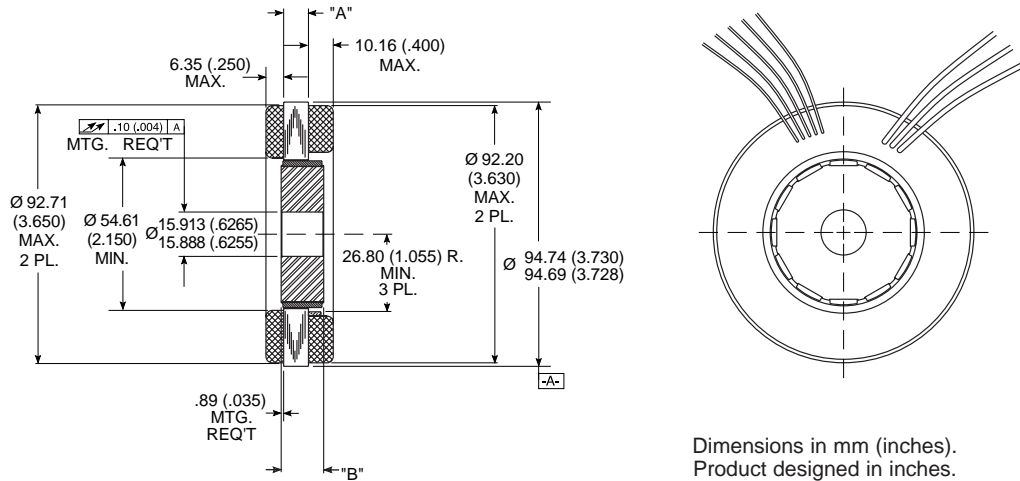

Dimensions in mm (inches).
Product designed in inches.
Metric conversions provided for reference only.

Notes:

- 1) For a C.W. rotation, as viewed from lead end, energize per excitation sequence table.
- 2) V-AB, V-BC and V-CA is back EMF of motor phases AB, BC and CA respectively, aligned with sensor output as shown for C.W. rotation only.
- 3) Mounting surface is between $\varnothing 92.71$ (3.650) and $\varnothing 94.72$ (3.729) on both sides.

MODEL NUMBER	RBE-02110	RBE-02111	RBE-02112	RBE-02113	RBE-02114	RBE-02115
"A"	8.89	19.05	28.58	38.1	47.63	57.15
Dimension	(0.350)	(0.750)	(1.125)	(1.500)	(1.875)	(2.250)
"B"	15.24	25.4	34.93	44.45	53.98	63.5
Dimension	(0.600)	(1.000)	(1.375)	(1.750)	(2.125)	(2.500)
Tolerance $\pm .010$ on "A" Dimension.						

RBEH-0211X-00

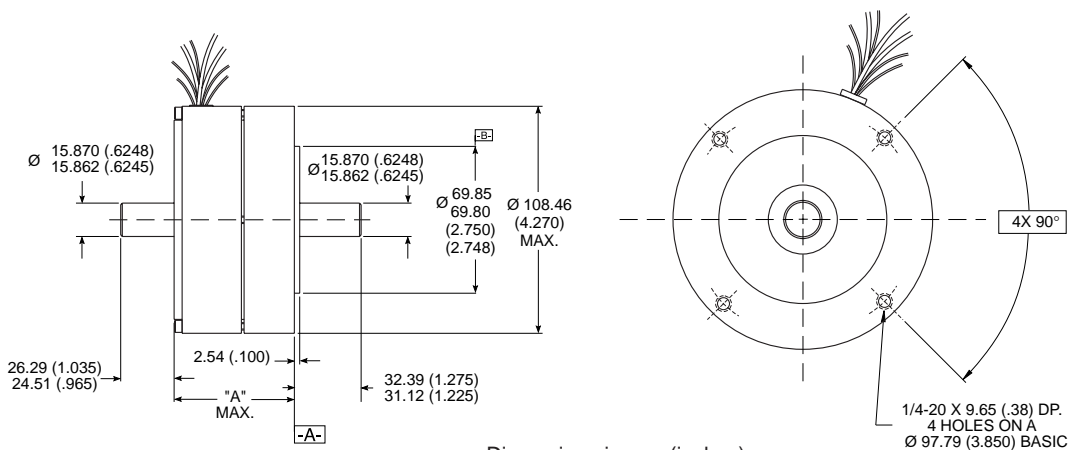

Dimensions in mm (inches).
Product designed in inches.
Metric conversions provided for reference only.

Notes:

- 1) Shaft end play: with a 18 lb reversing load, the axial displacement shall be .013-.13 (.0005-.005).
- 2) For a C.C.W. rotation, as viewed from pilot end, energize per excitation sequence table.
- 3) V-AB, V-BC and V-CA is back EMF of motor phases AB, BC and CA respectively, aligned with sensor output as shown for C.C.W. rotation only.

MODEL NUMBER	RBEH-02110	RBEH-02111	RBEH-02112	RBEH-02113	RBEH-02114	RBEH-02115
"A"	57.86	68.02	77.55	87.07	96.60	106.12
Dimension	(2.278)	(2.678)	(3.053)	(3.428)	(3.803)	(4.178)

RBE/RBEH LEADWIRE

Motor Leads: #18 AWG Teflon coated per MIL-W-22759/11, 3 leads, 152 (6.00) min lg. ea. 1-black, 1-red, 1-white.

Sensor Leads: #26 AWG type "ET" Teflon coated per MIL-W-16878, 5 leads, 152 (6.00) min lg. ea. 1-blue, 1-brown, 1-green, 1-orange, 1-yellow.

RBE(H) Motor Series

RBE(H) 03010 MOTOR SERIES PERFORMANCE DATA

Motor Parameters	Symbols	Units	03010	03011	03012	03013	03014	03015	03016		
Max Cont. Output Power at 25°C amb.	HP Rated	HP	0.863	1.12	1.32	1.48	1.49	1.60	1.61		
	P Rated	Watts	644	832	981	1107	1110	1190	1200		
Speed at Rated Power	N Rated	RPM	3000	2230	1830	1630	1460	1320	1200		
Max Mechanical Speed	N Max	RPM	8300	8300	8300	8300	8300	8300	8300		
Continuous Stall Torque at 25°C amb.	Tc	lb-ft	2.21	3.73	5.75	7.04	8.22	9.83	11.3		
		N-m	3.00	5.06	7.81	9.55	11.1	13.3	15.3		
Peak Torque	Tp	lb-ft	15.2	23.7	43.0	56.3	68.8	85.1	101		
		N-m	20.6	32.2	58.3	76.3	93.2	115	137		
Max Torque for Linear KT	Tsl	lb-ft	6.26	11.7	18.9	24.7	30.1	37.3	41.8		
		N-m	8.49	15.9	25.6	33.5	40.9	50.6	56.7		
Motor Constant	Km	lb-ft/ \sqrt{W}	0.308	0.482	0.707	0.846	0.958	1.13	1.27		
		N-m/ \sqrt{W}	0.418	0.653	0.958	1.15	1.30	1.53	1.73		
Thermal Resistance*	Rth	°C/Watt	1.55	1.32	1.20	1.14	1.07	1.03	1.00		
Viscous Damping	Fi	lb-ft/RPM	5.06E-05	8.44E-05	1.21E-04	1.55E-04	1.86E-04	2.26E-04	2.58E-04		
		N-m/RPM	6.86E-05	1.14E-04	1.64E-04	2.10E-04	2.52E-04	3.06E-04	3.50E-04		
Max Static Friction	Tf	lb-ft	0.0938	0.171	0.255	0.332	0.401	0.493	0.566		
		N-m	0.127	0.231	0.345	0.450	0.544	0.668	0.767		
Max Cogging Torque Peak to Peak	Tcog	lb-ft	0.0521	0.103	0.159	0.210	0.257	0.317	0.366		
		N-m	0.0706	0.140	0.216	0.285	0.348	0.430	0.496		
Frameless Motor	Inertia	Jmf	oz-in-sec ²	2.03E-04	3.54E-04	5.16E-04	6.67E-04	8.02E-04	9.84E-04	1.13E-03	
			Kg-m ²	2.75E-04	4.80E-04	7.00E-04	9.04E-04	1.09E-03	1.33E-03	1.53E-03	
Housed Motor	Weight	Wtf	lb	3.25	5.36	7.68	9.79	11.7	14.2	16.2	
			Kg	1.41	2.43	3.48	4.44	5.31	6.45	7.37	
Housed Motor	Inertia	Jmh	oz-in-sec ²	3.33E-04	5.78E-04	8.44E-04	1.09E-03	1.31E-03	1.61E-03	1.84E-03	
			Kg-m ²	4.52E-04	7.84E-04	1.14E-03	1.48E-03	1.78E-03	2.18E-03	2.49E-03	
No. of poles	P	Weight	Wth	lb	7.56	10.1	13.0	15.5	17.9	20.9	23.4
			Kg	3.43	4.60	5.90	7.05	8.10	9.50	10.6	

Winding Constants	Symbols	Units	A			B			C			A			B			C			A			B			C		
Current at Cont. Torque	Ic	Amps	7.58	5.87	3.60	7.30	5.62	3.49	6.98	5.38	3.34	6.54	5.03	3.12	6.26	4.82	2.99	6.05	4.66	2.89	5.84	4.19	2.82						
Current at Peak Torque	Ip	Amps	60.5	40.3	24.3	53.9	35.9	22.6	60.5	40.3	25.4	60.5	40.3	25.4	60.5	40.3	25.4	60.5	40.3	25.3	60.5	72.0	25.3						
Torque Sensitivity	Kt	lb-ft/Amp	0.304	0.392	0.640	0.535	0.695	1.12	0.862	1.12	1.80	1.13	1.47	2.37	1.38	1.79	2.88	1.72	2.23	3.60	2.03	1.45	4.21						
		N-m/Amp	0.412	0.531	0.868	0.725	0.942	1.52	1.17	1.52	2.45	1.53	1.99	3.21	1.87	2.43	3.92	2.33	3.03	4.88	2.75	1.96	5.70						
Back EMF constant	Kb	V/KRPM	43.1	55.6	90.9	75.9	99	159	122	159	256	160	208	336	196	255	410	244	317	511	288	206	597						
Motor Resistance	Rm	Ohms	0.974	1.63	4.23	1.23	2.09	5.33	1.49	2.51	6.43	1.78	3.00	7.70	2.07	3.48	8.95	2.30	3.87	9.94	2.54	1.32	10.9						
Motor Inductance	Lm	mH	1.9	3.2	8.4	3.3	5.6	14	4.8	8.1	21	6.2	10	27	7.6	13	33	8.9	15	39	11	5.6	47						

*Rth assumes a housed motor mounted to a 7.5" x 7" x 0.375" aluminum heatsink or equivalent

Continuous Duty Capability for 130°C Rise — RBE - 03010 Series

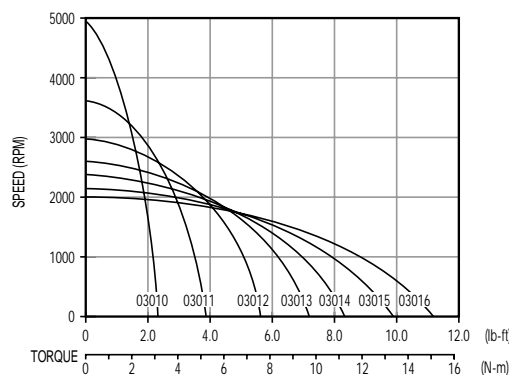

RBE(H) Motor Series

RBE(H) 04510 MOTOR SERIES PERFORMANCE DATA

Motor Parameters	Symbols	Units	04510	04511	04512
Max Cont. Output Power at 25°C amb.	HP Rated	HP	2.10	3.03	3.54
	P Rated	Watts	1568	2262	2640
Speed at Rated Power	N Rated	RPM	3240	2210	2100
Max Mechanical Speed	N Max	RPM	6000	6000	6000
Continuous Stall Torque at 25°C amb.	Tc	lb-ft	4.83	10.6	15.9
		N-m	6.55	14.4	21.5
Peak Torque	Tp	lb-ft	20.5	46.8	72.5
		N-m	27.7	63.5	98.3
Max Torque for Linear KT	Tsl	oz-in	9.83	24.9	41.1
		N-m	0.069	0.176	0.290
Motor Constant	Km	lb-ft/ \sqrt{W}	0.489	0.99	1.42
		N-m/ \sqrt{W}	0.662	1.34	1.93
Thermal Resistance*	Rth	°C/Watt	0.83	0.71	0.65
Viscous Damping	Fi	lb-ft/RPM	1.60E-04	2.90E-04	4.20E-04
		N-m/RPM	2.17E-04	3.93E-04	5.69E-04
Max Static Friction	Tf	lb-ft	0.16	0.35	0.53
		N-m	0.217	0.468	0.719
Max Cogging Torque Peak to Peak	Tcog	lb-ft	0.07	0.10	0.13
		N-m	0.096	0.133	0.169
Frameless Motor	Inertia	Jmf	1.20E-03	2.30E-03	3.40E-03
		Kg-m ²	1.63E-03	3.12E-03	4.61E-03
Weight	Wtf	lb	6.0	10.5	15.0
		Kg	2.72	4.76	6.80
Housed Motor	Inertia	Jmh	1.60E-03	2.35E-03	3.40E-03
		Kg-m ²	2.17E-03	3.19E-03	4.61E-03
Weight	Wth	lb	14.0	18.5	23.0
		Kg	6.35	8.39	10.4
No. of poles	P		12	12	12

Winding Constants	Symbols	Units	A	B	C	A	B	C	A	B	C
Current at Cont. Torque	Ic	Amps	11.7	6.20	17.1	11.3	10.3	16.4	19.5	15.9	10.9
Current at Peak Torque	Ip	Amps	80.8	48.0	114	80.8	72.0	114	144	114	80.8
Torque Sensitivity	Kt	lb-ft/Amp	0.425	0.805	0.292	0.973	1.06	0.669	0.844	1.03	1.50
		N-m/Amp	0.576	1.09	0.396	1.32	1.44	0.907	1.14	1.40	2.03
Back EMF constant	Kb	V/KRPM	60.4	114	41.5	138	151	95.0	120	146	213
Motor Resistance	Rm	Ohms	0.757	2.78	0.366	0.964	1.18	0.465	0.352	0.542	1.12
Motor Inductance	Lm	mH	3.6	13	1.7	4.6	5.4	2.2	2.2	3.3	7.0

*Rth assumes a housed motor mounted to a 13" x 12.5" x 0.5" aluminum heatsink or equivalent

Continuous Duty Capability for 130°C Rise — RBE - 04510 Series

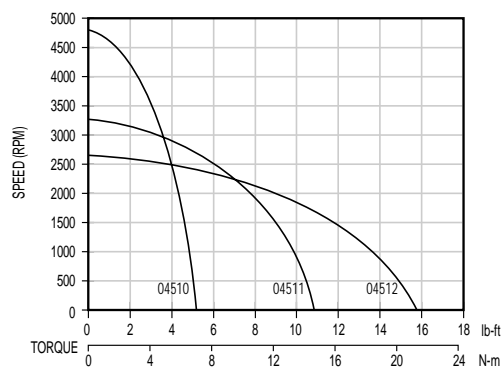

RBE(H) Motor Series

DIMENSIONS

RBE-0451X-X00

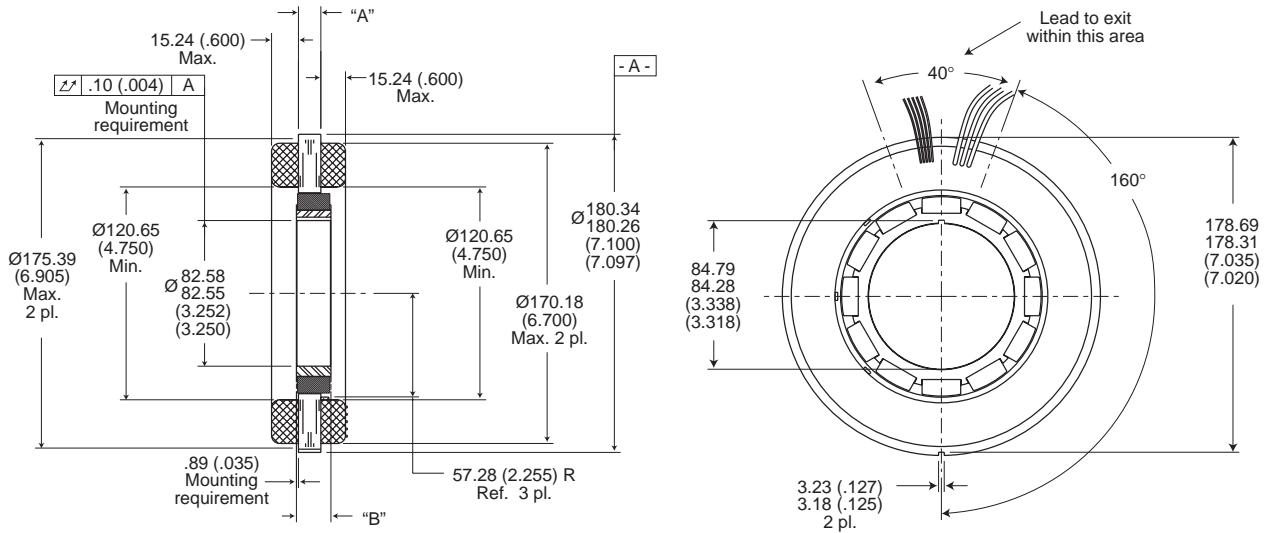

Dimensions in mm (inches).
Product designed in inches.
Metric conversions provided for reference only.

Notes:

- 2) For a C.W. rotation, as viewed from lead end, energize per excitation sequence table.
- 4) V-AB, V-BC and V-CA is back EMF of motor phases AB, BC and CA respectively, aligned with sensor output as shown for C.W. rotation only.
- 5) Mounting surface is between Ø 175.39 (6.905) and Ø 180.31 (7.099) on both sides.

MODEL NUMBER	RBE-04510	RBE-04511	RBE-04512
"A"	12.7	29.21	45.72
Dimension	(0.500)	(1.150)	(1.800)
"B"	19.56	36.07	52.58
Dimension	(0.770)	(1.420)	(2.070)
Tolerance ± .010 on "A" Dimension.			

RBEH-0451X-X00

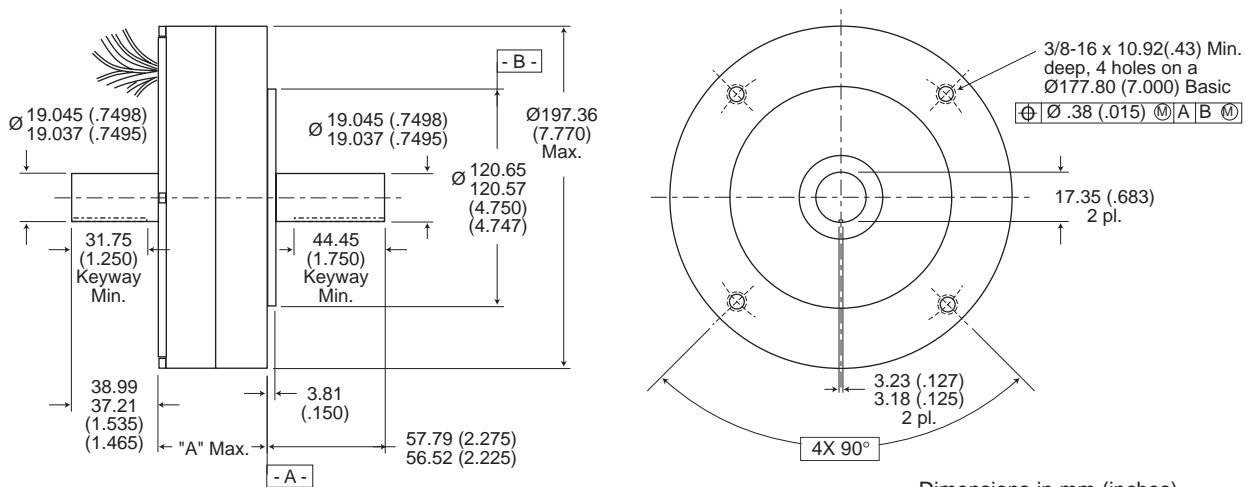

Dimensions in mm (inches).
Product designed in inches.
Metric conversions provided for reference only.

Notes:

- 1) Shaft end play: with a 34 lb reversing load, the axial displacement shall be .013-.15 (.0005-.006).
- 2) For a C.C.W. rotation, as viewed from pilot end, energize per excitation sequence table.
- 3) V-AB, V-BC and V-CA is back EMF of motor phases AB, BC and CA respectively, aligned with sensor output as shown for C.C.W. rotation only.

MODEL NUMBER	RBEH-04510	RBEH-04511	RBEH-04512
"A"	76.45	92.96	109.47
Dimension	(3.010)	(3.660)	(4.310)

RBE/RBEH LEADWIRE

Motor Leads: #14 AWG type Teflon coated per MIL-W-22759/11, 3 leads, 152 (6.00) min. long each 1-black, 1-red, 1-white.

Sensor Leads: #26 AWG type "ET" Teflon coated per MIL-W-16878, 5 leads, 152 (6.00) min long each 1-blue, 1-brown, 1-green, 1-orange, 1-yellow.

RBE(H) Motor Series

RBE(H) 06210 MOTOR SERIES PERFORMANCE DATA

Motor Parameters	Symbols	Units	06210	06211	06212
Max Cont. Output Power at 25°C amb.	HP Rated	HP	3.06	4.31	4.95
	P Rated	Watts	2286	3212	3690
Speed at Rated Power	N Rated	RPM	2650	1750	1390
Max Mechanical Speed	N Max	RPM	4500	4500	4500
Continuous Stall Torque at 25°C amb.	Tc	lb-ft	8.67	19.0	28.4
		N-m	11.8	25.8	38.4
Peak Torque	Tp	lb-ft	41.9	94.6	145
		N-m	56.8	128	197
Max Torque for Linear KT	Tsl	lb-ft	20.2	45.5	97
		N-m	27.4	61.7	131
Motor Constant	Km	lb-ft/ \sqrt{W}	0.80	1.64	2.37
		N-m/ \sqrt{W}	1.09	2.23	3.22
Thermal Resistance*	Rth	°C/Watt	0.70	0.62	0.58
Viscous Damping	Fi	lb-ft/RPM	1.50E-04	5.75E-04	1.00E-03
		N-m/RPM	2.03E-04	7.80E-04	1.36E-03
Max Static Friction	Tf	lb-ft	0.24	0.47	0.70
		N-m	0.325	0.637	0.949
Max Cogging Torque Peak to Peak	Tcog	lb-ft	0.13	0.18	0.23
		N-m	0.176	0.244	0.312
Frameless Motor	Inertia	Jmf	3.60E-03	7.30E-03	1.11E-02
		Kg-m ²	4.88E-03	9.90E-03	1.50E-02
Weight	Wtf	lb	10.8	18.2	25.6
		Kg	4.90	8.26	11.6
Housed Motor	Inertia	Jmh	3.70E-03	1.15E-02	1.20E-02
		Kg-m ²	5.02E-03	1.56E-02	1.63E-02
Weight	Wth	lb	22.3	29.8	37.3
		Kg	10.1	13.5	16.9
No. of poles	P		12	12	12

Winding Constants	Symbols	Units	A	B	C	A	B	C	A	B	C
Current at Cont. Torque	Ic	Amps	17.5	8.0	12.4	16.9	7.8	12.0	18.5	29.6	11.7
Current at Peak Torque	Ip	Amps	162	85.7	114	162	85.7	114	182	289	114
Torque Sensitivity	Kt	lb-ft/Amp	0.510	1.11	0.718	1.15	2.51	1.62	1.57	0.981	2.49
		N-m/Amp	0.691	1.51	0.973	1.56	3.40	2.19	2.13	1.33	3.37
Back EMF constant	Kb	V/KRPM	72.4	158	102	163	356	230	223	139	353
Motor Resistance	Rm	Ohms	0.405	1.93	0.804	0.489	2.33	0.970	0.438	0.172	1.10
Motor Inductance	Lm	mH	2.1	9.9	4.1	3.6	17	7.2	4.0	1.6	10

*Rth assumes a housed motor mounted to a 13" x 12.5" x 0.5" aluminum heatsink or equivalent

Continuous Duty Capability for 130°C Rise — RBE - 06210 Series

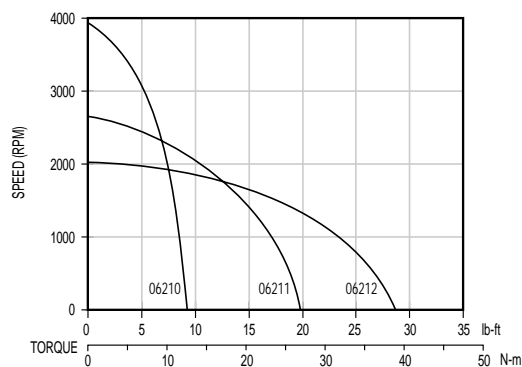

RBE(H) Motor Series

DIMENSIONS

RBE-0621X-X00

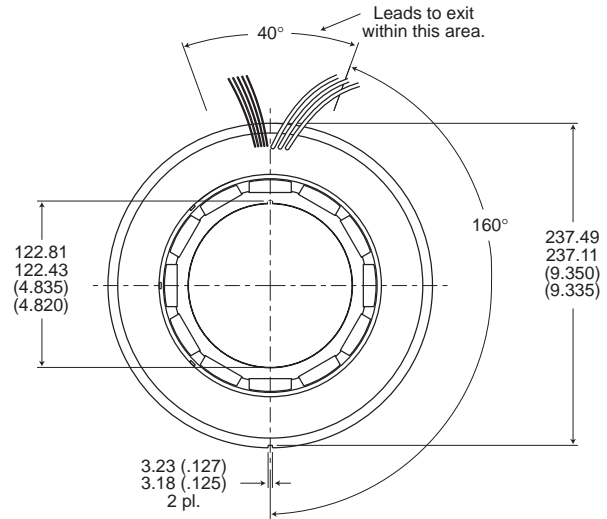
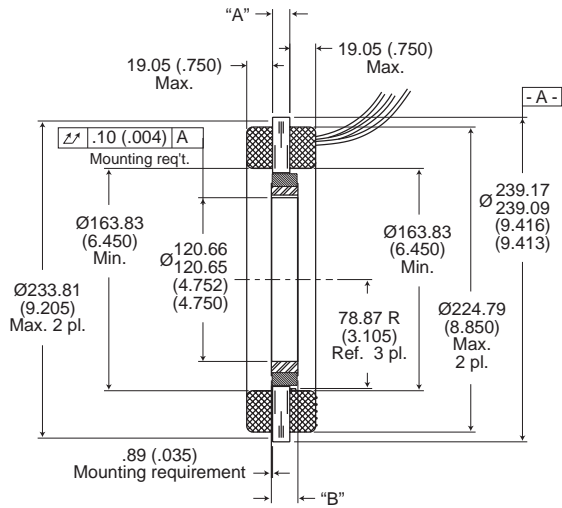

Dimensions in mm (inches).
Product designed in inches.
Metric conversions provided for reference only.

Notes:

- For a C.W. rotation, as viewed from lead end, energize per excitation sequence table.
- V-AB, V-BC and V-CA is back EMF of motor phases AB, BC and CA respectively, aligned with sensor output as shown for C.W. rotation only.
- Mounting surface is between Ø 233.81 (9.205) and Ø 239.17 (9.416) on both sides.

MODEL NUMBER	RBE-06210	RBE-06211	RBE-06212
"A" Dimension	12.7 (0.500)	29.21 (1.150)	45.72 (1.800)
"B" Dimension	19.56 (0.770)	36.07 (1.420)	52.58 (2.070)
Tolerance ± .010 on "A" Dimension.			

RBEH-0621X-X00

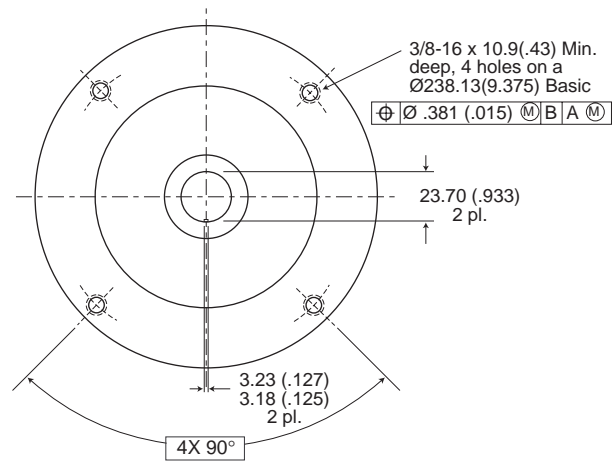
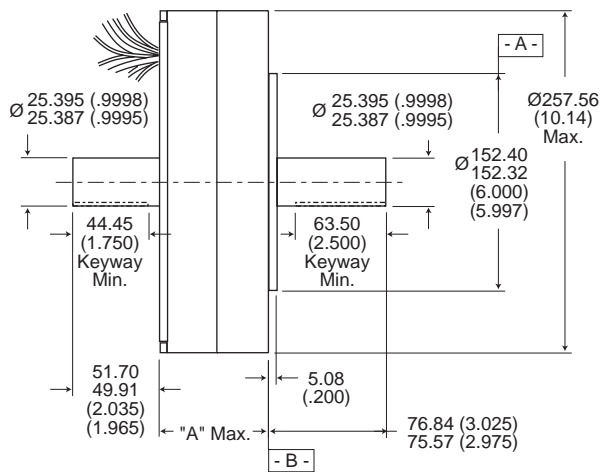

Dimensions in mm (inches).
Product designed in inches.
Metric conversions provided for reference only.

Notes:

- Shaft end play: with a 34 lb reversing load, the axial displacement shall be .013-.15 (.0005-.006).
- For a C.C.W. rotation, as viewed from pilot end, energize per excitation sequence table.
- V-AB, V-BC and V-CA is back EMF of motor phases AB, BC and CA respectively, aligned with sensor output as shown for C.C.W. rotation only.

MODEL NUMBER	RBEH-06210	RBEH-06211	RBEH-06212
"A" Dimension	82.30 (3.240)	98.81 (3.890)	115.32 (4.540)

RBE/RBEH LEADWIRE

Motor Leads: #12 AWG type Teflon coated per MIL-W-22759/11, 3 leads, 152 (6.00) min. long each 1-black, 1-red, 1-white.

Sensor Leads: #26 AWG type "ET" Teflon coated per MIL-W-16878, 5 leads, 152 (6.00) min long each, 1-blue, 1-brown, 1-green, 1-orange, 1-yellow.

RBE(H) Motor Series

PERFORMANCE CURVES

RBE-00410-A

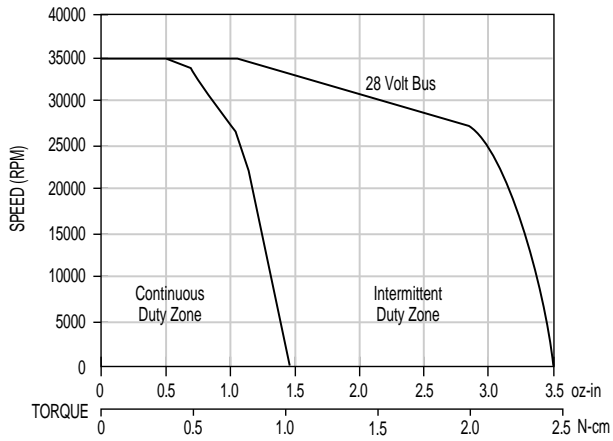

RBE-00412-A

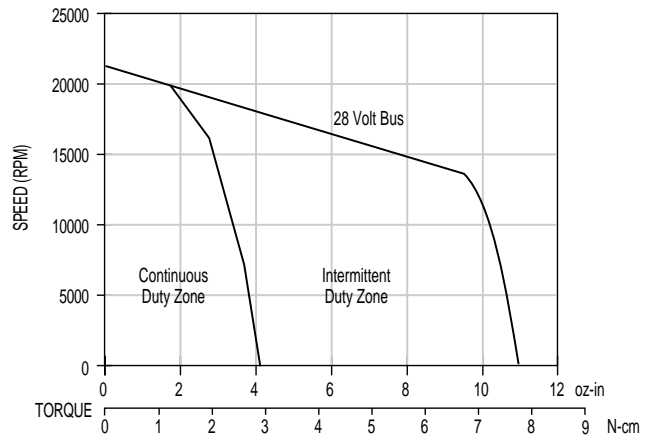

RBE(H) Motor Series

PERFORMANCE CURVES

RBE-00510-A00

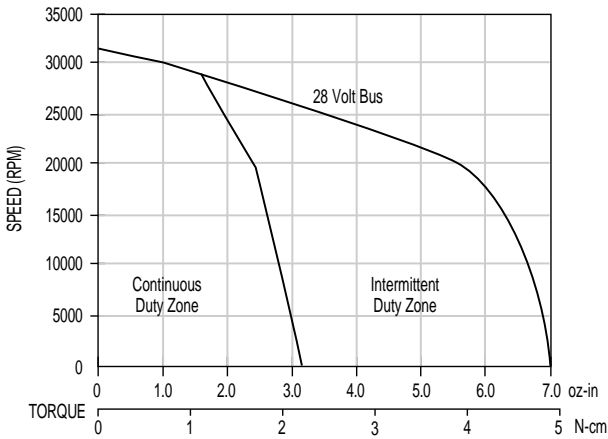

RBE-00510-B00

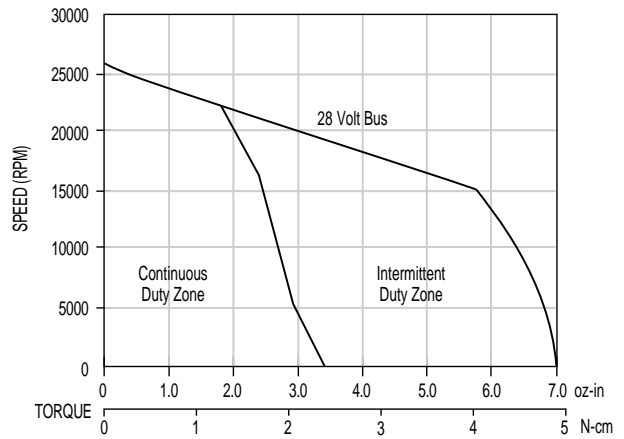

RBE-00513-A00

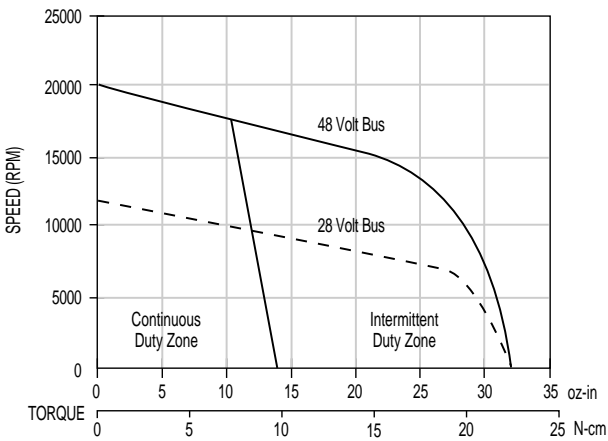

RBE-00513-C00

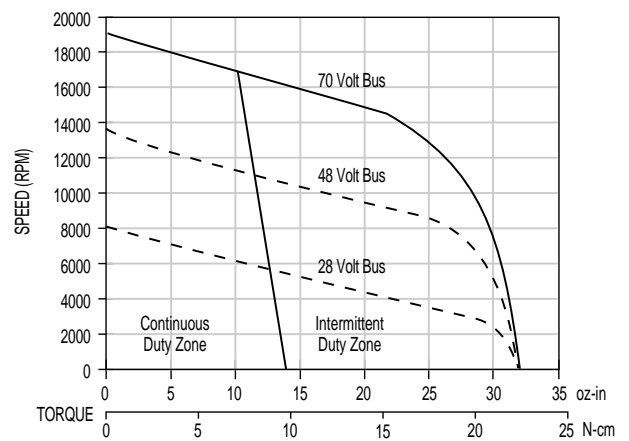

RBE(H) Motor Series

PERFORMANCE CURVES

RBE-00710-A00

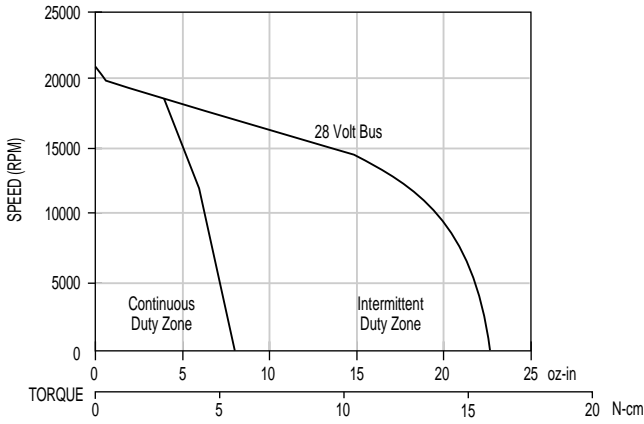

RBE-00710-B00

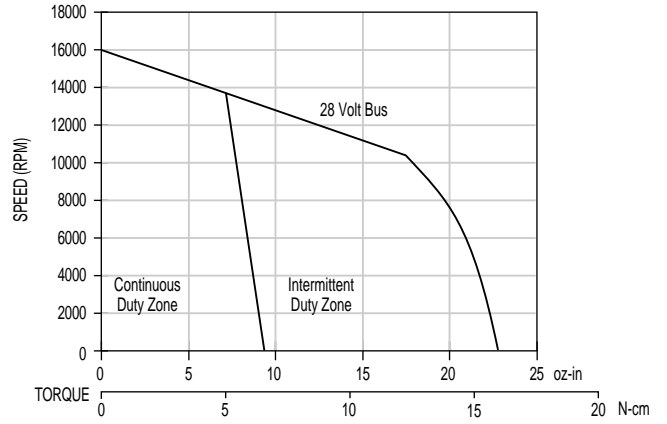

RBE-00714-B00

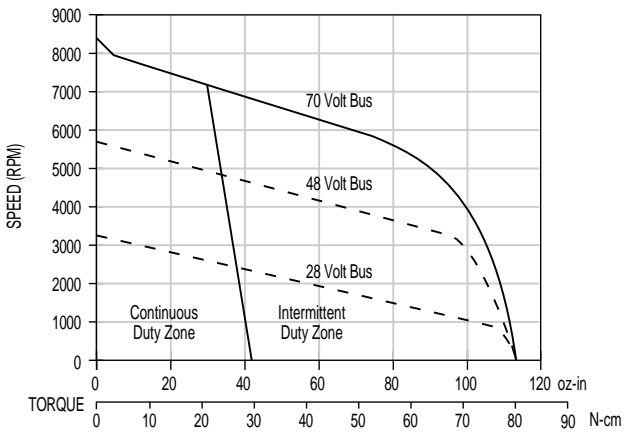

RBE-00714-C00

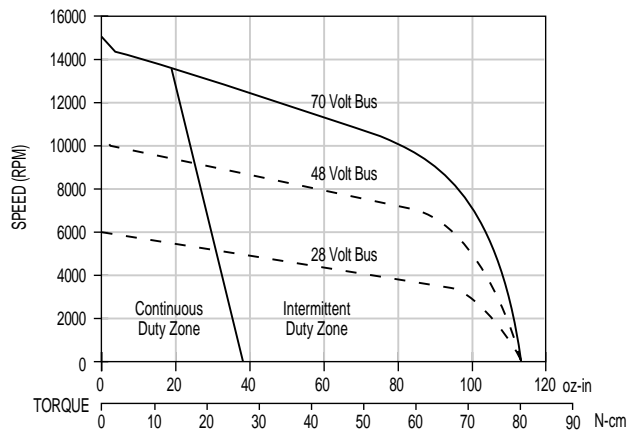

RBE(H) Motor Series

PERFORMANCE CURVES

RBE-01210-B00

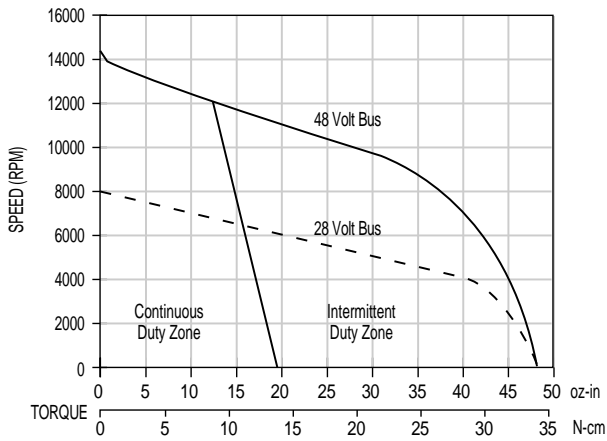

RBE-01210-C00

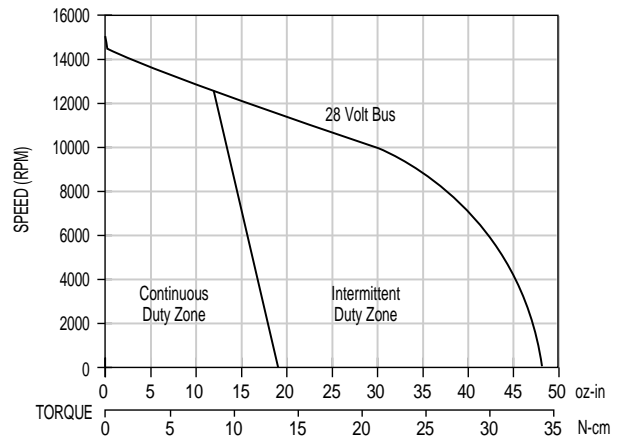

RBE-01215-B00

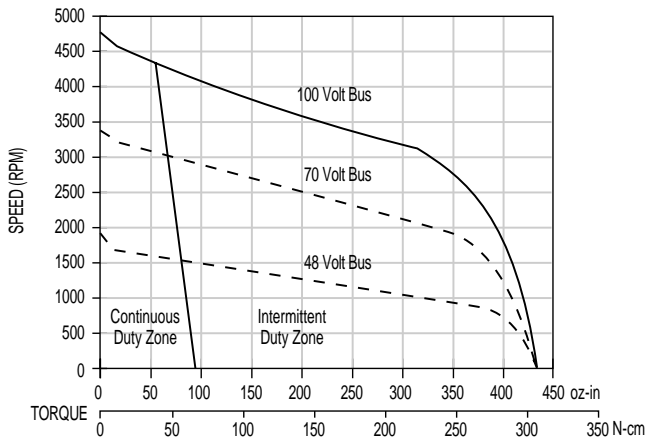

RBE-01215-C00

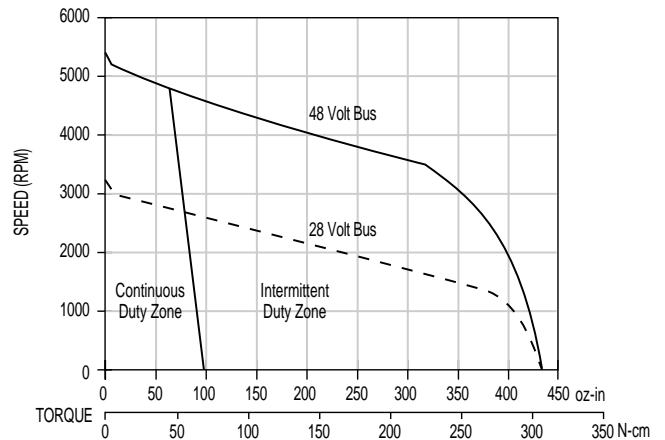

RBE(H) Motor Series

PERFORMANCE CURVES

RBE-01510-B

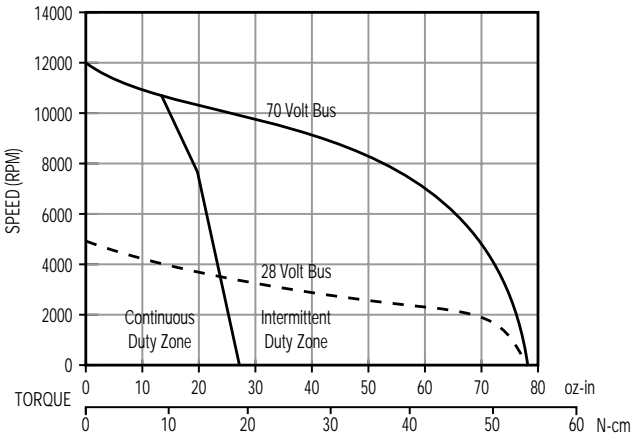

RBE-01510-C

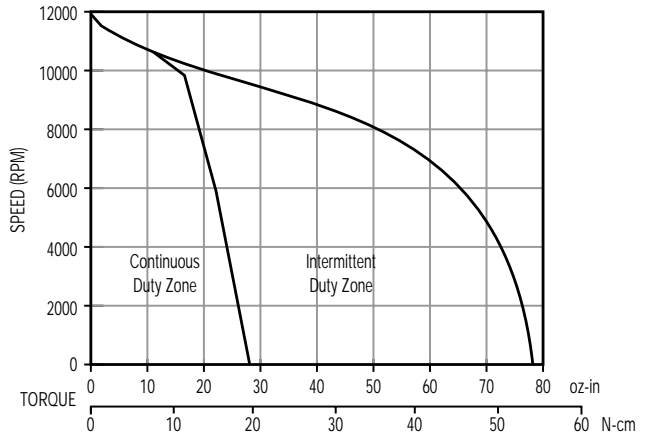

RBE-01516-B

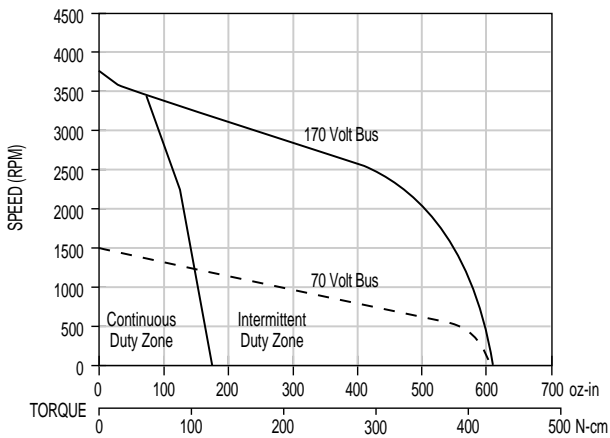

RBE-01516-C

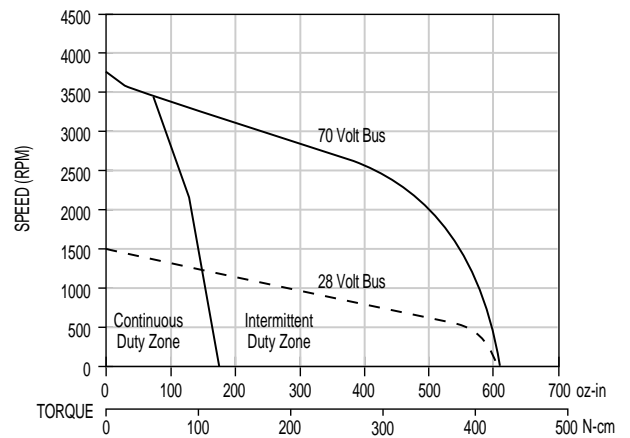

RBE(H) Motor Series

PERFORMANCE CURVES

RBE-01810-B

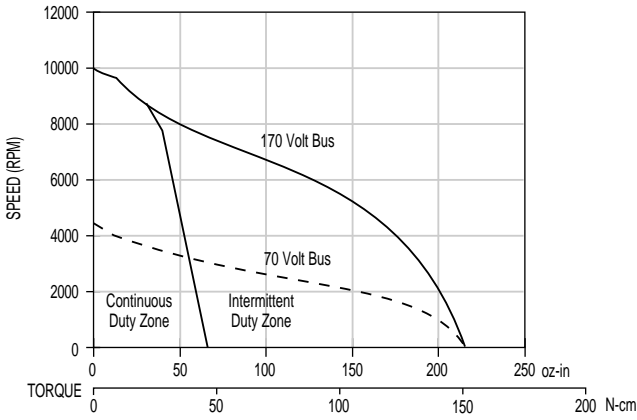

RBE-01810-C

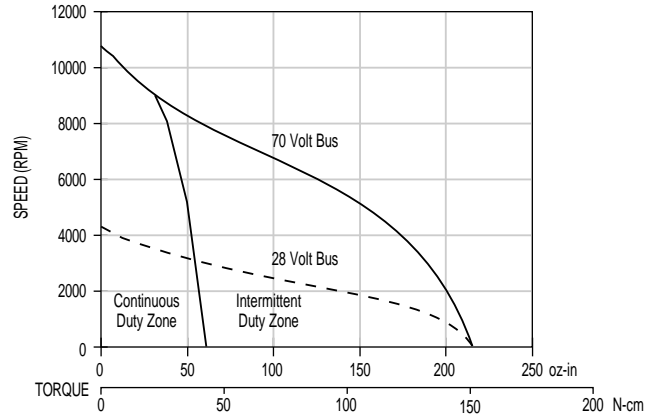

RBE-01815-B

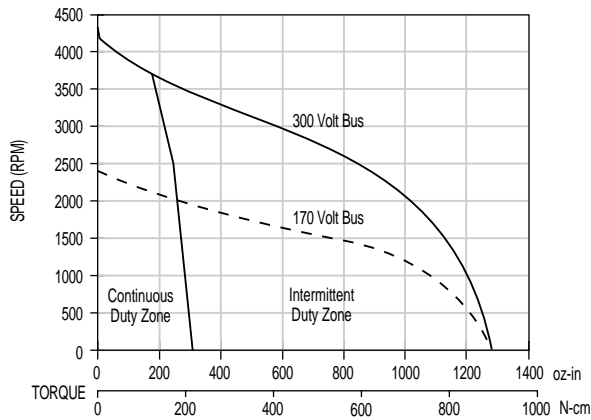

RBE-01815-C

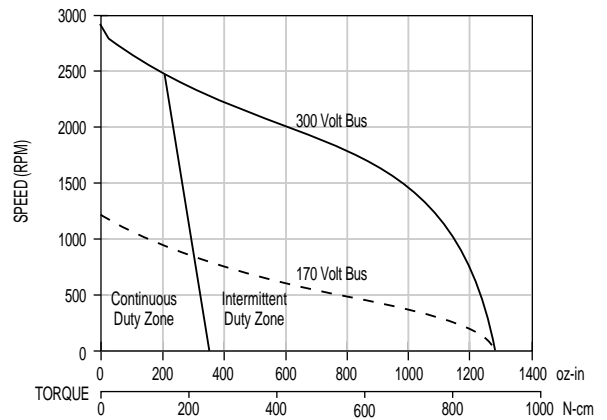

RBE(H) Motor Series

PERFORMANCE CURVES

RBE-02110-B

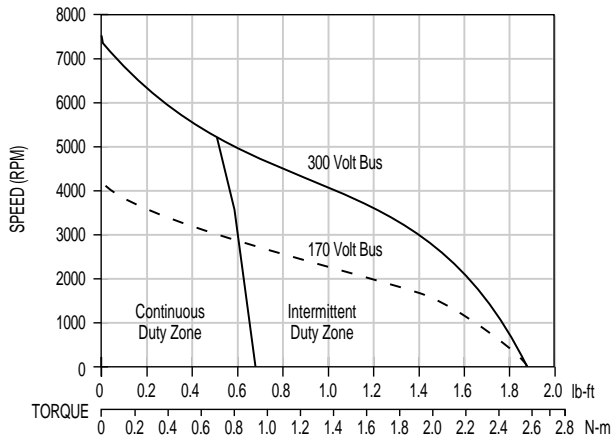

RBE-02110-C

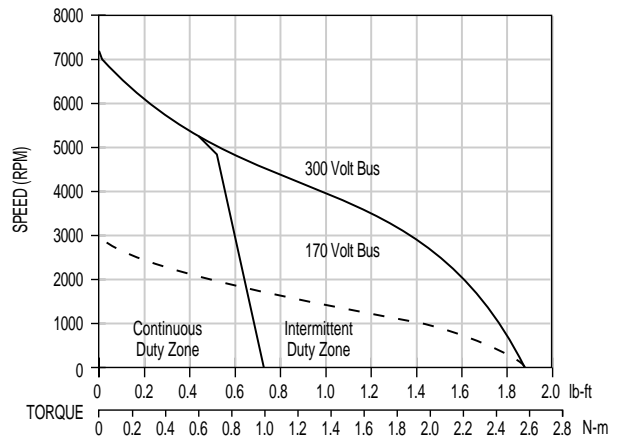

RBE-02115-A

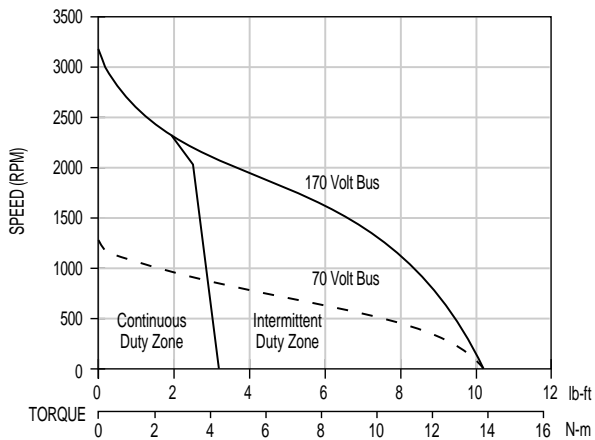

RBE-02115-C

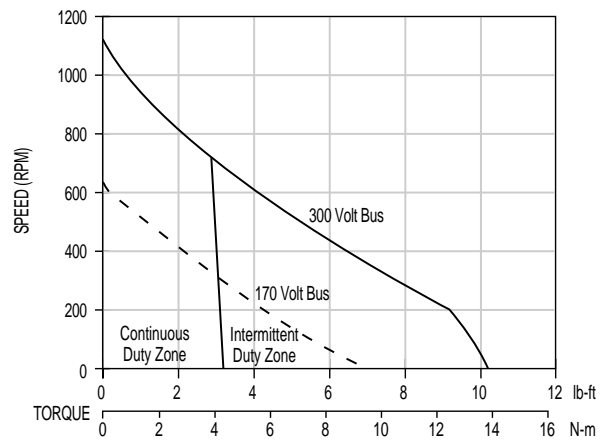

PERFORMANCE CURVES

RBE-03010-A

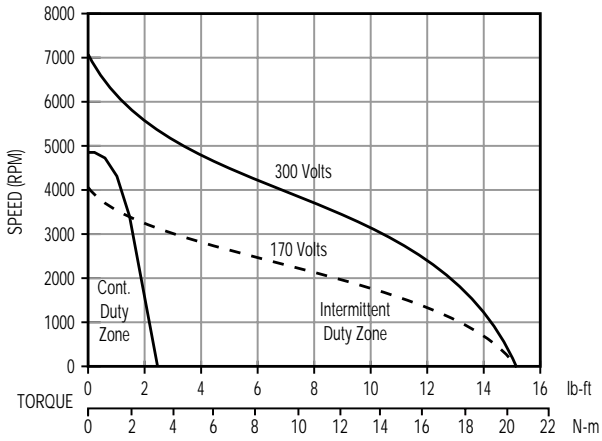

RBE-03016-B

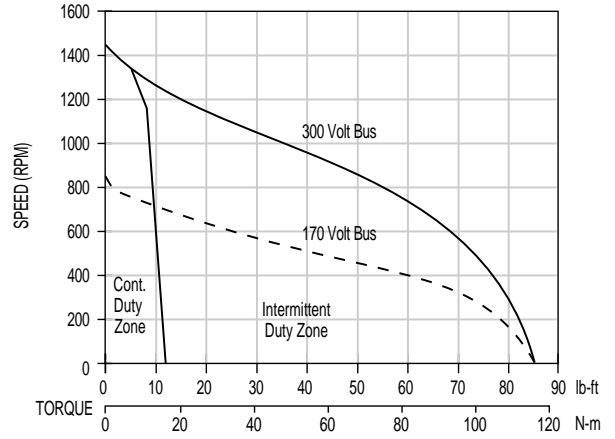

RBE-03016-C

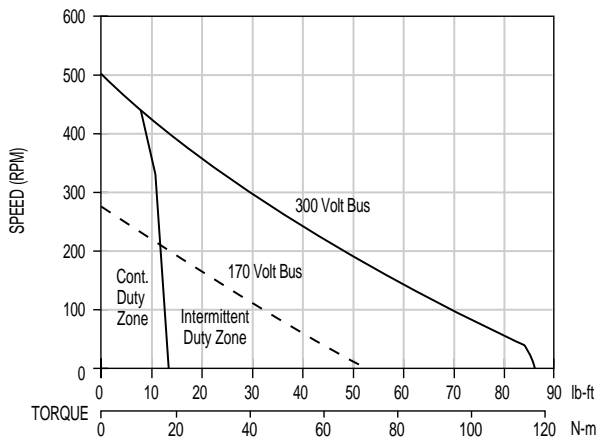

RBE(H) Motor Series

PERFORMANCE CURVES

RBE-04510-B

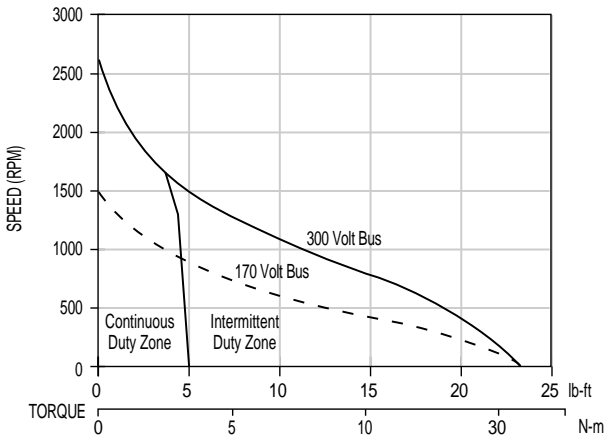

RBE-04510-C

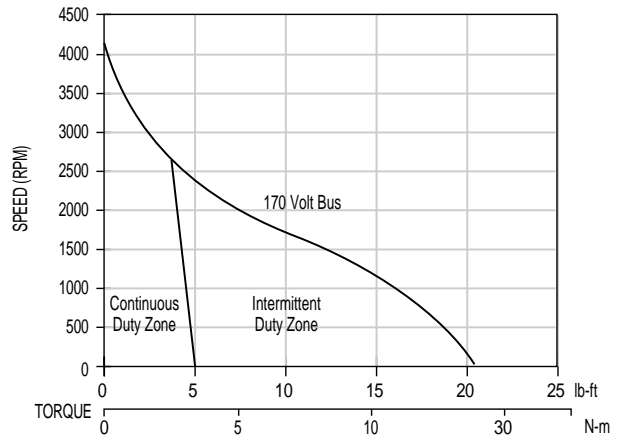

RBE-04512-A

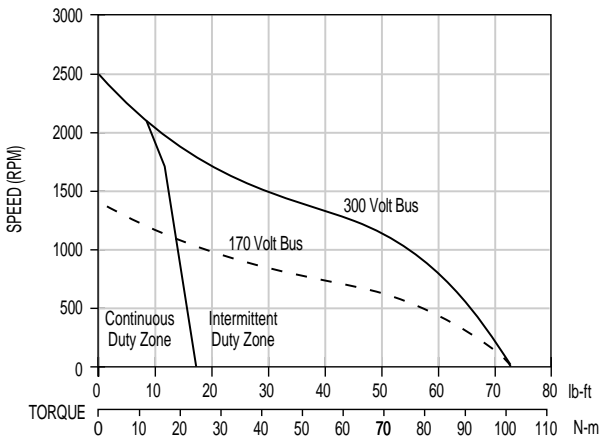

RBE-04512-C

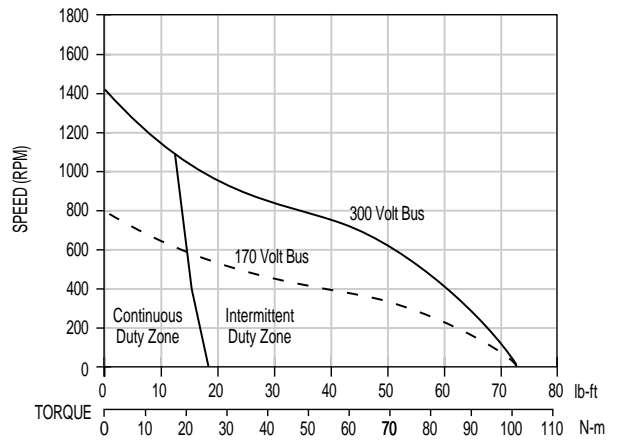

RBE(H) Motor Series

PERFORMANCE CURVES

RBE-06210-A

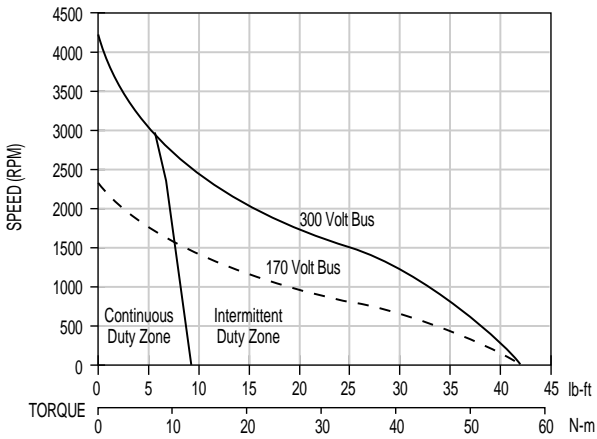

RBE-06210-B

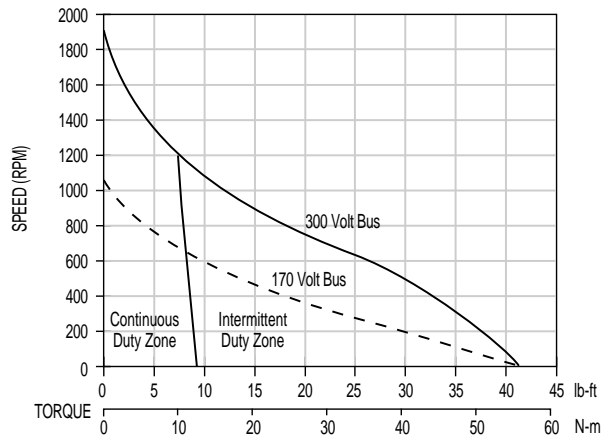

RBE-06212-B

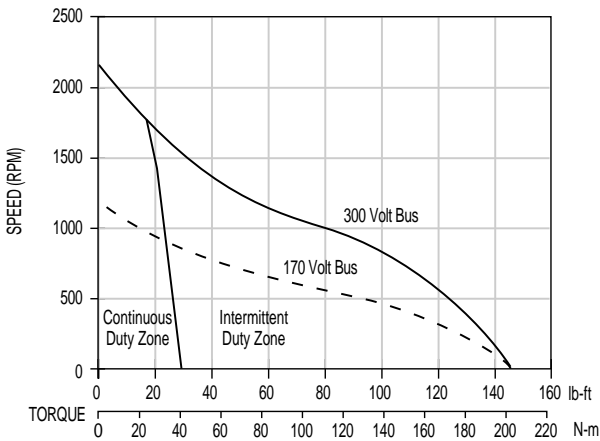

RBE-06212-C

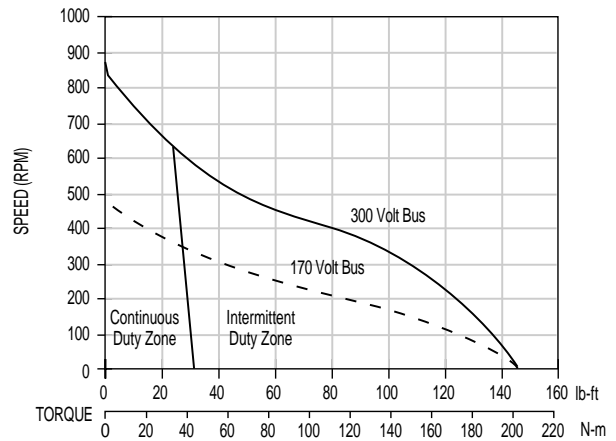

RBE(H) Motor Series

OPTIONS — RBEH-0071X

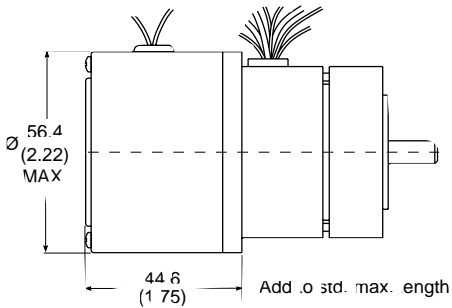

Dimensions in mm (inches).
Product designed in inches.

Metric conversions provided for reference only.

BRAKE OPTION

An integral electromagnetic fail-safe brake can be added to the rear of the motor. Operating in the POWER OFF/BRAKE ON mode, the brake provides 48 oz-in of torque for static parking and emergency braking. To release the brake, 24 VDC and 0.13 Amps max need to be applied.

- Fail-safe brake
- 48 oz-in holding torque
- Release voltage of 24 VDC (0.13 Amps)

RESOLVER OPTION

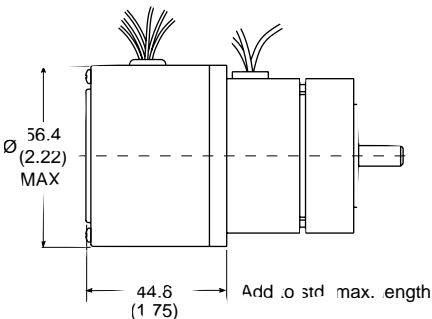

Dimensions in mm (inches).
Product designed in inches.

Metric conversions provided for reference only.

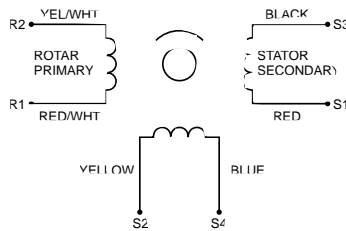

RESOLVER SCHEMATIC

PHASING EQUATIONS
 $E(S1-S3) = KE(R1-R2) \cos \theta$
 $E(S2-S4) = -KE(R1-R2) \sin \theta$
 WITH CCW ROTATION AS VIEWED FROM SHAFT END

NORMAL CHARACTERISTICS AT 25°C

PRIMARY	ROTOR
INPUT VOLTAGE	4.25V, 7 kHz
INPUT CURRENT	55 MA. MAX.
INPUT POWER	0.12 WATTS
TRANSFORMATION RATIO ($\pm 5\%$)	0.470
PHASE SHIFT	4° LEADING $\pm 3^\circ$
IMPEDANCES ($\pm 15\%$)	
Zr0	48 + j70
Zsc	62 + j80
Zss	53 + j63
Zrs	42 + j55
D.C. RESISTANCE ($\pm 10\%$)	
STATOR	33 Ohm
ROTOR	16 Ohm
NULL VOLTAGE	20 MV. MAX.
ELECTRICAL ERROR	± 7 MINUTES MAX.
OUTPUT VOLTAGE	2.0 V $\pm 5\%$
OPERATING TEMPERATURE	-55° TO +155°C

ENCODER OPTION

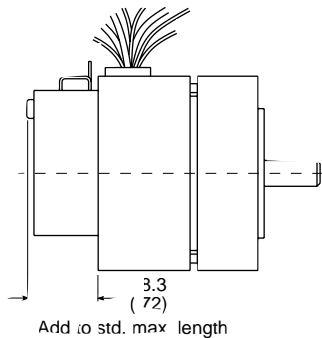

Dimensions in mm (inches).
Product designed in inches.

Metric conversions provided for reference only.

An incremental encoder is available having TTL quadrature and marker pulse outputs. 96 to 1024 lines are available. The standard is 512 lines with the marker pulse.

Parameter	Min	Max	Units
Temperature	-40	100	°C
Supply Voltage	4.5	5.5	Volts
Supply Current	30	85	mA
Count Frequency		100	kHz
Velocity		30K	RPM

Resolution

Cycles/Rev.
096
100
200
250
256
360
400
500
512
540*
1000*
1024*

Index option not yet available for resolutions marked by *

OPTIONS — RBEH-0121X

BRAKE OPTION

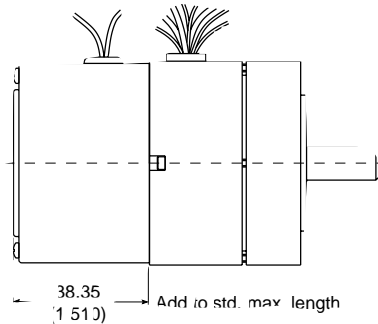

Dimensions in mm (inches).
Product designed in inches.

Metric conversions provided for reference only.

An integral electromagnetic fail-safe brake can be added to the rear of the motor. Operating in the POWER OFF/BRAKE ON mode, the brake provides 48 oz-in of torque for static parking and emergency braking. To release the brake, 24 VDC and 0.13 Amps max need to be applied.

- Fail-safe brake
- 48 oz-in holding torque
- Release voltage of 24 VDC (0.13 Amps)

RESOLVER OPTION

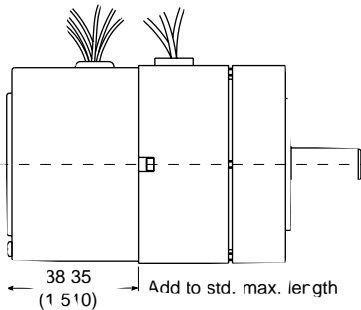

Dimensions in mm (inches).
Product designed in inches.

Metric conversions provided for reference only.

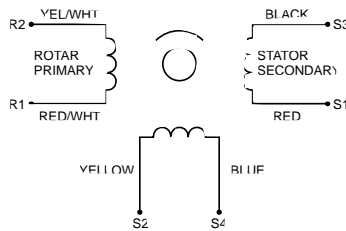

RESOLVER SCHEMATIC

PHASING EQUATIONS
 $E(S1-S3) = KE(R1-R2) \cos \theta$
 $E(S2-S4) = -KE(R1-R2) \sin \theta$
 WITH CCW ROTATION AS
 VIEWED FROM SHAFT END

NORMAL CHARACTERISTICS AT 25°C

PRIMARY	ROTOR
INPUT VOLTAGE	4.25V, 7 kHz
INPUT CURRENT	55 MA. MAX.
INPUT POWER	0.12 WATTS
TRANSFORMATION RATIO (± 5%)	0.470
PHASE SHIFT	4° LEADING ± 3°
IMPEDANCES (± 15%)	
Zr0	48 + j70
Zs0	62 + j80
Zss	53 + j63
Zrs	42 + j55
D.C. RESISTANCE (± 10%)	
STATOR	33 Ohm
ROTOR	16 Ohm
NULL VOLTAGE	20 MV. MAX.
ELECTRICAL ERROR	± 7 MINUTES MAX.
OUTPUT VOLTAGE	2.0 V ± 5%
OPERATING TEMPERATURE	-55° TO +155°C

ENCODER OPTION

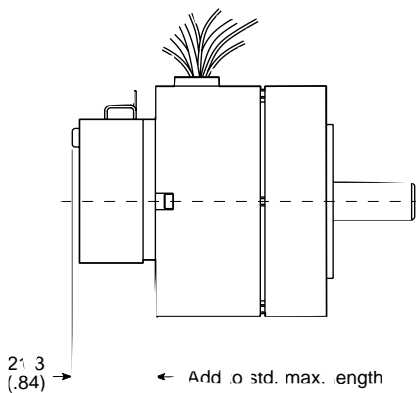

Dimensions in mm (inches).
Product designed in inches.

Metric conversions provided for reference only.

An incremental encoder is available having TTL quadrature and marker pulse outputs. 200 to 2048 lines are available. The standard is 1024 lines with the marker pulse.

Parameter	Min	Max	Units
Temperature	-40	100	°C
Supply Voltage	4.5	5.5	Volts
Supply Current	30	85	mA
Count Frequency		100	kHz
Velocity		10K	RPM

Resolution

Cycles/Rev.
 200
 500*
 1000
 1024
 2000*
 2048*

Index option not yet available for resolutions marked by *

RBE(H) Motor Series

OPTIONS — RBEH-0151X

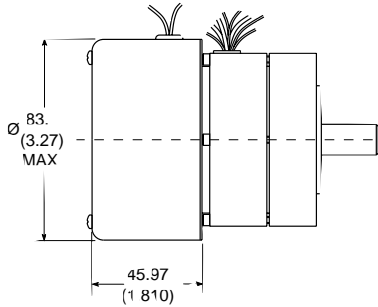

Add .0 std. max. length

Dimensions in mm (inches).
Product designed in inches.

Metric conversions provided for reference only.

BRAKE OPTION

An integral electromagnetic fail-safe brake can be added to the rear of the motor. Operating in the POWER OFF/BRAKE ON mode, the brake provides 240 oz-in of torque for static parking and emergency braking. To release the brake, 24 VDC and 0.30 Amps max need to be applied.

- Fail-safe brake
- 240 oz-in holding torque
- Release voltage of 24 VDC (0.30 Amps)

RESOLVER OPTION

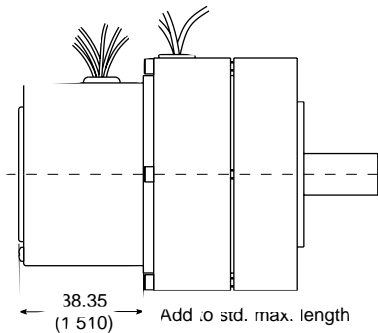

Add .0 std. max. length

Dimensions in mm (inches).
Product designed in inches.

Metric conversions provided for reference only.

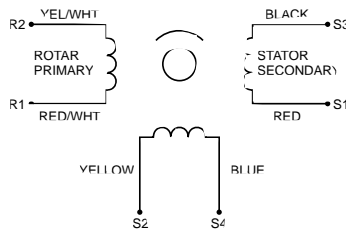

RESOLVER SCHEMATIC

PHASING EQUATIONS
 $E(S1-S3) = K_E(R1-R2) \cos \theta$
 $E(S2-S4) = -K_E(R1-R2) \sin \theta$
 WITH CCW ROTATION AS VIEWED FROM SHAFT END

NORMAL CHARACTERISTICS AT 25°C

PRIMARY	ROTOR
INPUT VOLTAGE	4.25V, 7 kHz
INPUT CURRENT	55 MA. MAX.
INPUT POWER	0.12 WATTS
TRANSFORMATION RATIO (± 5%)	0.470
PHASE SHIFT	4° LEADING ± 3°
IMPEDANCES (± 15%)	
Z _{RO}	48 + j70
Z _{SO}	62 + j80
Z _{SS}	53 + j63
Z _{RS}	42 + j55
D.C. RESISTANCE (± 10%)	
STATOR	33 Ohm
ROTOR	16 Ohm
NULL VOLTAGE	20 MV. MAX.
ELECTRICAL ERROR	± 7 MINUTES MAX.
OUTPUT VOLTAGE	2.0 V ± 5%
OPERATING TEMPERATURE	-55° TO +155°C

ENCODER OPTION

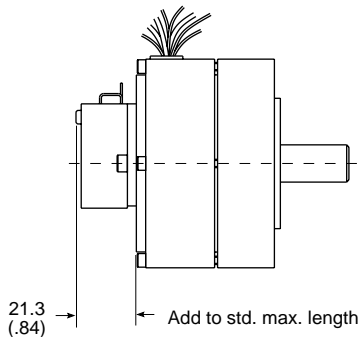

Add to std. max. length

Dimensions in mm (inches).
Product designed in inches.

Metric conversions provided for reference only.

An incremental encoder is available having TTL quadrature and marker pulse outputs. 200 to 2048 lines are available. The standard is 1024 lines with the marker pulse.

Parameter	Min	Max	Units
Temperature	-40	100	°C
Supply Voltage	4.5	5.5	Volts
Supply Current	30	85	mA
Count Frequency		100	kHz
Velocity		10K	RPM

Resolution

Cycles/Rev.
 200
 500*
 1000
 1024
 2000*
 2048*

Index option not yet available for resolutions marked by *

OPTIONS — RBEH-0181X

BRAKE OPTION

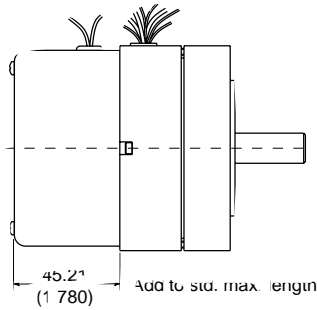

Dimensions in mm (inches).
Product designed in inches.

Metric conversions provided for reference only.

An integral electromagnetic fail-safe brake can be added to the rear of the motor. Operating in the POWER OFF/BRAKE ON mode, the brake provides 240 oz-in of torque for static parking and emergency braking. To release the brake, 24 VDC and 0.30 Amps max need to be applied.

- Fail-safe brake
- 240 oz-in holding torque
- Release voltage of 24 VDC (0.30 Amps)

RESOLVER OPTION

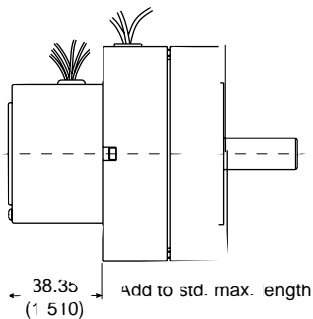

Dimensions in mm (inches).
Product designed in inches.

Metric conversions provided for reference only.

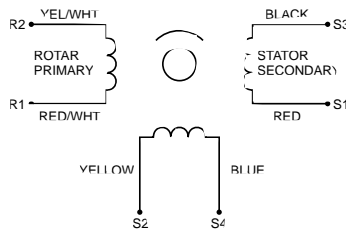

RESOLVER SCHEMATIC

PHASING EQUATIONS
 $E(S1-S3) = KE(R1-R2) \cos \theta$
 $E(S2-S4) = -KE(R1-R2) \sin \theta$
 WITH CCW ROTATION AS VIEWED FROM SHAFT END

NORMAL CHARACTERISTICS AT 25°C

PRIMARY	ROTOR
INPUT VOLTAGE	4.25V, 7 kHz
INPUT CURRENT	55 MA. MAX.
INPUT POWER	0.12 WATTS
TRANSFORMATION RATIO (± 5%)	0.470
PHASE SHIFT	4° LEADING ± 3°
IMPEDANCES (± 15%)	
Z _{RO}	48 + j70
Z _{SO}	62 + j80
Z _{SS}	53 + j63
Z _{RS}	42 + j55
D.C. RESISTANCE (± 10%)	
STATOR	33 Ohm
ROTOR	16 Ohm
NULL VOLTAGE	20 MV. MAX.
ELECTRICAL ERROR	± 7 MINUTES MAX.
OUTPUT VOLTAGE	2.0 V ± 5%
OPERATING TEMPERATURE	-55° TO +155°C

ENCODER OPTION

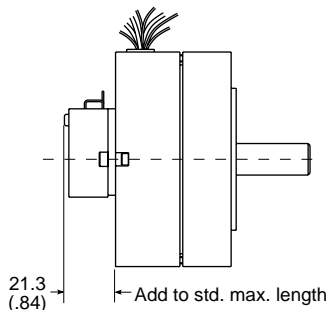

Dimensions in mm (inches).
Product designed in inches.

Metric conversions provided for reference only.

An incremental encoder is available having TTL quadrature and marker pulse outputs. 200 to 2048 lines are available. The standard is 1024 lines with the marker pulse.

Parameter	Min	Max	Units
Temperature	-40	100	°C
Supply Voltage	4.5	5.5	Volts
Supply Current	30	85	mA
Count Frequency		100	kHz
Velocity		10K	RPM

Resolution

Cycles/Rev.
 200
 500*
 1000
 1024
 2000*
 2048*

Index option not yet available for resolutions marked by *

RBE(H) Motor Series

OPTIONS — RBEH-0211X

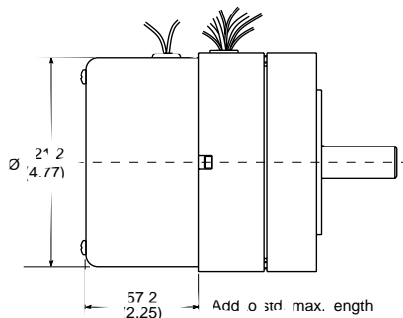

Dimensions in mm (inches).
Product designed in inches.

Metric conversions provided for reference only.

BRAKE OPTION

An integral electromagnetic fail-safe brake can be added to the rear of the motor. Operating in the POWER OFF/BRAKE ON mode, the brake provides 4.2 lb-ft of torque for static parking and emergency braking. To release the brake, 24 VDC and 0.39 Amps max need to be applied.

- Fail-safe brake
- 4.2 lb-ft oz-in holding torque
- Release voltage of 24 VDC (0.39 Amps)

RESOLVER OPTION

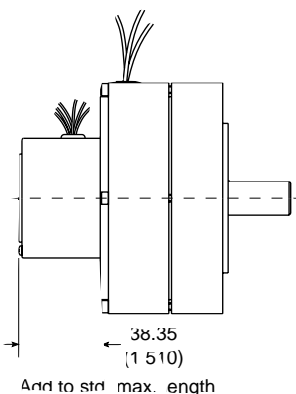

Dimensions in mm (inches).
Product designed in inches.

Metric conversions provided for reference only.

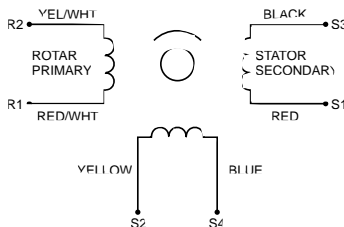

RESOLVER SCHEMATIC

PHASING EQUATIONS
 $E(S1-S3) = KE(R1-R2) \cos \theta$
 $E(S2-S4) = -KE(R1-R2) \sin \theta$
 WITH CCW ROTATION AS
 VIEWED FROM SHAFT END

NORMAL CHARACTERISTICS AT 25°C

PRIMARY	ROTOR
INPUT VOLTAGE	4.25V, 7 kHz
INPUT CURRENT	55 MA. MAX.
INPUT POWER	0.12 WATTS
TRANSFORMATION RATIO (± 5%)	0.470
PHASE SHIFT	4° LEADING ± 3°
IMPEDANCES (± 15%)	
Zr0	48 + j70
Zs0	62 + j80
Zss	53 + j63
Zrs	42 + j55
D.C. RESISTANCE (± 10%)	
STATOR	33 Ohm
ROTOR	16 Ohm
NULL VOLTAGE	20 MV. MAX.
ELECTRICAL ERROR	± 7 MINUTES MAX.
OUTPUT VOLTAGE	2.0 V ± 5%
OPERATING TEMPERATURE	-55° TO +155°C

ENCODER OPTION

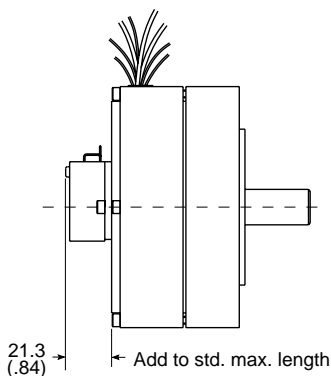

Dimensions in mm (inches).
Product designed in inches.

Metric conversions provided for reference only.

An incremental encoder is available having TTL quadrature and marker pulse outputs. 200 to 2048 lines are available. The standard is 1024 lines with the marker pulse.

Parameter	Min	Max	Units
Temperature	-40	100	°C
Supply Voltage	4.5	5.5	Volts
Supply Current	30	85	mA
Count Frequency		100	kHz
Velocity		10K	RPM

Resolution

Cycles/Rev.
 200
 500*
 1000
 1024
 2000*
 2048*

Index option not yet available for resolutions marked by *

OPTIONS — RBEH-0301X

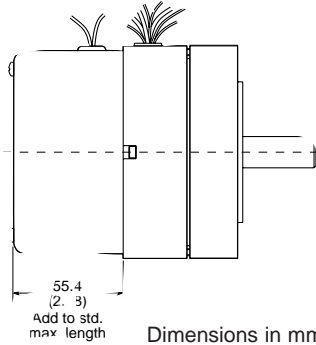

Dimensions in mm (inches).
Product designed in inches.

Metric conversions provided for reference only.

BRAKE OPTION

An integral electromagnetic fail-safe brake can be added to the rear of the motor. Operating in the POWER OFF/BRAKE ON mode, the brake provides 4.2 lb-ft of torque for static parking and emergency braking. To release the brake, 24 VDC and 0.39 Amps max need to be applied.

- Fail-safe brake
- 4.2 lb-ft oz-in holding torque
- Release voltage of 24 VDC (0.39 Amps)

RESOLVER OPTION

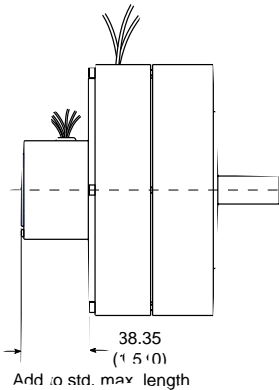

Dimensions in mm (inches).
Product designed in inches.

Metric conversions provided for reference only.

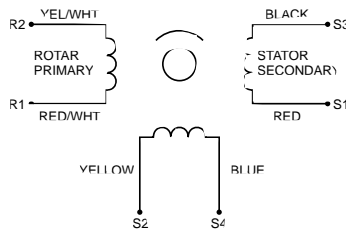

RESOLVER SCHEMATIC

PHASING EQUATIONS
 $E(S1-S3) = K_E(R1-R2) \cos \theta$
 $E(S2-S4) = -K_E(R1-R2) \sin \theta$
 WITH CCW ROTATION AS VIEWED FROM SHAFT END

NORMAL CHARACTERISTICS AT 25°C

PRIMARY	ROTOR
INPUT VOLTAGE	4.25V, 7 kHz
INPUT CURRENT	55 MA. MAX.
INPUT POWER	0.12 WATTS
TRANSFORMATION RATIO (± 5%)	0.470
PHASE SHIFT	4° LEADING ± 3°
IMPEDANCES (± 15%)	
Z _{r0}	48 + j70
Z _{s0}	62 + j80
Z _{ss}	53 + j63
Z _{rs}	42 + j55
D.C. RESISTANCE (± 10%)	
STATOR	33 Ohm
ROTOR	16 Ohm
NULL VOLTAGE	20 MV. MAX.
ELECTRICAL ERROR	± 7 MINUTES MAX.
OUTPUT VOLTAGE	2.0 V ± 5%
OPERATING TEMPERATURE	-55° TO +155°C

ENCODER OPTION

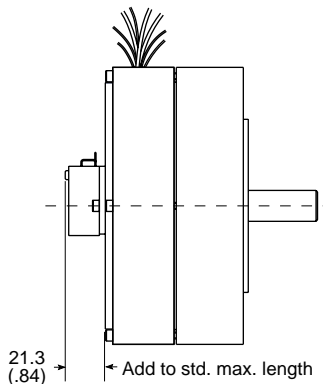

Dimensions in mm (inches).
Product designed in inches.

Metric conversions provided for reference only.

An incremental encoder is available having TTL quadrature and marker pulse outputs. 200 to 2048 lines are available. The standard is 1024 lines with the marker pulse.

Parameter	Min	Max	Units
Temperature	-40	100	°C
Supply Voltage	4.5	5.5	Volts
Supply Current	30	85	mA
Count Frequency		100	kHz
Velocity		10K	RPM

Resolution

Cycles/Rev.
 200
 500*
 1000
 1024
 2000*
 2048*

Index option not yet available for resolutions marked by *

RBE(H) Motor Series

COMMUTATION AND CONNECTION DIAGRAMS

MOTOR WIRING DIAGRAM

Phase "A"	Red Lead
Phase "B"	White Lead
Phase "C"	Black Lead

SENSOR WIRING DIAGRAM

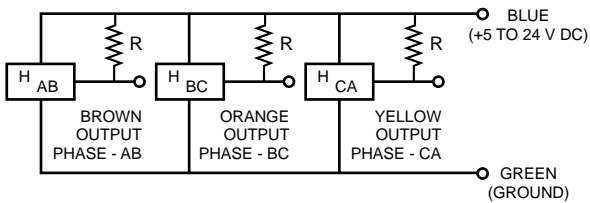

MOTOR EXCITATION SEQUENCE AND SENSOR OUTPUT LOGIC FOR C.W. ROTATION VIEWING LEADWIRE END

EXCITATION STEP	1	2	3	4	5	6	1
Motor Leads (RED) A (WHT) B (BLK) C	+	+	-	-	+	+	-
Sensor Outputs (BRN) A (ORG) B (YEL) C	1	1	0	0	1	1	0

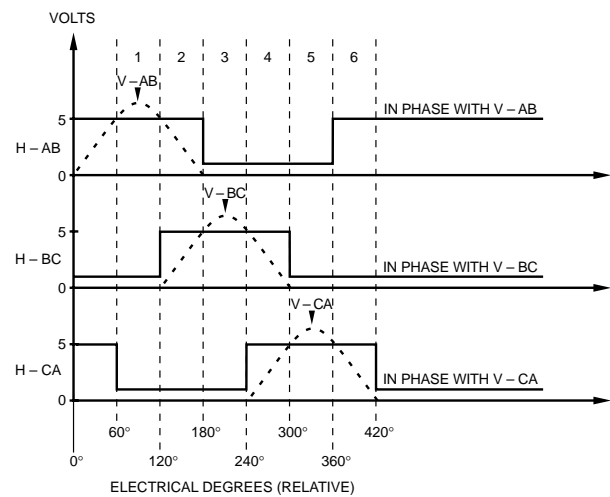

SENSOR AND MOTOR PHASE OUTPUT

RBE(H) Motor Series

ORDERING INFORMATION

