

MX80L Linear Servo Motor Driven Stages

Features

- Miniature size
- 5 g acceleration
- Fast settling
- Submicron precision
- High velocity (2 m/sec.)
- Multi-axis platform

Attributes

- Low profile miniature size - (25 mm high X 80 mm wide)
- Linear servo motor drive
- Six linear encoder resolutions (0.01 μm to 5.0 μm)
- 25, 50, 100, 150 and 200 mm travels
- Cross Roller bearing (zero cage creep design)
- Precision or standard grade
- Cleanroom and low ESD options
- Fully adjustable home and limit sensors
- Dowel holes for repeatable mounting of payload
- Master reference surface to travel path
- "Plug-in" intelligent drive
- Pneumatic z-axis counterbalance
- No moving cables

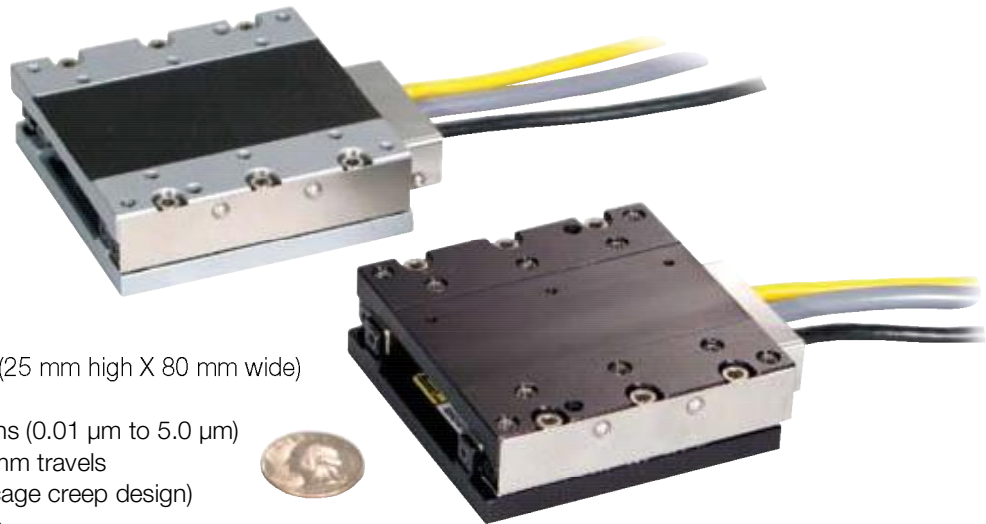

Miniaturization of fiber optics, photonics, electronics and biomedical processes has driven the need for smaller and more efficient positioners. Parker's MX80 miniature stage, the smallest linear servomotor driven positioner in the industry, is loaded with high-performance features for both rapid linear translation and precise positioning of lighter loads in small work envelopes. Designed for today's 24/7 production demands, the MX80 has redefined "high-throughput automation" in the world of miniature positioners.

Cross Roller Bearings
provide high stiffness and extremely smooth linear translation. A rack and pinion anti-cage creep design within the bearing races prevents cage creep even at 5g acceleration, or with cantilevered loads.

Optical Linear Encoders
are available in six standard resolutions (10 nm, 20 nm, 0.1 μm , 0.5 μm , 1.0 μm , 5.0 mm) and is fully integrated within the body of the stage. The non-contact design offers long life and clean operation.

Linear Servo Motor
features a patent pending ironcore design that provides high thrust density for linear acceleration to 5g's and velocities to 2 meters/second. The non-contact design offers long life and clean operation.

Master Reference Surface
is a feature unique to the MX80 that enables customers to align their process to the actual travel path within microns.

Home/Limit Sensors
are magnetic sensors completely housed within the body of the stage, and fully adjustable over the entire travel range.



High Performance in a Small Package

While the MX80 is small in size, it is large on performance and reliability. All key components are “built-in” – residing within the body of the stage to provide a clean looking, reliable, unobstructed package. At the heart of the MX80 is an innovative non-contact linear servo motor (patent pending). This direct drive motor has been optimized for force, speed, and acceleration, to deliver outstanding performance and response. A high-precision non-contact linear encoder provides submicron resolution, repeatability and accuracy.

Selectable resolutions range from 10 nanometers to 5 microns. Precision ground cross roller bearing sets with a “zero cage creep” feature provide extremely smooth, precise linear translation. Digital Hall effect travel limit and home sensors are conveniently designed into the unit for easy adjustment over the entire travel of the stage. Although there are no moving cables, a meter of high-flex cabling is included and wired directly into the units. This high-flex cabling addresses cable flexing concerns associated with the second or third axis in multi-axis system.

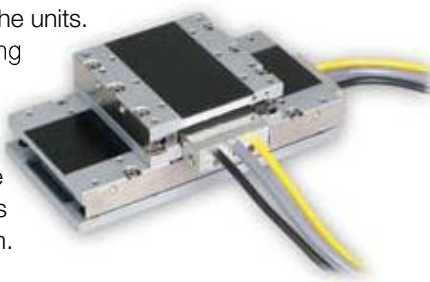

Zero Cage Creep Feature

High acceleration and smooth translation are both desired attributes in a linear-motor stage. The cross roller bearing system found in the MX80 provides extremely smooth linear translation, and with an anti-cage creep design, operates very well in high acceleration applications. This design employs a rack and pinion feature within the bearing races to eliminate bearing creep. As a result, the MX80 performs well, even at 5g acceleration.



Tooling Features

Innovative tooling features make mounting and alignment much quicker and easier.

- A hardened steel master reference surface is provided along the side of the stage to allow fixturing or other tooling elements to be precisely aligned with the actual travel path.
- Two dowel pin holes are provided on the carriage top and base for repeatable mounting of positioner or tooling.



Miniature Positioners

MX80LP Precision Series



- 4 g acceleration
- Repeatability to $\pm 0.4 \mu\text{m}$
- Straightness 4μ
- Steel body construction
- Precision ground mounting and bearing surfaces
- Electroless nickel protective finish

Precision grade models are designed for high-performance applications requiring the highest degree of positioning accuracy. They offer a steel body design with precisely ground mounting surfaces & bearing ways. They include higher resolution linear encoders, and are slope corrected, laser tested and certified for optimum precision.

MX80LS Standard Series



- 5 g acceleration
- Repeatability to $\pm 0.8 \mu\text{m}$
- Straightness 6μ
- Steel body construction
- Light weight aluminum body
- Low luster black anodize finish

Standard grade units offer a lower cost alternative for applications requiring high throughput performance with less demanding positioning requirements. They are constructed of high alloy aluminum, providing a lighter weight design which can accelerate to 5 g's.



		MX80LP Precision Grade				MX80LS Standard Grade				
Travel (mm)		25	50	100	150	25	50	100	150	200
Normal Load Capacity	kg (lb)	8 (18)	8 (18)	8 (18)	8 (18)	8 (18)	8 (18)	8 (18)	8 (18)	8 (18)
Maximum Acceleration	mm/sec ²	1544	1544	1544	1158	1930	1930	1930	1544	1175
Maximum Velocity										
5.0 µm		1100	1500	2000	2000	1100	1500	2000	2000	2000
1.0 µm		1100	1500	2000	2000	1100	1500	2000	2000	2000
0.5 µm	mm/sec ²	1100	1500	1500	1500	1100	1500	1500	1500	1500
0.1 µm		300	300	300	300	300	300	300	300	300
0.02 µm		60	60	60	60	60	60	60	60	60
0.01 µm		30	30	30	30	30	30	30	30	30
Peak Force	N (lb)	12 (2.7)	12 (2.7)	24 (5.4)	24 (5.4)	12 (2.7)	12 (2.7)	24 (5.4)	24 (5.4)	24 (5.4)
Continuous Force	N (lb)	4 (0.9)	4 (0.9)	8 (1.8)	8 (1.8)	4 (0.9)	4 (0.9)	8 (1.8)	8 (1.8)	8 (1.8)
Duty Cycle	%	100	100	100	100	100	100	100	100	100
Straightness & Flatness	µm	4	4	5	6	6	6	10	12	14
Positional Accuracy*										
5.0 µm		13	14	15	15	25	30	35	35	35
1.0 µm		5	6	7	7	15	20	25	25	25
0.5 µm	µm	4	5	6	6	12	15	20	20	20
0.1 µm		3	4	5	5	12	15	20	20	20
0.02 µm		3	4	5	5	12	15	20	20	20
0.01 µm		3	4	5	5	12	15	20	20	20
Bi-directional Repeatability*										
5.0 µm		±10.0	±10.0	±10.0	±10.0	±10.0	±10.0	±10.0	±10.0	±10.0
1.0 µm		±2.0	±2.0	±2.0	±2.0	±2.0	±2.0	±2.0	±2.0	±2.0
0.5 µm	µm	±1.0	±1.0	±1.0	±1.0	±1.0	±1.0	±1.0	±1.0	±1.0
0.1 µm		±0.5	±0.5	±0.5	±0.5	±0.5	±0.5	±0.5	±0.5	±0.7
0.02 µm		±0.4	±0.4	±0.4	±0.4	±0.4	±0.4	±0.4	±0.4	±0.5
0.01 µm		±0.4	±0.4	±0.4	±0.4	±0.4	±0.4	±0.4	±0.4	±0.5
Unit Mass	g	590	590	1027	1345	475	475	875	1125	1370
Carriage Mass (unloaded)	g	282	282	509	676	213	213	405	537	695

* Notes:

- (1) Measured at the carriage center, 35 mm above the mounting surface @ 20 C with no load. Unit bolted to granite surface, flat to within 1 micron/300 mm.
- (2) Total accuracy and bi-directional repeatability over full travel (peak to peak).
- (3) Precision grade with slope correction value provided. Consult factory if better accuracy is required.

(1) Total accuracy and bi-directional repeatability over full travel (peak to peak).



Force - Speed

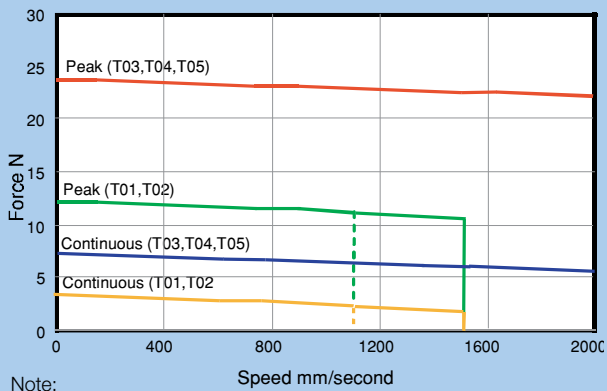

Note:
 T01 (25 mm travel) is limited to a maximum speed of 1100 mm/sec.
 T02 (50 mm) is limited to 1500 (due to limited travel).

Life - Load (Normal Load)

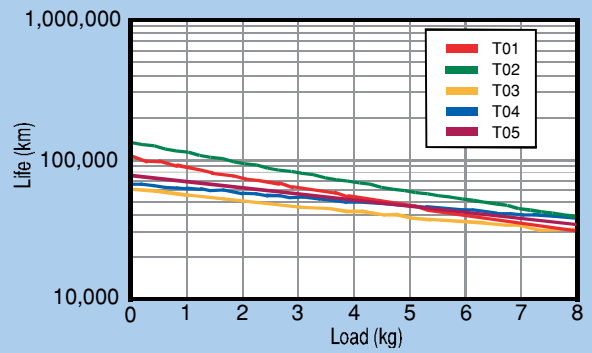

Distance vs Time

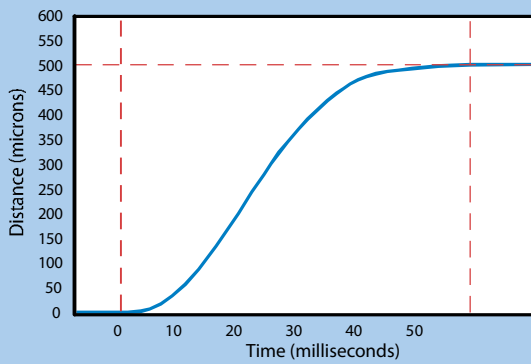

Note: 1 Kg payload, 500 micron move:
 Move and settle to within 1 micron in 47 milliseconds.

Velocity Ripple

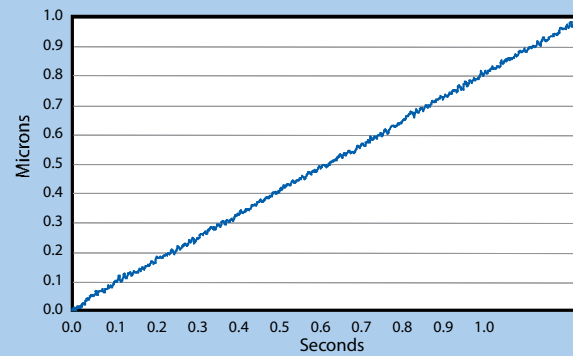

Note: Test were performed using a model MX80LT04D13E8 with a 20 nanometer linear encoder

Simple Configuration Digital Drive Options

All digital drives ordered in the MX80 part number configuration come set up with a motor file including electrical parameters to set continuous and peak currents, current loop compensation values, and default gain settings.

Users will have the ability to override these parameters for special application requirements.

Tuning is easy and intuitive for users and is available via a variety of methods. The motor and loading information must be known by the drive to determine the baseline tuning gains. These are simple parameter entries the user can complete with the help of standard Parker supplied front-end software tools. Seamless integration of drives and controls ensures performance matched functionality of the completed motion system.



ViX Intelligent Servo & Microstepping Drives/Controllers

The ViX servo and microstepping drives are the perfect drive solution to be paired with the MX80 family. These drives use advanced field oriented digital control technology to enhance dynamic performance and improve efficiency. In addition to servo and microstepping versions, the ViX family is offered with different levels of control.

ViX Servo Drive

Order Codes: A20 A21 A22

ViX Servo Drive/Controller

Order Codes: A25

XL-PSU Power Supply Module Accessory

The Parker XL-PSU power supply offers a convenient way of powering a ViX series servo drive.



“Plug & Play” Cable Options

Order Codes: CM04 CM05 CM06 CM07

“User convenience” is high on the list of cable attributes found in the MX80. The high-flex cabling and connectors are reliable, durable and offer easy hook-up for “plug and run” installation.



- High-flex cables
- Plug-in compatibility with ViX drive
- CE compliant connectors and shielding
- CE compliant ferrite beads
- Color coded jackets and labeling
- Connectors simplify installation

Encoder Options

Order Codes: E2 E3 E4 E8 E9

A non-contact linear optical encoder provides a quadrature output and offers resolution ranging from 10 nanometer to 5 micron. On the MX80L, the encoder is internal to the stage body. There is no increase to the footprint of the unit and no additional external cabling is required.

Home and Limit Sensor Options

Order Codes: H1 H2 H3 L1 L2 L3

Magnetic home and limit sensors are completely housed within the body of the stage. An innovative design adds functionality without sacrificing geometry. Sensor triggers can be easily adjusted over the travel. The output format is an open collector type capable of sinking up to 50 mA, and be set as N.O. or N.C.

For complete details on drive product features and specifications, please refer to the “Drives & Controllers” section of this catalog.



Cleanroom Option

Order Codes: R2 R20

Both precision and standard grade products can be prepared for cleanroom compatibility. Preparation involves material changes, element modification and cleanroom compatible lubricants. MX80L and MX80S stages with this option are class 10 cleanroom compatible. When applying an XY or XYZ combination in a cleanroom environment, moving wires need to be considered – please consult a Parker application engineer.



Low ESD Coating Option

Order Codes: R10 R20

An optional low ESD electroless nickel or Armoloy coating is offered for improved electrical conductivity, providing a low resistance to ground path for electric discharge.



Environmental Protection Option

Both precision and standard grade units have a hard coat protective finish. The precision units have a hard coat (Rc 78) satin chrome finish, and the standard units have a low luster black anodized finish.

System Orthogonality Option

Order Codes: S2 S3 S4 S5 S6

In any multi-axis positioning system, the perpendicular alignment of the axes must be clearly specified. “Degree of orthogonality” defines the perpendicular alignment of axis one to another. The MX80 offers two choices for orthogonality. As standard, perpendicularity is held to within 60 arc seconds. For more exacting applications the MX80 can be optioned for 15 arc seconds orthogonality.

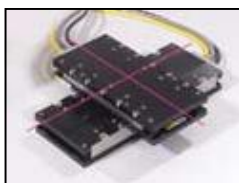

Z-axis Counterbalance Option

Order Codes: X2

A pneumatic Z-axis counterbalance is offered to prevent a sudden load drop if power to the motor is interrupted. A controlled vertical force is applied to the stage top to negate the effect of gravity and achieve equilibrium. A precisely regulated clean air supply of 0 to 60 psi is required for operation. (See Pneumatic Accessory Package)



Pneumatic Accessory Package

This accessory is offered for use with the pneumatic counterbalance option. It consists of a pre-filter, a pressure regulator, a coalescing filter, and a precision regulator to precisely regulate air pressure and remove oil, water or debris down to 3 microns.



Part Number: 002-2236-01

Z-Axis Bracket Accessory

Lightweight aluminum Z-brackets are available for easy construction of vertical axis combinations.

Standard Model Part Numbers:

25 & 50 mm: 002-2238-01
100 & 150 mm: 002-2240-01

Low ESD Model Part Numbers:

5 & 50 mm: 002-2239-01
100 & 150 mm: 002-2241-01

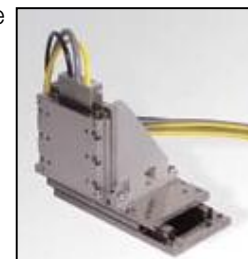

Dimensions (mm)

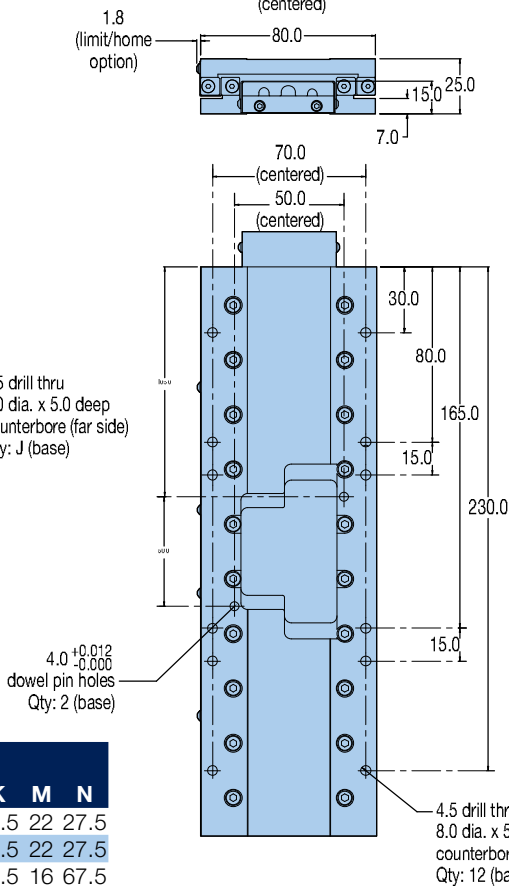
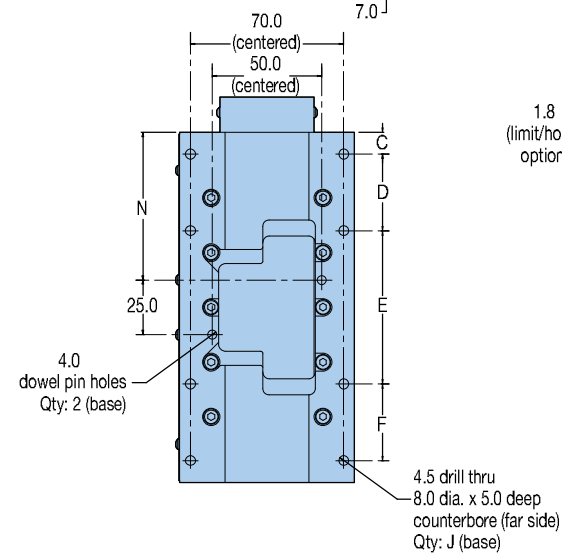
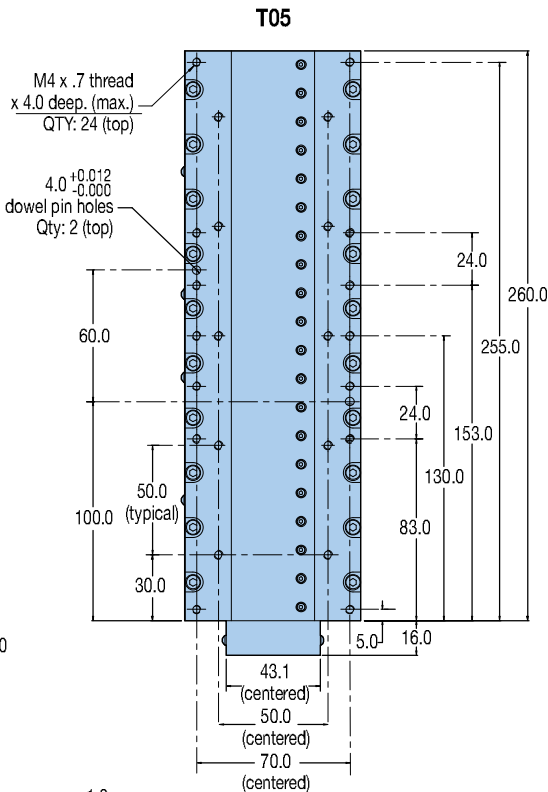
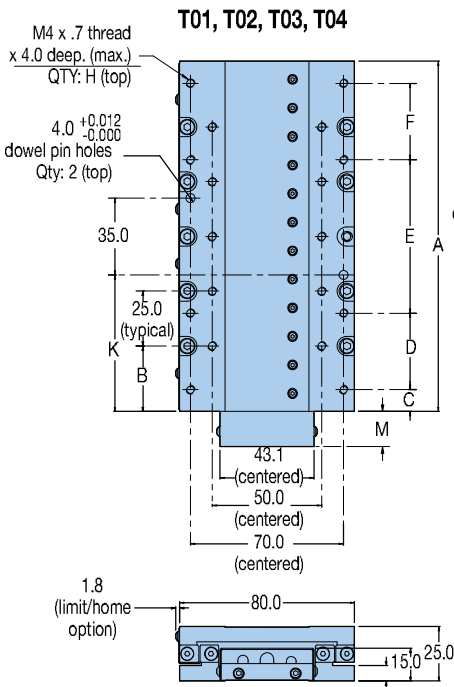

Dimensions (mm)											
Travel	A	B	C	D	E	F	H	J	K	M	N
25	80	15	5	70	—	—	10	4	22.5	22	27.5
50	80	15	5	70	—	—	10	4	22.5	22	27.5
100	160	30	10	35	70	35	18	8	62.5	16	67.5
150	210	30	5	65	70	65	22	8	87.5	16	92.5

Z-axis

Travel	Dim Z
25	166
50	166
100	251
150	326
200	—

Pneumatic Vertical Axis Counter Balance

Travel	Dim X
25	156.6
50	156.6
100	230.6
150	310.6
200	—



Fill in an order code from each of the numbered fields to create a complete model order code.

①	②	③	④	⑤	⑥	⑦	⑧	⑨	⑩	⑪	⑫	⑬	⑭	
Order Example:	MX80L	T02	M	P	-D11	H3	L2	CM05	Z3	E8	R1	A25	X1	S1

- | | |
|--|---|
| <p>① Series
MX80L</p> <p>② Travel – mm
T01 25
T02 50
T03 100
T04 150
T05 200</p> <p>③ Mounting
M Metric</p> <p>④ Grade
S Standard
P Precision (not available with T05 Travel option)</p> <p>⑤ Drive Type
D1 Free Travel (No Motor)
D11 4 Pole (25 & 50 mm travel only)
D13 8 Pole (100, 150 & 200 mm travel only)</p> <p>⑥ Home Sensor
H1 None-Free Travel (only)
H2 N.C. Current Sinking
H3 N.O. Current Sinking</p> <p>⑦ Limit Sensor
L1 None-Free Travel (only)
L2 N.C. Current Sinking
L3 N.O. Current Sinking</p> <p>⑧ Cable Options
CM03 No Cables – Free Travel
CM04 High-Flex Cables w/ViX Connector (1 meter)
CM05 High-Flex Cables w/ViX Connector (3 meter)
CM06 High-Flex Cables w/ViX Connector, no limit/home cable (1 meter)
CM07 High-Flex Cables w/ViX Connector, no limit/home cable (3 meter)</p> <p>⑨ Z Channel Location
Z1 None
Z3 Center Position</p> | <p>⑩ Digital Linear Encoder Option
E1 None
E2 1.0 μm Resolution
E3 0.5 μm Resolution
E4 0.1 μm Resolution
E8 0.02 μm Resolution (20 nanometer)
E9 0.01 μm Resolution (10 nanometer)</p> <p>⑪ Environmental
R1 Standard Finish (black anodized)
R2 Cleanroom Prep
R10 Low ESD Finish
R20 Low ESD Finish & Cleanroom Prep</p> <p>⑫ Digital Drive
A1 No Drive
A20 ViX250-AH (force mode)
A21 ViX250-AH (velocity mode)
A12 ViX250-AH (step/direction mode)
A25 ViX250-IH Drive/Controller</p> <p>⑬ Other Options
X1 None
X2 Z-axis Pneumatic Counter Balance*
* Not available with T05 Travel.</p> <p>⑭ Axis Designator
S1 None (single-axis)
S2 X-axis base unit (cables @ 12 o'clock)
S3 Y-axis 60 arc-sec (cables @ 3 o'clock)
S4 Y-axis 60 arc-sec (cables @ 9 o'clock)
S5 Y-axis 15 arc-sec (cables @ 3 o'clock)
S6 Y-axis 15 arc-sec (cables @ 9 o'clock)</p> |
|--|---|

Miniature Positioners