

MODEL	LENGTH STATOR	LENGTH ROTOR NO HALLS	LENGTH ROTOR WITH HALLS
MF0210010	0.390 (9.9)	0.390 (9.9)	0.515 (13.08)
MF0210025	1.020 (25.9)	1.020 (25.9)	1.145 (29.08)
MF0210050	2.000 (50.9)	2.000 (50.9)	2.125 (53.98)
MF0210075	2.990 (75.9)	2.990 (75.9)	3.115 (79.12)
MF0210100	3.970 (100.9)	3.970 (100.9)	4.095 (104.01)

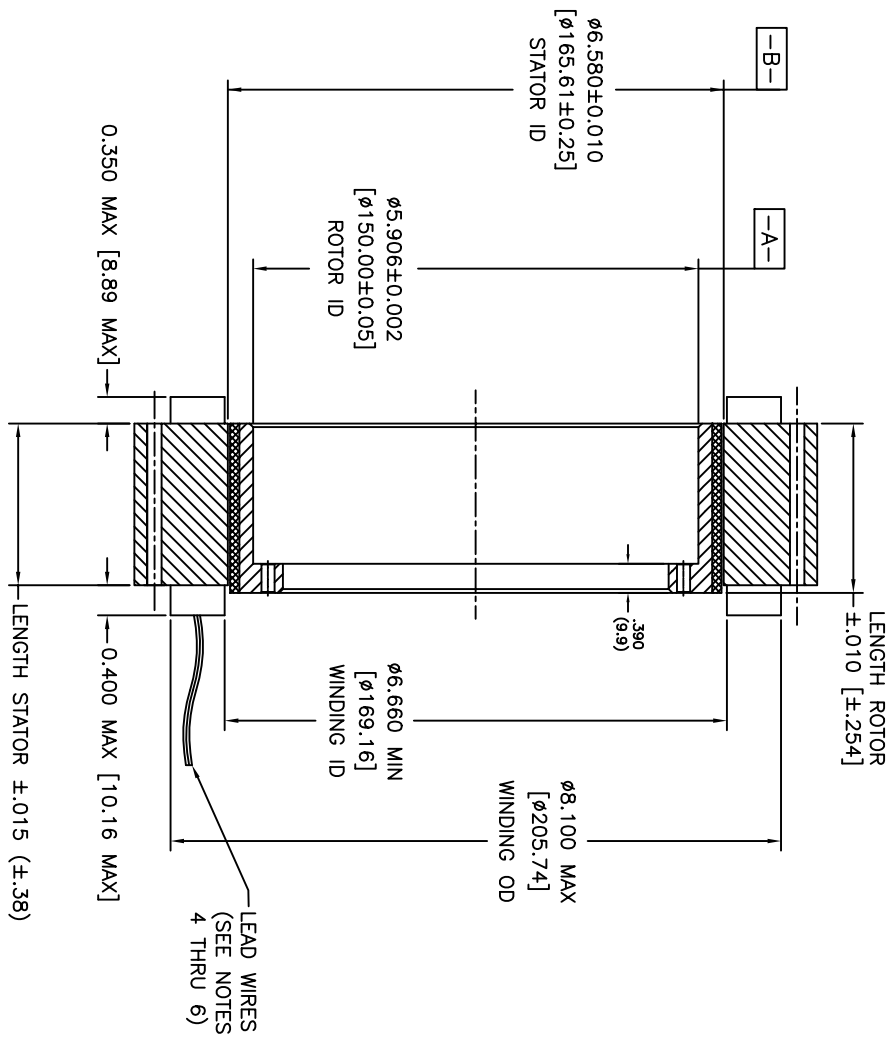
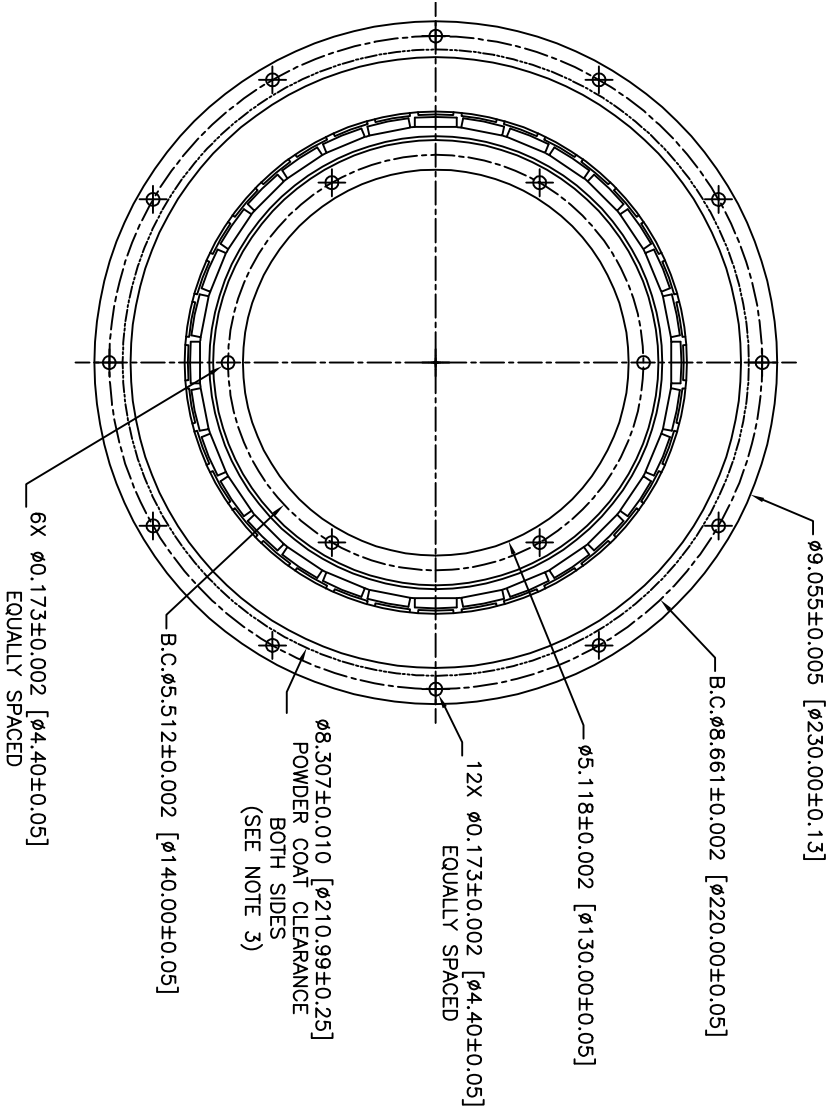

- NOTES:
- 1.) MOTOR SUPPLIED AS TWO SEPARATE COMPONENTS, ROTOR ASSEMBLY AND STATOR ASSEMBLY, CAUTION MUST BE TAKEN IN HANDLING, STRONG MAGNETIC FIELDS PRESENT.
 - 2.) DATUM DIAMETERS -A- AND -B- TO BE CONCENTRIC WITHIN 0.005 [0.127] WHEN MOUNTED.
 - 3.) CUSTOMER MOUNTING FLANGE FACE I.D. TO BE $\phi 8.347$ (212.01) MIN.
 - 4.) LEAD WIRE - TEFLON COATED PER MIL-W-16878 12" (304.8) MIN LENGTH
 - 5.) MOTOR 12 AWG RED (A), WHITE (B) AND BLACK (C)
 - 6.) SENSOR 22 AWG BLUE (+), BROWN (A), ORANGE (B), (YELLOW (C) AND GREEN (GRD)