

DS-58[20]-32

Absolute Position, Rotary Electric Encoder™



The **DS-58[20]** is a member of the DS series of Electric Encoders, based on Netzer Precision proprietary technology. These encoders offer many advantages, some unparalleled:

- Low profile (10 mm).
- Hollow, floating shaft.
- No bearings or other contacting elements.
- High precision.
- High tolerance to temperature, shock, moisture, EMI, RFI and magnetic fields.
- Analog or multiple digital interface options.
- Extremely low power options.

The **DS-58[20]** is suited to demanding application such as: aerospace, medical, instrumentation, automation, etc.

Mechanical - common to all types	
Allowable mounting eccentricity ⁽²⁾	±0.3 mm
Allowable rotor axial motion ⁽²⁾	±0.3 mm
Rotor inertia	800 gr · mm ²
Total weight	36 gr
Outer diameter / Inner diameter / Profile	58 / 20/ 10 mm
Material (stator, rotor)	Ultem™ polymer

Electrical - common to all types	
Supply voltage	5V ± 5% ⁽³⁾
Interconnection	250 mm Teflon-coated, flying AWG-32 leads

Environment - common to all types	
EMC ⁽⁴⁾	IEC 6100-6-2, IEC 6100-6-4
Operating temperature range	-55°C to +125°C ⁽⁵⁾ - analog output -55°C to +85°C ⁽⁵⁾ - digital output
Relative humidity	<98 % - non condensing
Shock endurance	IEC 60068-2-27 ; 100 g for 11 ms
Vibration endurance	IEC 60068-2-6 ; 20 g 10 – 2000 Hz

Performance - common to all types	
Electrical Cycles/Revolution – Fine/Coarse channels ⁽⁷⁾	32 / 3
Angular resolution (using 12 bit A/D conversion) ⁽⁸⁾	18 bits
Static error (with offset compensation) ⁽⁹⁾	< 20 mDeg
Maximum operational speed ⁽¹⁰⁾	1,500 rpm
Measurement range	Unlimited rotation

The holistic ⁽¹⁾ structure of the Electric Encoder™ provides generous mounting tolerance, thus obviating the need for internal ball bearings.

The lack of bearings and components such as flexible couplers, glass disc, light sources and detectors, along with very low power consumption makes the **DS-58[20]** encoder virtually failure free.

The internally shielded, DC operated Electric Encoder™ includes an electric field generator, a field receiver, a sinusoidal shaped dielectric rotor, and processing electronics.

The outputs signals of Electric Encoder™ are analog Sine / Cosine representing the rotation angle. The digital outputs are obtained by further processing which may be either internal or external to the encoder.

Outputs options		
Analog	Digital	
Sine/Cosine	SSi	AqB + Index

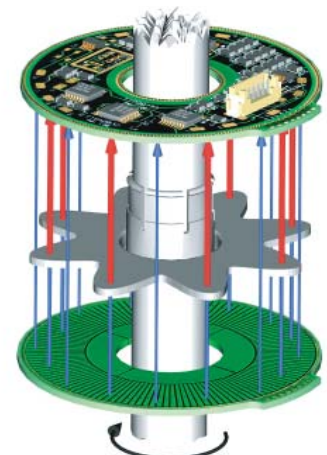

Output signal parameters	
Signal latency ⁽¹¹⁾	~250 µSec
Output code	Binary
Serial output SSi	Differential RS-422
Clock SSi	Differential RS-422
Monoflop time	25 µSec
Clock Frequency	0.5 ÷ 2.5 MHz
Maximum payload	19 bit

Electrical parameters	
Current consumption	~ 180 mA

The native outputs signals are analog Sine / Cosine representing the electric angle.

The digital output - Synchronous Serial Interface (SSi) transmits the absolute position data from the Electric Encoder™ in response to controller clock pulses. The encoder and controller are linked by clock and data differential signal lines.

Figure 1 illustrates the SSi timing diagram as implemented in the Electric Encoder . The digital SSi option also provides advanced calibration and monitoring options using the **NCP (Netzer Communication Protocol)** and factory supplied software tools.

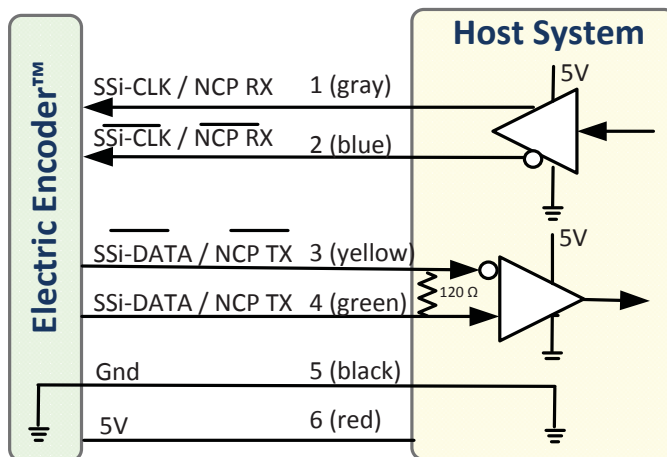

SSi - Wires color code			
#	Name	Color	Function
1	Clock +	Grey	SSi Clock
2	Clock -	Blue	
3	Data -	Yellow	SSi Data
4	Data +	Green	
5	GND	Black	Ground
6	+5V	Red	Power supply

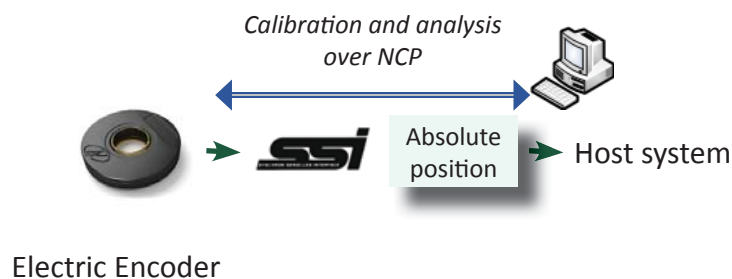

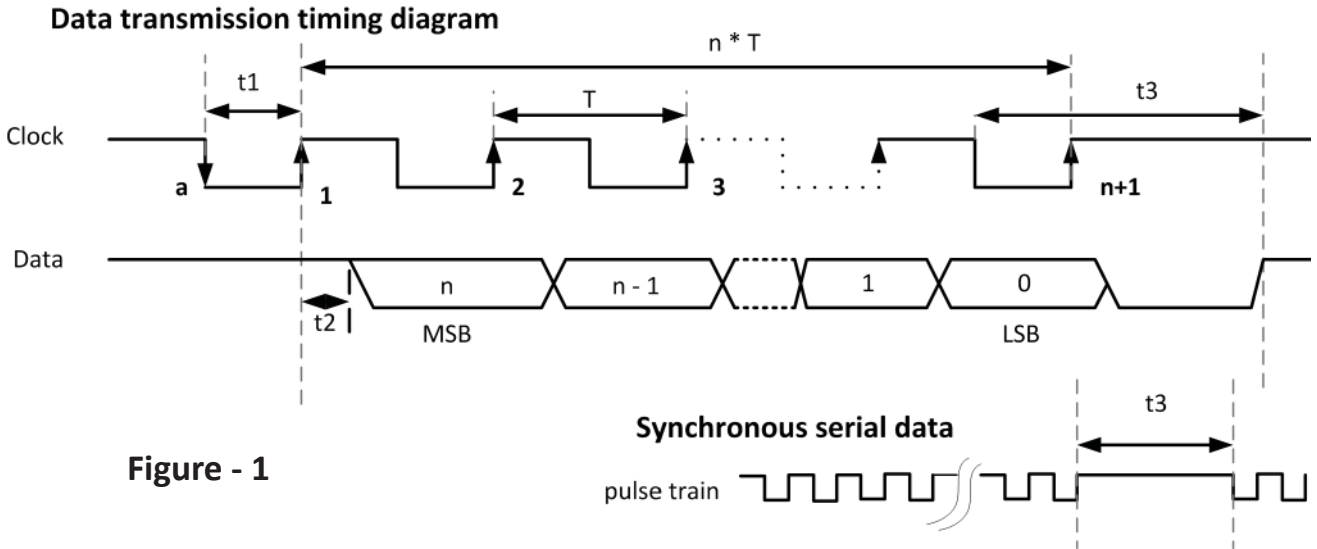

Figure - 1

n = total number of data bits.

T = clock period (sec) - user defined.

$1/T$ = clock frequency $0.5 \div 2.5$ MHz (user defined).

t_1 = minimum time required for the encoder to freeze data and preset the shift registers before receiving the first rising edge to prompt the MSB

t_2 = data transmission delay (increases with cable length)

t_3 = required delay to refresh position data between subsequent position reads.

Position calibration & signal analysis with SSI interface:

The Electric Encoder processing capabilities enable calibration, built-in tests and advanced setup, using factory supplied software tools, such as:

- A. Simple calibration procedure using the SSI Explorer (CAA, offsets and zero position setting).
- B. On-line aid for validating proper mechanical mounting.
- C. On-line NCP protocol for calibration and advanced analysis.

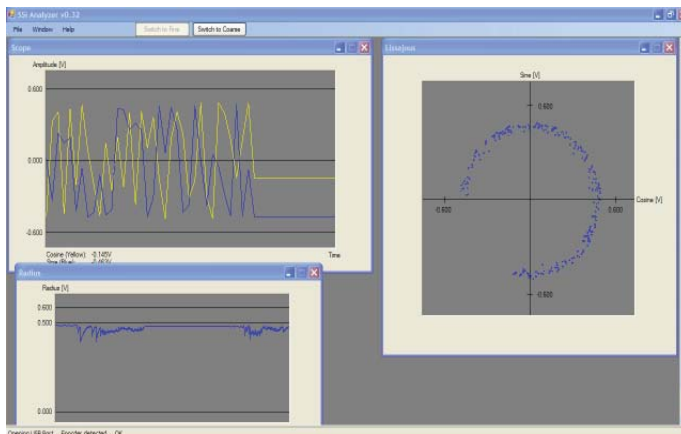
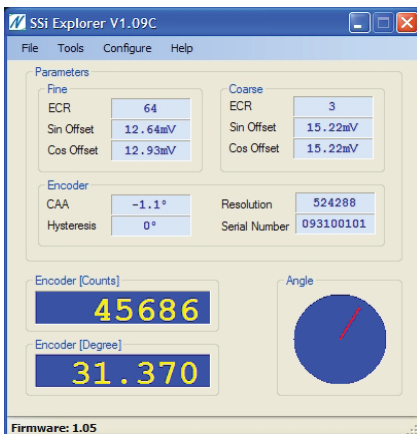

Output signal parameters

Signal latency ⁽¹¹⁾	250 μSec
Format	Differential RS-422
Phase relationship with CW shaft rotation (as seen from top)	A leads B
Index pulse width	½ A

Electrical parameters

Current consumption	~ 130 mA
---------------------	----------

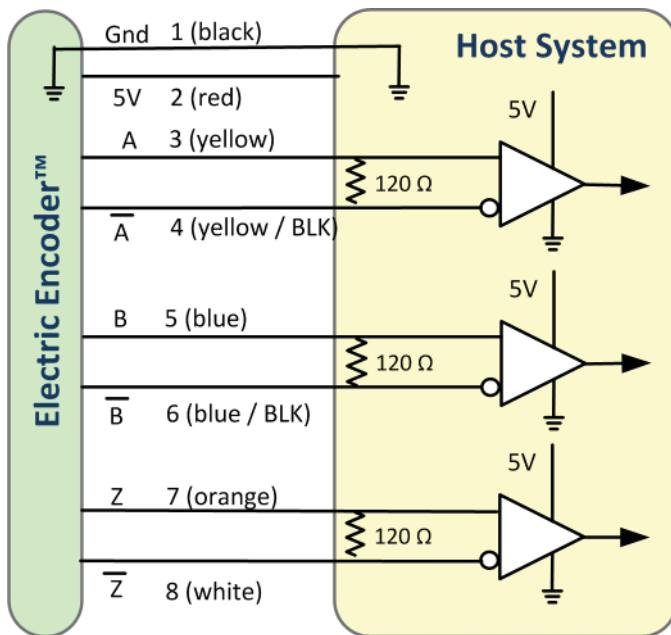
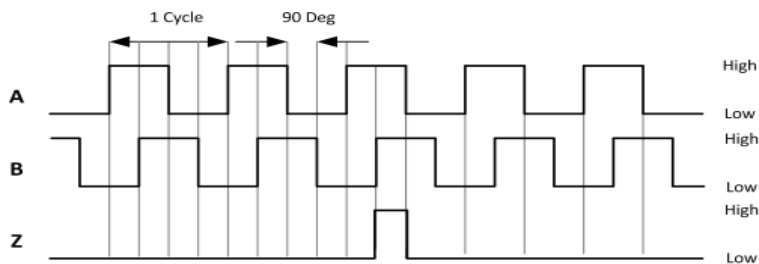

Wires color code			
#	Name	Color	Function
1	GND	Black	Ground
2	+5V	Red	Supply voltage
3	A+	Yellow	Quadrature outputs
4	A-	Yellow/Black	
5	B+	Blue	Quadrature outputs
6	B-	Blue / Black	
7	Z+	Orange	Index
8	Z-	White	
9	For factory use		
10			
11			
12			

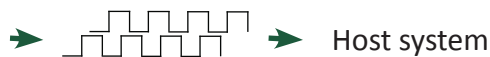

Electric Encoder

Output signal parameters

Signal latency ⁽¹¹⁾	250 μ Sec
Fine-mode output noise (DC to 1kHz) ⁽¹²⁾	100 μ V (p-p)
Fine-mode output amplitude ⁽¹³⁾	0.5V \pm 20%
Coarse-mode output amplitude	0.5V \pm 20%
Phase relationship (CW shaft rotation - seen from top)	Sine leads Cosine
Signal bandwidth	DC to 1 kHz

Electrical parameters

Output resistance	<1 Ω
Current consumption	\sim 10 mA ⁽¹⁴⁾

Coarse and Fine channels

The DS-58[20] has two operation modes: a Coarse-mode and a Fine-mode - equivalent to two separate encoders in a common housing. The modes are selectable by a logic C/F command; logic "0" (0V to +0.5V) selects the Coarse-mode, which has 3 Electrical Cycle/Revolution (EC/R) while logic "1" (+3V to +5V) selects the Fine-mode which has 32 EC/R. The switching time is less than 1 ms.

The Coarse-mode outputs need to be read only upon system initiation after which the encoder is permanently switched to the Fine mode. Coarse and Fine sine/cosine pairs are used to calculate the initial absolute position, from that point tracking the Fine-channel outputs provides the absolute mechanical rotation angle with the specified accuracy and resolution.

All output signals are referenced to an internally generated voltage Vr (\sim 2.25V)

Absolute Position calculation:

The analog Sine /Cosine outputs convey the electric angle of the Coarse or Fine signals. The absolute mechanical angle is computed by digitizing the analog signals and applying factory-supplied algorithms. Please refer to AN-02 and AN-03 .

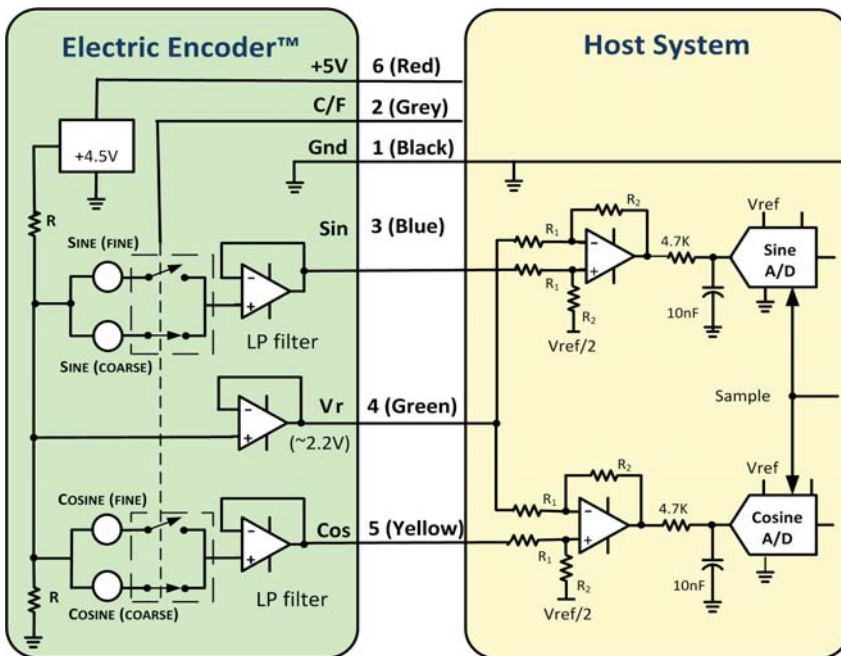

Wires color code			
#	Name	Color	Function
1	GND	Black	Ground
2	C/F	Grey	Coarse / Fine
3	Sine	Blue	Sine signal
4	Vr	Green	V reference
5	Cosine	Yellow	Cosine signal
6	+5V	Red	Power supply

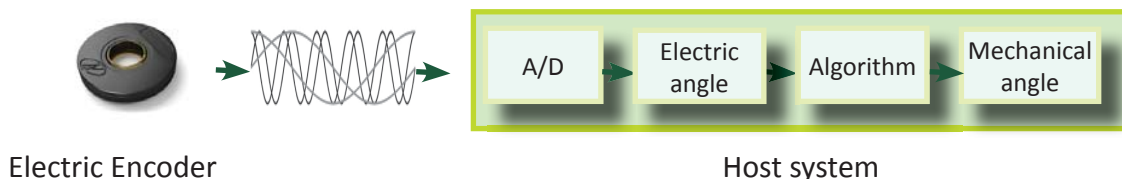

Notes

1. The output signals are generated by the whole area of the rotor - see AN-01.
2. Accuracy may degrade depending on mounting tolerances and the Sine/Cosine amplitudes may exceed the A/D conversion range -see AN-02
3. The encoder includes an internal 4.5V LDO voltage regulator.
4. Standard DS encoders are insensitive to ESD, stray magnetic and capacitive coupling from the host system current consumption. However it is advisable to allow a discharge path of no more than several tens of kΩ between the machine shaft and the electronic's ground, not leaving it electrically floating.
5. Consult factory.
6. For higher ingress protection the encoder should be mounted inside a sealed enclosure.
7. The number of electrical sine/cosine cycles generated in one mechanical rotation.
8. The angular resolution is determined by the ratio of the Fine - channel amplitude and the encoder inherent noise – see AN-05.
9. Not including dynamic error. For higher static accuracy consult factory.
10. Determined by the Fine-channel EC/Rs and the internal low pass filters, for higher rotation speed consult factory.
11. An inherent signal delay inversely proportional to the internal filter's cut-off frequency (1 kHz, 3rd order Bessel) and resulting in a dynamic error proportional to the rotation speed - see AN-05
12. For measuring the noise and validating the interconnection see AN-02.
13. With the rotor at its nominal axial position - see AN-02.
14. For a micro-power version with current consumption down to 50 μA @ 3V consult factory.

Resolution In bits	Steps /360°	mDeg /step	Arc-sec /step	mRad /step
12	4,096	87.8906	316.4063	1.534
13	8,192	43.9453	158.2031	0.767
14	16,384	21.9727	79.1016	0.3835
15	32,768	10.9863	39.5508	0.1917
16	65,536	5.4932	19.7754	0.0959
17	131,072	2.7466	9.8877	0.0479
18 (DS-58)	262,144	1.3733	4.9438	0.024
19	524,288	0.6866	2.4719	0.012
20	1,048,576	0.3433	1.236	0.006
21	2,097,152	0.1717	0.618	0.003
22	4,194,304	0.0858	0.309	0.0015

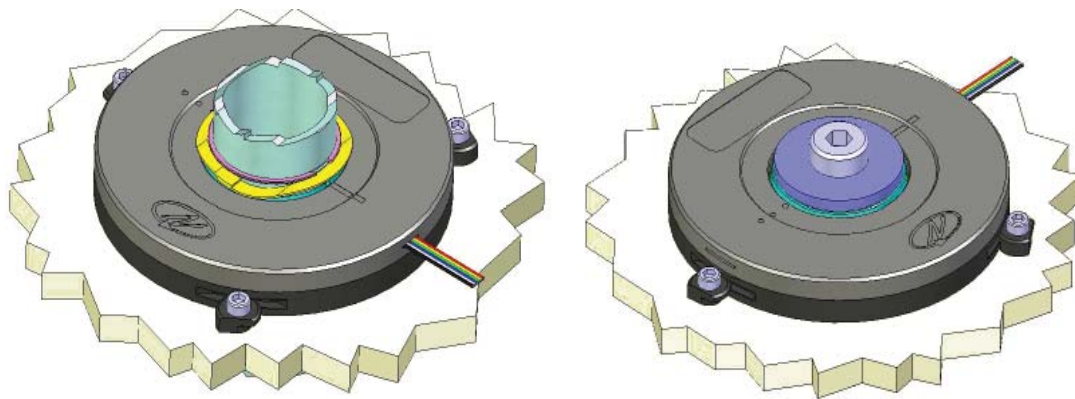

Related documents:

DS-58[20] Mechanical Installation Guide

Ordering

DS - 58 - 32 - SG - 02

DS
Product line

OD
EC/R

Outputs
0 - Analog: Sine/Cosine
A - Digital : AqB + index
S - Digital : SSI

Loose wires 250mm

Binary							
Resolution CPR	4,096	8,192	16,384	32,768	65,536	131,072	262,144
Bit	12	13	14	15	16	17	18
Code	A	B	C	D	E	F	G

Decimal							
Resolution CPR		8,000	16,000	32,000	64,000	128,000	256,000
Bit		13	14	15	16	17	18
Code		K	L	M	N	O	P

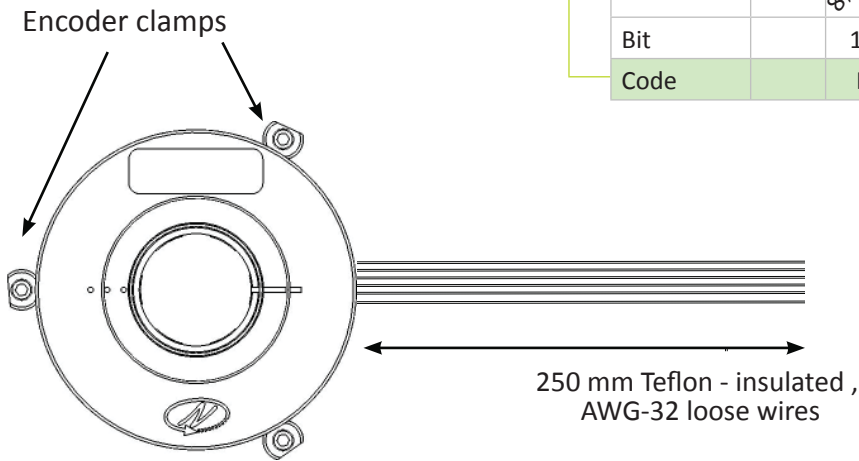

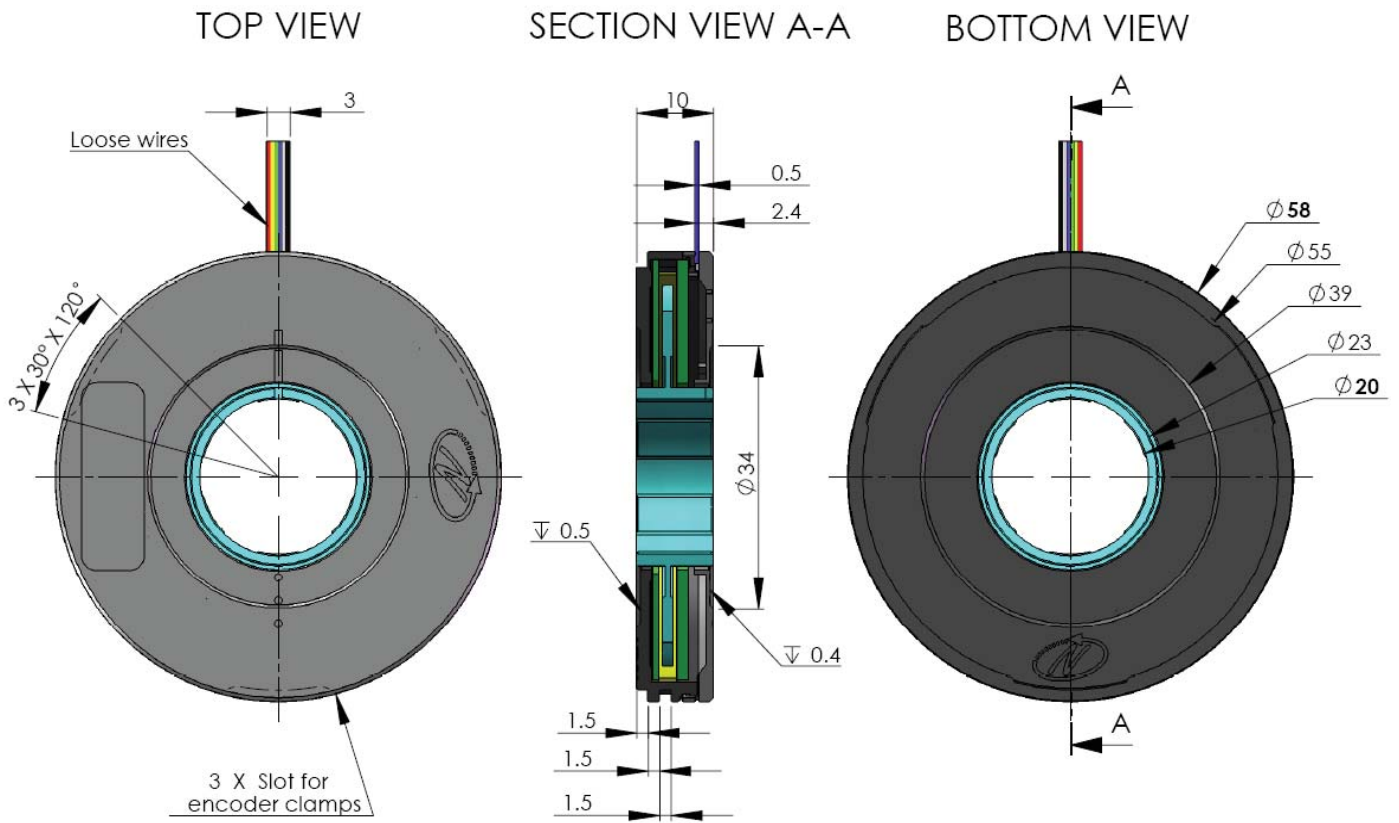

Demo Units:

Demo units with a rotating shaft are available with analog or digital outputs, USB based interface with the encoder and SSI explorer enable instant setup for demonstration, integration and analysis.

- CAT # : DKIT-DS-58-32-00-02 with analog output
- CAT # : DKIT-DS-58-32-AG-02 with AqB + Index output
- CAT # : DKIT-DS-58-32-SG-02 with SSI output