

FEATURES

- Micro-module mounts to user PC boards
- 72 Digital I/O
- 12 Analog Inputs
- 12 PWM Outputs
- 8 Dedicated Digital Inputs for
CAN Node Address
CAN Bit-rate
- 2 Outputs for CAN Status LED drive
- CAN & RS-232 Communications

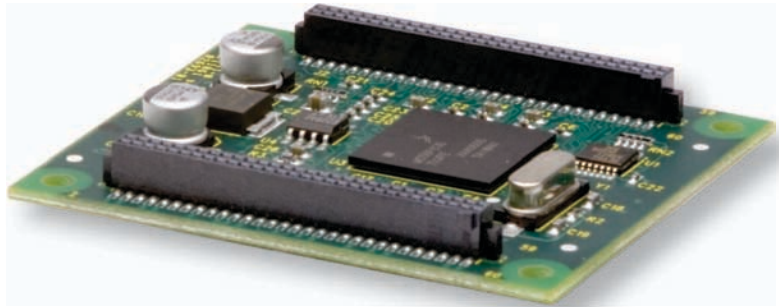

CANOPEN INTERFACE

- CAN V2.0b physical layer
- CANopen DS-301 V4.01 application layer

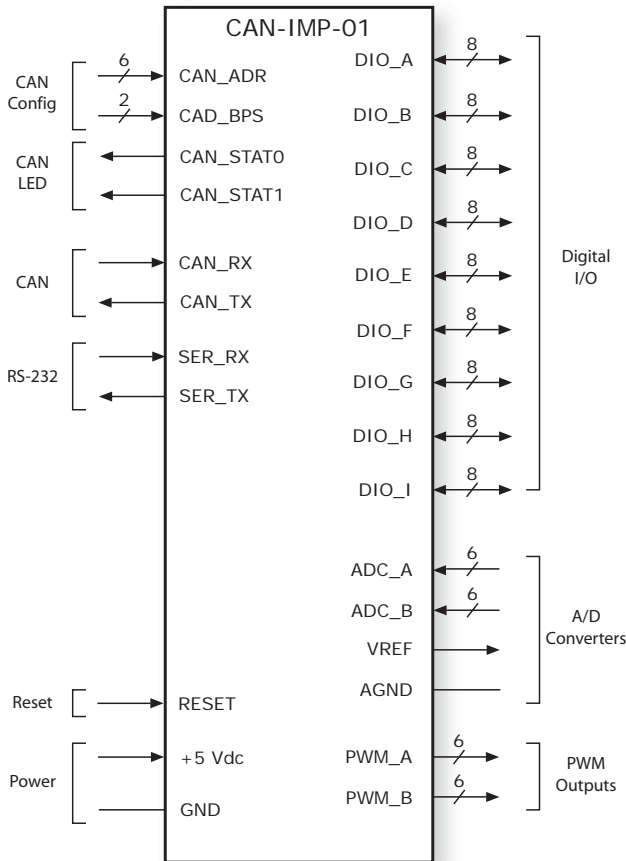

A PC board-mounting card for adding I/O to a CAN distributed control network. The CAN-IPM-01 combines configurable digital I/O points with dedicated analog and digital inputs and outputs to enhance distributed control networks using Copley's CANopen servo drives and stepper drivers.

Nine 8-bit ports are configurable as digital input or outputs. Twelve A/D ports convert 0-3 Vdc signals into 12-bit values. Twelve PWM outputs can be low-pass filtered to produce analog signals. Eight dedicated digital inputs set the CAN node address and bit-rate.

The DSP/microcontroller is the same type that is used in Copley's digital motion products and has the same software interface.

The card supports CAN bus bit-rates up to 1 Mbit/sec and RS-232 communications to 115,200 Baud.

Component count and cost are minimized by placing communication transceivers and I/O buffering off the CAN-IPM-01 where they can be selected and optimized as part of the user PC board design.

Driver software for Windows XP and 2000 is a free download from the Copley web-site. CMO (Copley Motion Objects) software, also available free on the web, works with Microsoft COM enabled computers for control of Copley's CANopen servo amplifiers and stepper drivers from high-level languages such as Visual Basic and LabView.

GENERAL SPECIFICATIONS

INPUT POWER

Supply voltage	+5 Vdc \pm 0.5 Vdc
Supply current	350 mAdc typical, 500 mAdc max

DIGITAL I/O

Number : function	72 : I/O in nine 8-bit ports: DIO_A~DIO_I are programmable by port as inputs or outputs
Input voltage LO	-0.3 < VIL < +0.8 Vdc
Input current LO	Pull-up resistor enabled: -200 μ A min, -100 μ A typ, -500 μ A max when VIN = 0 Vdc Pull-up resistor disabled: \pm 2.5 μ A max when VIN = 0 Vdc
Input voltage HI	+2.0 < VIH < +5.5 Vdc
Input voltage Max	+6.0 Vdc
Output voltage HI	2.4 Vdc @ -4 mA (DIO_A, DIO_E,H,I), 2.4 Vdc @ -8 mA (DIO_B,C,F,G,H)
Output voltage LO	0.4 Vdc @ 4 mA (DIO_A,H,I, 0.4 Vdc), 0.4 Vdc @ -8 mA (DIO_A,B,C,D,F,G,H)
External circuits required	Schmitt-trigger buffer/inverter with RC filters for digital inputs, buffer/inverters for digital outputs

CAN CONFIGURATION INPUTS

Number : function	8 : DIN0~DIN5 are for CAN node address, DIN6, DIN7 are for CAN bit-rate
Input voltage LO	-0.3 < VIL < +0.8 Vdc
Input current LO	Pull-up resistor enabled: -200 μ A min, -100 μ A typ, -500 μ A max when VIN = 0 Vdc Pull-up resistor disabled: \pm 2.5 μ A max when VIN = 0 Vdc
Input voltage HI	+2.0 < VIH < +5.5 Vdc
Input voltage Max	+6.0 Vdc
External circuits required	Schmitt-trigger buffer/inverter with RC filters for digital inputs, buffer/inverters for digital outputs

PWM OUTPUTS

Number	12 in two 6-bit ports
Output current/voltage	Source: -10 mA @ 2.4 Vdc, sink 12 mA @ 0.4 Vdc
Period (Frequency)	1 μ s ~8 ms (1 Mhz ~ 125 Hz)
Duty cycle	0~100%
External circuits required	RC low-pass filter with op-amp follower

ANALOG INPUTS

Number	12 A/D converter inputs in two 6-bit ports
Reference voltage	3.00 Vdc, supplied by voltage reference on the CAN-IPM-01 PC board
Reference current	10 mA max available from J2-13 for external circuits
Input voltage range	0.3 to 2.7 Vdc (0.1Vref to 0.9Vref) recommended, 0 to Vref Vdc max
External circuits required	Op-amp with output clamped to Vref max to scale and amplify user signals to A/D input voltage range

CAN STATUS LED OUTPUTS

Number	2
Output current HI	-4 mA @ 2.4 Vdc
Output current LO	4 mA @ 0.4 Vdc
External circuit required	Two buffer/inverters with sufficient current to drive red/green LED's

RS-232 PORT

Signals	RxD, TxD, Gnd
Mode	Full-duplex, serial communication port for amplifier setup and control, 9,600 to 115,200 baud
Protocol	Binary or ASCII formats
External circuit required	RS-232 transceiver

CAN PORT

Signals	CANH, CANL, Gnd
Format	CAN V2.0b physical layer for high-speed connections compliant
Data	CANopen Device Profile DSP-402
Address selection	Programmable to flash memory or determined by digital inputs
External circuit required	High-speed CAN transceiver

MECHANICAL & ENVIRONMENTAL

Size	3.83 x 2.47 x 1.29 in. (97.28 x 62.74 x 32.77 mm)
Weight	4.8 oz, 0.14 kg
Ambient temperature	0 to +45 °C operating, -40 to +85 °C storage
Humidity	0 to 95%, non-condensing
Contaminants	Pollution degree 2
Environment	IEC68-2: 1990
Cooling	Convection

OVERVIEW

The CAN-IPM-01 operates under *CiA DSP-401: CANopen Device Profile for Generic I/O Modules*.

It may be configured and controlled through both the serial interface, and through the CAN network interface. The serial interface uses the same protocol and commands as those used by the *Accelnet* and *Stepnet* families of digital servo drives. The list of parameters available to the I/O module are different from those used by the drives which operate under *CiA 402: CANopen device profile for drives and motion control*.

The CAN-IPM-01 hardware can be summarized as follows:

- 72 digital I/O in nine 8-bit ports, configurable by port as inputs or outputs (DIO_A ~ DIO_I)
- 8 digital inputs in one 8-bit port dedicated to the CAN address (DIN)
- 12 PWM outputs in two 6-bit ports (PWM_A, PWM_B)
- 12 analog inputs in two 6-bit ports plus a 3.00 Vdc reference output (ADC_A, ADC_B, VREF)
- 2 digital outputs for driving CAN status LED's (CAN_STAT0, CAN_STAT1)
- 2 I/O for CANopen communications (SER_RX, SER_TX)
- 2 I/O for RS-232 communications (CAN_RX, CAN_TX)
- 1 dedicated input for device reset (/MRESET)

The CAN-IPM-01 signals connect to the DSP and are low-voltage, low-current types that depend on user-supplied circuits for filtering, isolation, and voltage-scaling. Examples of such circuits will be shown along with functional diagrams of the various I/O functions.

POWER SUPPLY

Power for the CAN-IPM-01 must be 5.0 Vdc, $\pm 10\%$. Current requirements are 350 mA typical, 500 mA maximum. All circuits on the CAN-IPM-01 are non-isolated and will share a common electrical ground with circuits to which it connects.

CAN COMMUNICATIONS

CAN NODE ADDRESS (DIN_0~DIN_7)

There are eight dedicated digital inputs for the CAN node address and CAN bus speed. DIN_0 through DIN_5 select the CAN node address with DIN_0 being the LSB (Least Significant Bit). Address 0 is not allowed (it is reserved for the CAN bus master) so the resulting range of CAN addresses is 1~63 (decimal). Bus speed is selected via DIN_6 & DIN_7 with DIN_6 the LSB. The table below gives the possible combinations of bit-rate vs. input signals.

DIN_7	DIN_6	Rate (bit/s)
0	0	1 M
0	1	500 k
1	0	250 k
1	1	125 k

CAN STATUS LED'S (CAN_STAT0, CAN_STAT1)

Node-status LED's are driven from two dedicated outputs as shown below. The colors and output levels in the chart apply when used in a circuit with inverting buffers that can sink/source the LED currents. This circuit is on the CAN-IPM-01 PC board. The CAN_STATx signals are also brought out to the module connectors for control of external LED's. If this is done, the signals should be buffered as shown.

CAN_STAT1	CAN_STAT0	LED
0	0	Off
0	1	Green
1	0	Red
1	1	Off

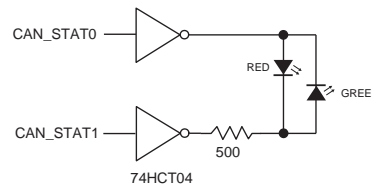

CAN BUS SIGNALS (CAN_TX, CAN_RX)

CAN bus signals CAN_RX and CAN_TX are designed to work with a CAN transceiver device that is on the user PC board. The TJA1050 is a typical device and the diagram below shows the connections.

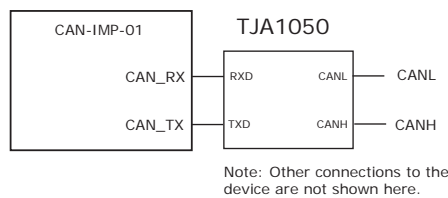

[Click here for more information on the TJA1050 High-Speed CAN Transceiver](#)

RESET INPUT

The /MRESET input connects to a Supply Voltage Supervisor that has a threshold voltage of 2.93 Vdc. If VDD is <2.93 Vdc, the /RESET signal to the DSP will be asserted. When VDD is >3.12 Vdc, the /RESET signal will be removed after a 200 ms delay. Grounding the /MRESET input will hold the DSP in a reset state. When the /RESET input is HI the DSP will operate as long as VDD is >3.12 Vdc. The /MRESET input has an internal pull-up resistor and will default to a HI level.

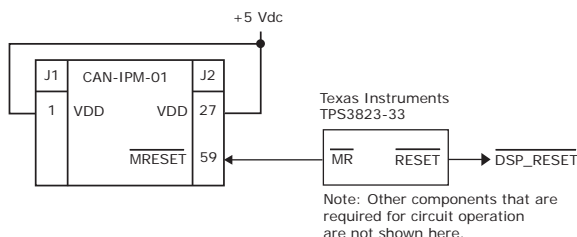

[Click here for more info on the TPS3823-33 Supply Voltage Supervisor](#)

RS-232 COMMUNICATIONS

The CAN-IPM-01 supports full-duplex serial communications using the RS-232 protocol. An external RS-232 transmitter/receiver is required in order to convert the TTL signals of the CAN-IPM-01 into higher-voltage, RS-232 compliant signals. A typical device is the Intersil HIN202. These operate from +5V and generate the required voltages from on-chip charge pumps and external capacitors. The figure below shows the connections between the CAN-IPM-01 and the Intersil HIN202 RS-232 Transmitter/Receiver.

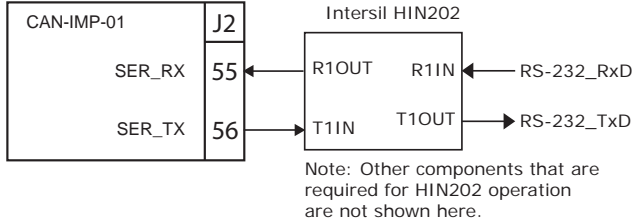

[Click here for more info on the Intersil HIN202](#)

DIGITAL I/O (DIO_A~DIO_I)

The CAN-IPM-01 has 80 digital I/O pins arranged in ten ports of eight pins each. Nine ports (DIO_A-DIO_I) are configurable as inputs or outputs. The tenth port (DIO_J) is input-only. Within a port there are additional options that are selectable on a per-pin basis.

Input port selections:

- Invert
- Pull-up resistor
- De-bounce time (ms)
- Enable Fault

Output port selections:

- Invert
- Power up state HI
- Open-drain

	V_high	V_low
Input	2.0V min	0.8V max
Output	2.4V min @ -4 mA	0.4V max @ 4mA

ANALOG INPUTS

There are 12 A/D converters in two six-input banks. All have 12 bit resolution with an input voltage range of 0 to 3.00 Vdc which is supplied by an on-board precision reference. Absolute maximum input voltage is 4.0 V, and for best results inputs should be scaled from 10% to 90% of Vref (3.00 Vdc). Circuits designs using op-amps powered from 3.3 Vdc not only limit the A/D input voltage to a safe level, but can incorporate anti-aliasing filters and DC offsetting so that bipolar voltages can be offset to Vref/2 with the 10% and 90% (0.3 and 2.7 Vdc) points used and negative and positive full-scale. This allows for some small headroom about the min/max voltages. Unused inputs should be connected to AGND. The reference voltage VREF is brought out to J2 for user by external circuits.

ANALOG OUTPUTS

These are digital PWM outputs which, when low-pass filtered, can produce analog voltages. The repetition rate and duty cycle of the outputs are programmable.

PC BOARD MOUNTING AND DIMENSIONS

These are .050" pitch female headers and are available in through-hole or SMT configurations.

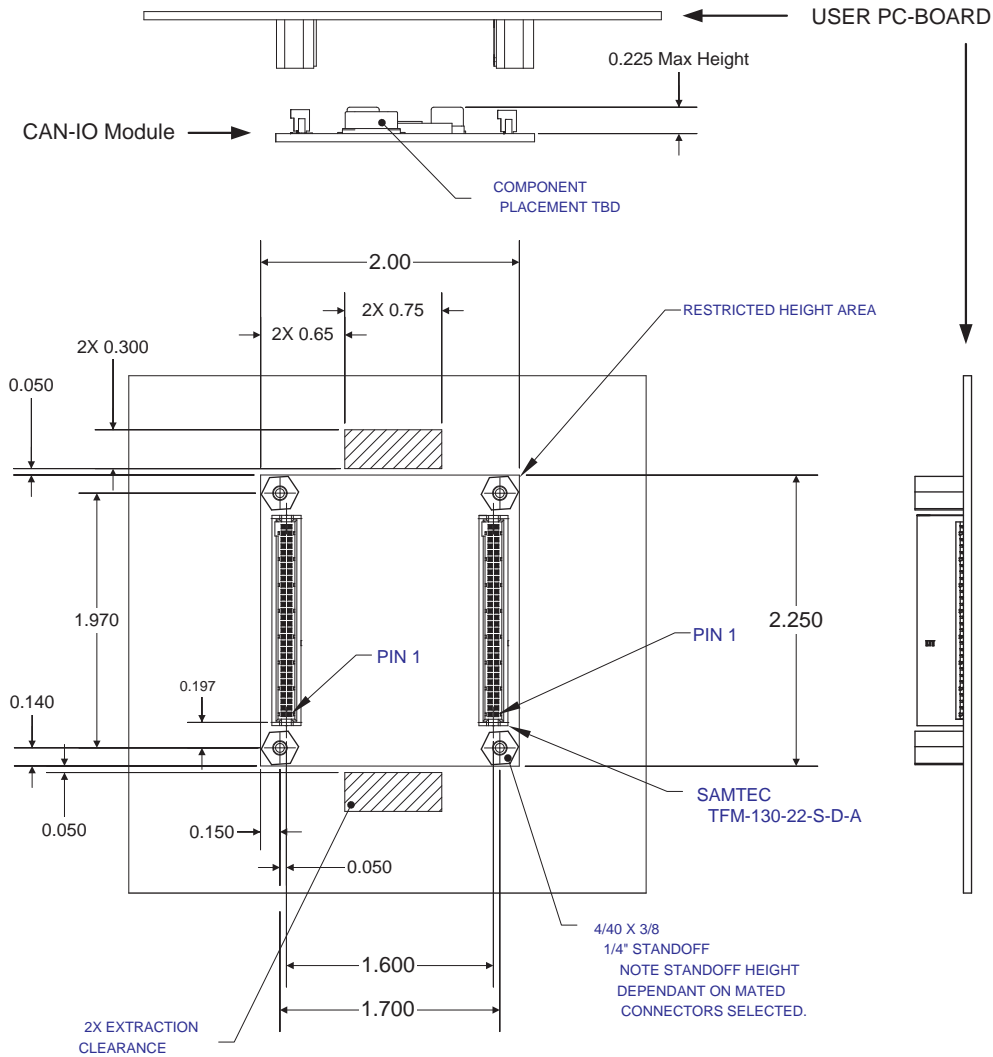

TOP VIEW COMPONENT PLACEMENT

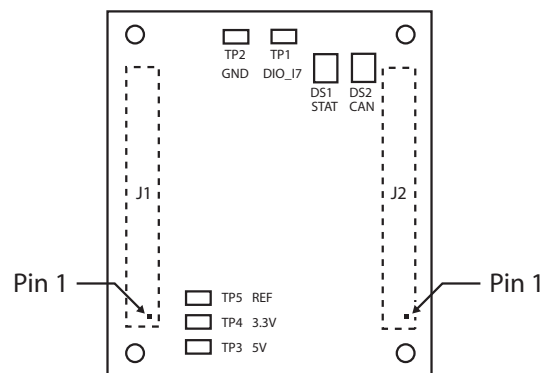

PC BOARD MATING CONNECTORS

These are .050" pitch female headers and are available in through-hole or SMT configurations. The SAMTEC TFM-130-22-S-D-A gives a "mated height" of 0.39 in which is 0.015 in higher than a 3/8" standoff (shown in the drawing on p. 4). A flat #4 or M3 flat washer is .025" thick, so adding this under the standoffs would make them 0.400 high.

CONNECTOR PINS & SIGNALS

Signal	J1 Pin		Signal
+5VI	1	2	GND
/WR	3	4	/RD
DIO_A0	5	6	DIO_A1
DIO_A2	7	8	DIO_A3
DIO_A4	9	10	DIO_A5
DIO_A6	11	12	DIO_A7
DIO_B0	13	14	DIO_B1
DIO_B2	15	16	DIO_B3
DIO_B4	17	18	DIO_B5
DIO_B6	19	20	DIO_B7
DIO_C0	21	22	DIO_C1
DIO_C2	23	24	DIO_C3
DIO_C4	25	26	DIO_C5
DIO_C6	27	28	DIO_C7
DIO_D0	29	30	DIO_D1
DIO_D2	31	32	DIO_D3
DIO_D4	33	34	DIO_D5
DIO_D6	35	36	DIO_D7
DIO_E0	37	38	DIO_E1
DIO_E2	39	40	DIO_E3
DIO_E4	41	42	DIO_E5
DIO_E6	43	44	DIO_E7
DIO_F0	45	46	DIO_F1
DIO_F2	47	48	DIO_F3
DIO_F4	49	50	DIO_F5
DIO_F6	51	52	DIO_F7
DIO_G0	53	54	DIO_G1
DIO_G2	55	56	DIO_G3
DIO_G4	57	58	DIO_G5
DIO_G6	59	60	DIO_G7

Signal	J2 Pin		Signal
PWM_A0	1	2	PWM_A1
PWM_A2	3	4	PWM_A3
PWM_A4	5	6	PWM_A5
PWM_B0	7	8	PWM_B1
PWM_B2	9	10	PWM_B3
PWM_B4	11	12	PWM_B5
VREF	13	14	AGND
ADC_A0	15	16	ADC_A1
ADC_A2	17	18	ADC_A3
ADC_A4	19	20	ADC_A5
ADC_B0	21	22	ADC_B1
ADC_B2	23	24	ADC_B3
ADC_B4	25	26	ADC_B5
+5VI	27	28	GND
DIO_H0	29	30	DIO_H1
DIO_H2	31	32	DIO_H3
DIO_H4	33	34	DIO_H5
DIO_H6	35	36	DIO_H7
DIO_I0	37	38	DIO_I1
DIO_I2	39	40	DIO_I3
DIO_I4	41	42	DIO_I5
DIO_I6	43	44	DIO_I7
DIN_0	45	46	DIN_1
DIN_2	47	48	DIN_3
DIN_4	49	50	DIN_5
DIN_6	51	52	DIN_7
CAN_STAT0	53	54	CAN_STAT1
SER_RX	55	56	SER_TX
CAN_RX	57	58	CAN_TX
/MRESET	59	60	GND

ORDERING GUIDE

PART NUMBER	DESCRIPTION
CAN-IPM-01	CAN Input/Output Processor

Driver software for Windows XT or 2000, firmware, CAN-monitor, and CME 2 can be downloaded from the Copley web-site. Contact the factory for drivers for Linux