

LINEAR SPECIFICATONS:

LINEAR STROKE: 10.0 +1/-0 mm
 PEAK FORCE: 1.5N @ 24Vdc(1.5A)
 FORCE CONSTANT: 1.0 N/A
 ENCODER RESOLUTION: 1 μm
 ENCODER REPEATABILITY: 2 ±μm
 MOVING MASS: 10 grams
 TOTAL MASS: 0.080 kg
 OPERATING TEMPERATURE: 0°C TO 65°C

ALL DIMENSIONS ARE IN mm

REVISION HISTORY				
REV	DATE	ECN	DESCRIPTION	APPROVED
E	12/3/2008			ORAMAS

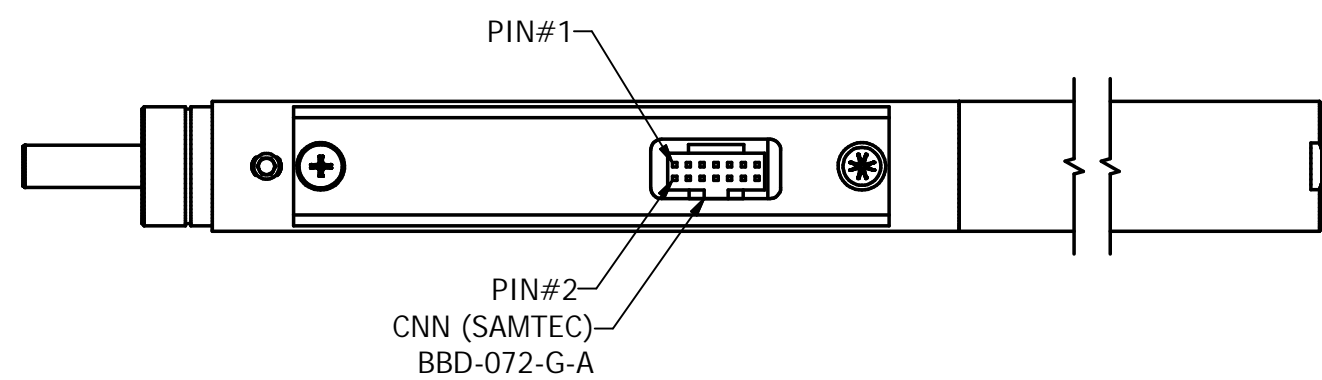
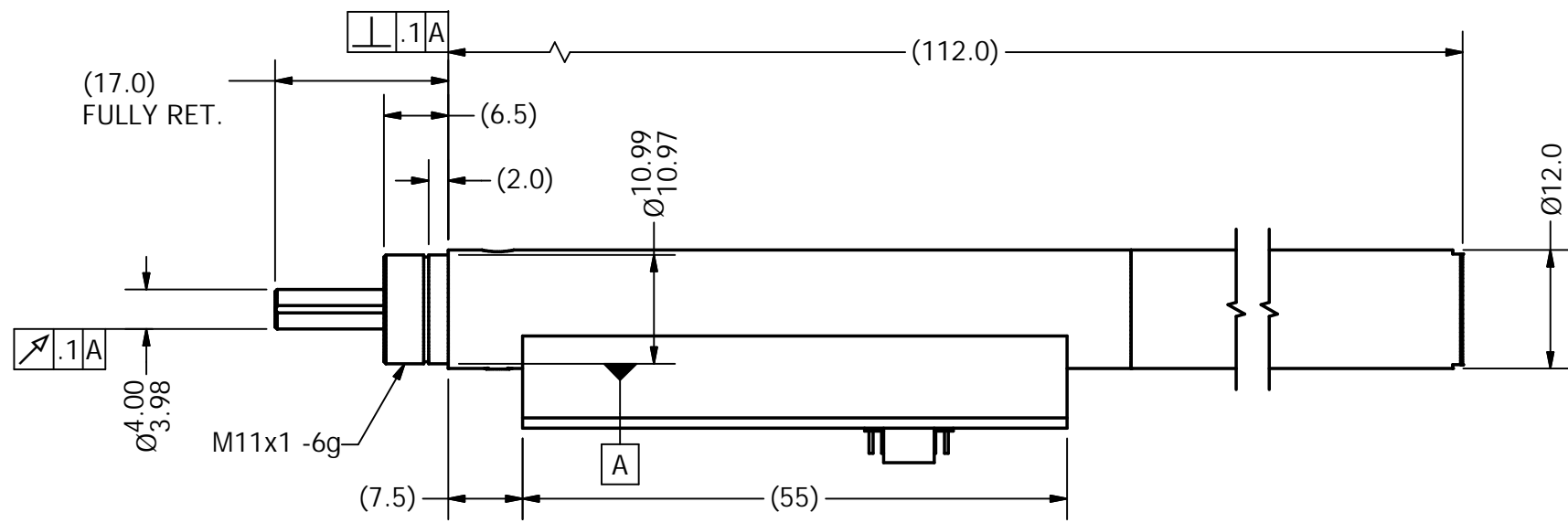
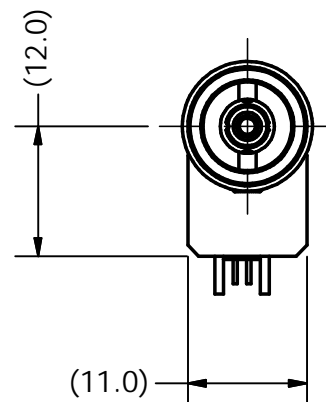

No	Details
1	+5V
2	GND
3	A-
4	A+
5	B-
6	B+
7	I-
8	I+
9	CL-
10	CL+
11	CL-
12	CL+
13	CL-
14	CL+

TOLERANCES ARE: X. ± 0.50 X.X ± 0.1 X.XX ± 0.05 X.XXX ± ANGULARITY ± 0.1° CONCENTRIC ± 0.01 ROUNDNESS ± 0.05 EDGE BREAK 0.02 MAX CHAMFER 0.03 MAX FILE NAME: CAL12-010-5-CNN_D.idw	MATERIAL:	SMAC		REF. NUMBER CA12		
	HEAT TREATMENT:			DESIGNED BY: toanvu	DATE: 1/28/2009	CHECKED BY:
	MACHINE FINISH: 3.2/	EXCEPT NOTED	PART NAME: CAL12-010-51			SHEET NUMBER: 1 OF 1
	PROTECTIVE FINISH: NONE	SCALE: NONE DO NOT SCALE DWG	DWG SIZE: B	APPROVED BY:	DATE:	REVISION: E
	SPEC. NUMBER: NONE				PART NUMBER: CAL12-010	