

FEATURES

- **CE Compliance to 89/336/EEC**
- **Underwriters Laboratories Recognized Component to UL 508C**
- **Only one potentiometer!**
- **Component socket configures amp completely**
- **Flexibility! Internal 40-pin socket configures amp with no soldering**
- **Separate current limits: Continuous, peak, and peak-time**
- **No integrator windup when disabled**
- **Fault protections: Short-circuits from output to output, output to gnd Over/under voltage Over temperature Self-reset or latch-off modes**
- **3kHz Bandwidth**
- **Wide load inductance range: 0.2-40 mH.**
- **Surface mount technology construction, lower part count.**

APPLICATIONS

- **X-Y stages**
- **Robotics**
- **Automated assembly machinery**
- **Magnetic bearings**

THE OEM ADVANTAGE

- **Conservative design for high MTBF**
- **No soldering required to change header parts.**
- **Custom configurations available (contact factory) No-pots, custom headers**

MODEL	POWER	I-CONT	I-PEAK
4122CE	+22 to +90 VDC	10	20
4212CE	+22 to +125 VDC	6	12



PRODUCT DESCRIPTION

These amplifiers are variants of the popular 4xx2 series DC brush motor amplifiers that feature compliance with European Community directive 89/336/EEC, also known as "CE".

Models 4122CE and 4212CE are third-generation amplifiers for dc brush motors from Copley Controls Corp. Built using surface-mount technology, these amplifiers offer plug and play operation in a very small package. All models take industry standard $\pm 10V$ control signals as input, and operate motors in torque mode, or velocity mode using analog brush tachometers.

Velocity loops using brush-tachometer feedback are used for open-loop speed controls, or in position control loops requiring improved regulation at low speeds.

Model 4122CE operates from +22 to +90VDC unregulated power supplies, and outputs 10A continuous, 20A peak.

Model 4212CE operates from +22 to +125VDC power supplies, and outputs 6A continuous, and 12A peak.

The active logic-level of the amplifier Enable input is jumper selectable to GND or +5V to interface with different control cards. /Pos and /Neg enable inputs remain ground active for fail-safe operation.

Mosfet H-bridge output stage delivers power in four-quadrants for bi-directional acceleration and deceleration of motors.

An internal solderless socket holds 17 components that configure the various gain and current limit settings to customize the amplifiers for a wide range of loads and applications.

Header components permit compensation over a wide range of load inductances to maximize bandwidth with different motors.

Individual peak and continuous current limits allow high acceleration without sacrificing protection against continuous overloads. Peak current time limit is settable to match amplifier to motor thermal or commutation limits.

All models are protected against output short circuits (output to output and output to ground) and heatplate overtemperature.

With the /Reset input open, output shorts or heatplate overtemperature will latch off the amplifier until power is cycled off & on, or until the /Reset input is grounded.

For self-reset from such conditions, wire /Reset to ground and the amplifier will reset every 200ms.

A bicolor led speeds diagnostics during set-up, or for fault isolation after the unit is in service.

Models 4122CE, 4212CE

DC Brush Servo Amplifiers

TECHNICAL SPECIFICATIONS

Test conditions: 25°C ambient, Load = 200µH. in series with 1 Ω., +HV = maximum normal value

MODEL	4122CE	4212CE
OUTPUT POWER		
Peak power	±20A @ ±80V	±12A @ ±120V
Peak time	0.5 sec unipolar from 0A, 1 secs. after polarity reversal	
Continuous power	±10A @ ±80V	±6A @ ±120V
OUTPUT VOLTAGE		
	$\pm V_{out} = \pm HV * (0.97) - (R_o) * (I_o)$	
	$R_o = 0.2$	$R_o = 0.1$
LOAD INDUCTANCE		
	Selectable with components on header socket: 200 µH to 40mH	
BANDWIDTH		
Current mode:	3kHz with 200µH load at maximum supply voltage, varies with load inductance and RH15, CH16 & CH17 values	
PWM SWITCHING FREQUENCY		
	25kHz	
REFERENCE INPUT		
	Differential, 94K between inputs, ±20V maximum	
GAINS		
Input differential amplifier	1:1 (Volt / Volt)	
PWM transconductance stage	I _{peak} / 6V (I _{peak} = peak rated output current; 6V measured at Current Ref J2-9)	
LOGIC INPUTS		
Input voltage range	0 to +24V	
Logic threshold voltage (LO to HI transition)	2.5V (Schmitt trigger inputs with hysteresis)	
/Enable (Internal jumper JP1 reverses logic)	LO enables amplifier, HI disables (Default function with JP-1 on pins 2-3. For +5V enable and GND inhibit, move JP1 to pins 1-2)	
Time delay on Enable	0.9 ms after Enable true to amplifier ON, <1ms to disable	
/POS enable, /NEG enable	Gnd enables positive or negative output currents. +5V or open inhibits (<1ms delay) (Setting of JP-1 has no effect on ground-active level of /POS and /NEG enable inputs)	
/Reset	LO resets latching fault condition, ground for self-reset every 200 ms.	
Input resistance	10K pull-up to +5V, R-C filters to internal logic	
POTENTIOMETER		
Balance	Use to set output current or rpm to zero. RH1 = 10 MΩ for Balance function, RH1 = 100kΩ for Test function	
LOGIC OUTPUT		
+Fault (/Normal)	HI = Overtemp OR output short OR power NOT-OK, OR NOT-Enabled; LO = Operating normally AND enabled	
HI output voltage	+5V (33kΩ pullup resistor to +5V) +50V maximum	
LO output voltage	<0.5V typical, 1.25V @ 250mA max, R _o = 5Ω (mosfet on resistance)	
INDICATOR (LED)		
Normal	Green: ON = Amplifier Enabled AND Normal (power OK, no output shorts, no overtemp) Red = Fault (NOT Normal, see +Fault output above)	
ANALOG MONITOR OUTPUTS		
Current Ref (current demand signal to pwm stage)	±6V @ demands ±I _{peak}	
Current Monitor (motor or load current)	±6V @ ±I _{peak} (1kΩ, 33nF R-C filter)	
DC POWER OUTPUTS		
	±15VDC each output in series with 10kΩ	
PROTECTIVE FEATURES (Note 1)		
Output short circuit (output to output, output to ground)	Latches unit OFF	
Overtemperature	Latches unit OFF at 70°C on heatplate	
Undervoltage shutdown @	<20V	<20V
Overvoltage shutdown @	>92VDC	>129VDC
POWER REQUIREMENTS		
DC power (+HV) Transformer isolated from power mains	+22 to +90VDC	+22 to +125VDC
Watts minimum	2.5W	2.7W
Watts @ I _{cont}	25W	41W
THERMAL REQUIREMENTS		
Storage temperature range: -30 to +85°C; operating temperature range: 0 to 70°C baseplate temperature		
Notes: 1. Heatsink optional (add "H" to model number) 2. Fan = forced air over unit @ 400 linear feet/minute		
MECHANICAL		
Amplifier case size	4.3 x 3.0 x 1.0 in. (109 x 76.2 x 25.4 mm.)	
Heatsink	Adds 1.50 in. (38.1 mm) to amplifier 1.0 in. dimension. Same length as amp.	
Weight	0.43 lb (0.2 kg.) for amplifier alone; heatsink adds 0.78 lb. (0.35 kg)	
CONNECTORS		
J1 (Power & motor): 5 position compression-connector; Phoenix MKDS 3; maximum wire gauge AWG 12 (4 mm ² solid or 2.5 mm ² stranded) wire.		
J2 (Signal): 16-position 0.1" centers housing (Molex: 22-01-		

FUNCTIONAL DIAGRAM

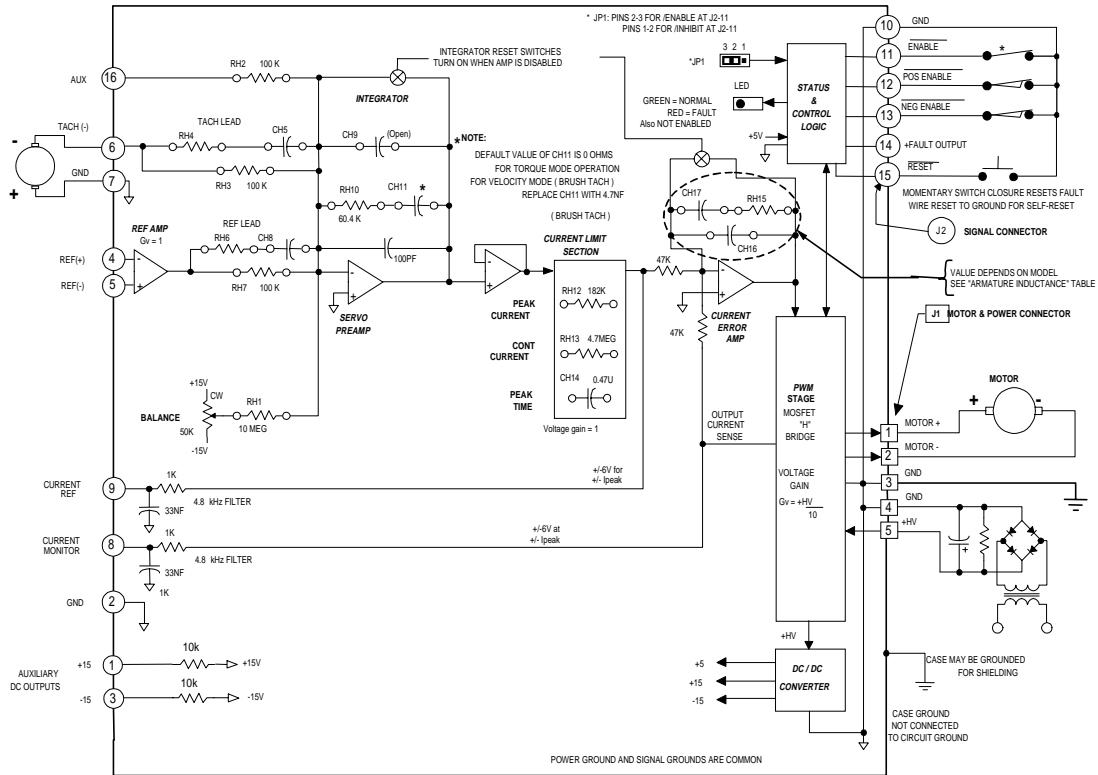

TYPICAL CONNECTIONS

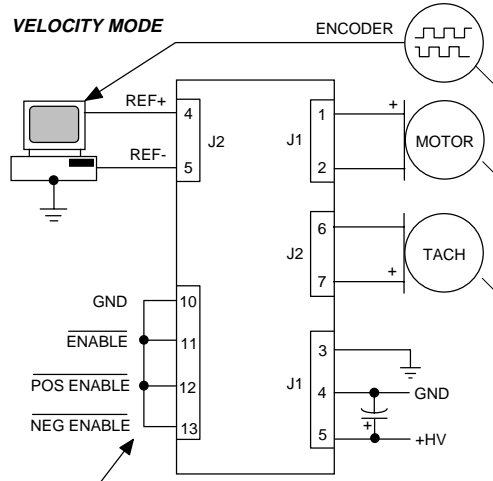
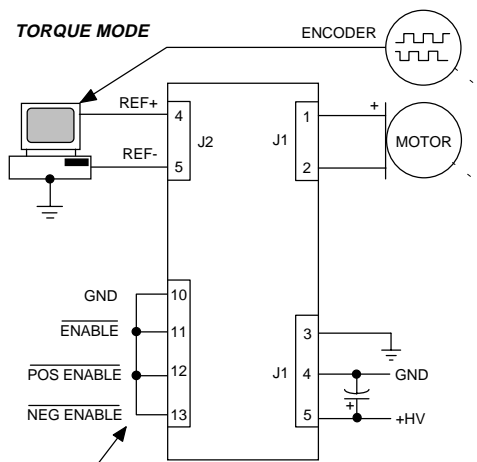

Notes

- All amplifier grounds are common (J1-3, J1-4, J2-2, J2-7, and J2-10). Amplifier grounds are isolated from case & heatplate.
- Jumper JP1 default position is on pins 2-3 for ground active /Enable input (J2-11). For /Inhibit function at J2-11 (+5V enables), move JP1 to pins 1-2
- For best noise immunity, use twisted shielded pair cable for reference and tachometer inputs. Twist motor and power cables and shield to reduce radiated electrical noise from pwm outputs.

CONNECTORS AND PINOUTS

J1: MOTOR & POWER CONNECTIONS

Pin	Signal	Remarks
1	Motor (+)	Amplifier output to motor (+) winding
2	Motor (-)	Amplifier output to motor (-) winding
3	GND	Power supply return. Connect to system ground at this pin.
4	GND	Power supply return. Connect to system ground at this pin.
5	+HV	+HV DC power supply input

J2: AMPLIFIER BOARD CONNECTIONS

Pin	Signal	Remarks
1	+15V	+15V in series with 10k Ω
2	Gnd	Signal ground
3	-15V	-15V in series with 10k Ω
4	Ref (+)	Differential input positive terminal for Reference voltage
5	Ref (-)	Differential input negative terminal for Reference voltage
6	Tach (-)	Negative terminal of brush tachometer
7	Gnd / Tach (+)	Signal ground, or positive terminal of brush tachometer
8	Curr Mon	Output current monitor: $\pm 6V$ output at \pm peak output current
9	Curr Ref	Current demand signal to PWM stage: $\pm 6V$ demands \pm peak current
10	Gnd	Signal ground
11	/Enable	Amplifier enable input: enables or inhibits PWM switching at outputs Default: Gnd enables amplifier, open or +5V inhibits (JP1 @ 2-3) For controllers that output +5V to enable amplifier, move internal jumper JP1 to pins 1-2 (Gnd will inhibit, +5V or open will enable)
12	/Pos Enab	Gnd to enable output current in one polarity, open or +5V to inhibit Typically used with grounded, normally closed limit switches.
13	/Neg Enab	Gnd to enable output current in opposite polarity, open or +5V to inhibit. Typically used with grounded, normally closed limit switches.
14	/Normal	Current-sinking when amplifier enabled and operating normally. Goes to +5V when amplifier disabled or fault condition exists.
15	/Reset	Ground to reset overtemp or output short circuit latching faults. For automatic reset of faults every 200mS, ground permanently.
16	Aux	Single-ended auxiliary input.

BALANCE POTENTIOMETER

Default position: centered. Functions to bring output current (in torque mode) or output velocity (in tachometer mode) to zero with reference input voltage at zero, or control system output at zero. Normal range is $\pm 1\%$ of full scale with 10Meg resistor in header location RH1. To use the pot as a wide range set-point adjustment, install a 150k Ω resistor at RH1. Now, full CW or CCW will have the effect of a $\pm 10V$ signal at the reference inputs.

STATUS LED

Dual color, red/green.

Color	+HV	/Enable	Short	Overtemp
Green	Normal	Active	None	Normal
Red	Too low or too high	X	X	X
	X	Inhibited	X	X
	X	X	Output short	X
	X	X	X	Too hot
Note	1, 5	2, 5	3, 5	4, 5

Notes:

- +HV normal >20V and <92V for model 4122CE, >20V and <129V for model 4212CE
- /Enable is ground-active for JP1 on pins 2-3 (default). To reverse function, switch JP1 to pins 1-2.
- Shorts detected by overcurrent circuit are between outputs, or from outputs to ground.
- Overtemperature faults occur when heatplate temperature is >70 $^{\circ}C$
- +HV and /Enable cause momentary amplifier shutdown, operation is restored when +HV is within normal limits and /Enable input is active. Output shorts, and overtemperature faults *latch-off* amplifier. Thus amplifier will remain off until power is cycled on/off, or /Reset input is grounded momentarily. If /Reset input is wired to ground, output short and overtemperature faults will self-reset every 200ms.

COMPONENT HEADER

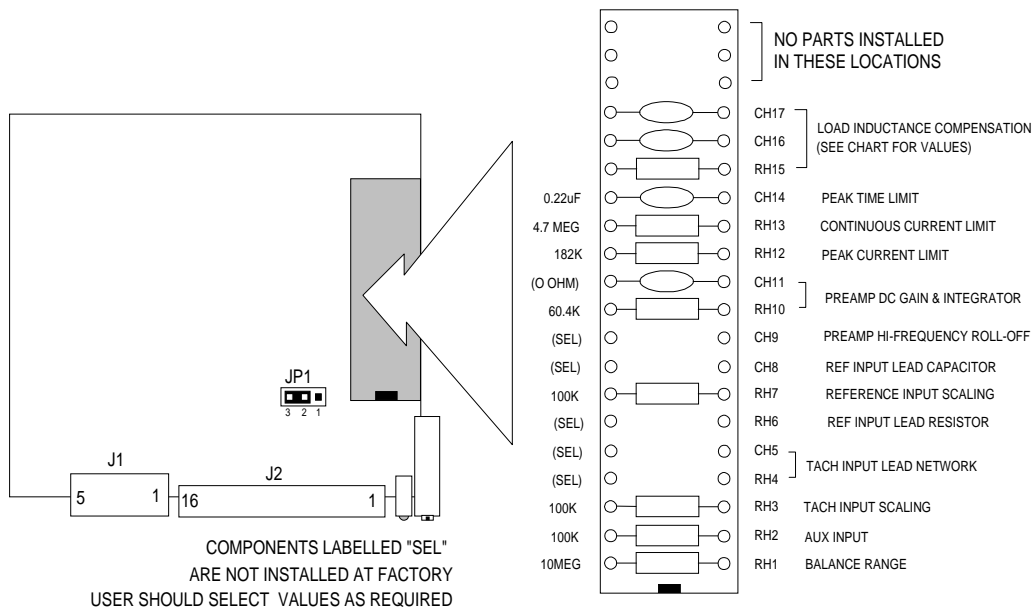

ARMATURE INDUCTANCE

Model	4122 CE			4212 CE		
Load (mH)	RH 15	CH17	CH16	RH15	CH17	CH16
0.2 to 0.5	80.6k	2.2 nF	390 pF	69.8 k	2.2 nF	390 pF
0.6 to 1.7	200k	680 pF	220 pF	100 k	1 nF	330 pF
1.8 to 4.8	402k	680 pF	180 pF	301 k	470 pF	100 pF
5 to 14	806k	680 pF	150 pF	698 k	330 pF	82 pF
15 to 45	1.5M	470 pF	100 pF	1.21M	220 pF	82 pF

Note: Values in **bold & italics** are factory installed standard. Values shown are for 90V (4122CE) and 125V (4212CE). At lower supply voltages RH15 may be increased and CH17 decreased.

PEAK CURRENT LIMIT (AMP)

4122CE	4212CE	RH12 (W)
20	12	182k
16.7	10	56k
13.3	8	30k
10	6	18k
6.7	4	9.1k
3.3	2	3.9k

CONTINUOUS CURRENT LIMIT (AMP)

4122CE	4212CE	RH13 (W)
10	6	4.7Meg
7.4	4.4	7.15Meg
5.7	3.4	10Meg

PEAK CURRENT TIME-LIMIT (SEC)

Tpeak	CH14 (uF)
1	0.47
0.8	0.33
0.5	0.22
0.3	0.15
0.2	0.10
0.1	.047

Notes on Current Limits:

1. Values in **bold & italics** are factory installed standard.
2. Peak times double after polarity reversal.
3. Peak current limit should be set greater than continuous current limit. If $I_{peak} < I_{cont}$ then peak overrides continuous limit and $I_{cont} = I_{peak}$.
Minimum setting for peak current is 0% of peak rating.
4. Continuous current sense is for average current. Symmetrical waveforms with zero average value may cause overtemperature shutdown of amplifier or motor damage due to high I^2R losses.
5. Times shown are for 100% step from 0A with default value of RH13 (4.7 Meg). When changing RH13, peak times will change. Set RH13 for continuous current limit first, then pick CH14 based on waveforms at Curr Ref (J2-9).

APPLICATION INFORMATION

**IMPORTANT! ALWAYS REMOVE POWER WHEN CHANGING
HEADER PARTS!!**

OPERATING MODES

These amplifiers operate as either open-loop current sources, or feedback devices using analog tachometers.

As open-loop current sources, the $\pm 10V$ at the reference inputs produce *current* in the load, typically a motor. The motor acts as a transducer, and converts current into *torque*, the twisting force at the motor shaft. This is called *torque mode*. It is used most frequently in systems that have controllers taking feedback from an encoder on the motor shaft. The computer calculates both position and velocity from the encoder signal, processes them in a digital filter, and outputs a signal to the motor causing it to accelerate or decelerate.

As a feedback amplifier, a signal is generated by an analog brush tachometer mounted on the motor. This is a generator that produces an analog signal that has a polarity and amplitude proportional to the motor speed. The amplifier subtracts the tach signal from the reference signal, and amplifies the *difference* between them. This is called *velocity mode*, because the amplifier changes the motor current (torque) so that the motor *velocity* is proportional to the reference signal.

TORQUE MODE OPERATION

Torque mode is the default configuration. For input voltages of $\pm 10V$, the amplifier will output its peak rated current.

In torque mode, motor current is held constant, and motor speed, or velocity changes as the load changes.

In torque mode the gain of the servo preamplifier is simply 0.6 and scales the $\pm 10V$ from the reference signal down to the $\pm 6V$ that drives the PWM stage.

The servo preamplifier integrator function is disabled, and the low gain is constant over a wide range of frequencies. Thus we sometimes call this *flat-gain* mode.

VELOCITY MODE OPERATION

The difference between the reference and tachometer signals is amplified and used to change the torque on the motor. Ideally, the difference between the command and feedback signals would be zero, so in velocity mode operation the servo preamplifier must have much higher gain than when in torque mode.

In addition, the gain must change over a range of frequencies. For "stiffness" that corrects for steady-state changes, the amplifier uses an integrator. For fast response the loop gain of the servo preamplifier must be tailored to the characteristics of the motor and tachometer. To control oscillations from the tachometer, the gain of the preamplifier must roll-off, or decrease at higher frequencies.

In velocity mode, motor speed is held constant, while motor current changes in response to changes in the load.

THE PARTS OF THE AMPLIFIER

DIFFERENTIAL AMPLIFIER

The reference signal (the command signal from the control system) is sensed by a differential amplifier. This acts like a voltmeter with two probes, measuring a voltage between two points. Current flowing in the amplifier power wiring causes voltage drops in the wires resistance. This in turn can produce a voltage at the amplifier ground that is different than the control system ground. If this voltage is added to the output of the control system, it can produce oscillation, or inconsistent operation. To eliminate this effect, you should always use *both* reference inputs.

Connect the Ref(+) input to the output of the controller card, and the Ref(-) input to ground *at the control card*. Now, the differential amplifier will measure the control signal at the control card and will reject any noise that exists between amplifier and control system grounds.

THE SERVO PREAMPLIFIER

This section processes the reference signal and any feedback signals, and generates an internal *current reference* signal that controls the PWM stage to produce output currents. It is here that the reference signal and tachometer signals are compared, and the difference signal produced and amplified.

Three components on the header control the behavior of the servo preamp. The chart below lists the default torque-mode and starting-point values for velocity mode operation:

Part	Torque	Velocity
CH9	out	220pF
RH10	60.4k	680k
CH11	short	4.7nF

CH9 controls the high-frequency roll-off.

RH10 controls the *loop gain*, and thus the step-response of the amplifier.

CH11 (along with RH7) forms the integrator that gives the stiffness at a standstill, or speed regulation while running.

CURRENT LIMITING

This stage takes the output of the servo preamplifier, and processes it before sending it to the PWM stage. The amplitude of the signal is first clamped to produce peak current limiting. This signal then goes to the continuous current-limit circuit where these functions are produced. Finally, the current-limited signal is outputted to the PWM stage as the *current-reference* signal. This signal is quite useful in that the current limit action can be seen here and measured without connecting a motor, thus protecting it from overload during initial setup.

PWM STAGE

The voltage at the output of the current limit stage is called the *current reference*. This signal becomes the *demand* signal that controls the PWM stage. Here the current demand is converted into a current in the motor. This current can be measured at the current monitor, which shows the *response* of the motor to the current demand signal. By operating as a current source, the PWM stage is able to achieve faster response from the motor than if was acting only as a variable voltage.

The *current error amplifier* compares the current reference with the current monitor, and adjusts the output voltage such that the demanded current flows in the motor. The gain of this amplifier is controlled by RH15, CH16, and CH17, which are used to *compensate* the amplifier for the motors' inductance.

INSTALLING THE AMPLIFIER

Select the header components for current limits first as this will protect the motor during later procedures. Using the Current Ref signal will allow you to view the effect of component changes on the current demand signal without loading the motor until the adjustments are complete. The effects of the current limits can best be seen by inputting a reference signal of $\pm 10V$ as a square wave of about 1/4 Hz. This way there will be enough time at peaks to observe the peak time (which will twice the unipolar time after reversals) and to see the continuous current value after the peak time occurs.

PEAK CURRENT LIMIT

Amplifiers are shipped with 182k Ω installed in RH12. This delivers the amplifiers peak rated current. For lower settings use values from the table.

CONTINUOUS CURRENT LIMIT

Choose RH13 based on the motor manufacturers specification for your motor. Table values give basic settings. This setting keeps the motor within its thermal limits. Note that this limit measures average current and will not work on symmetrical waveforms such as might occur during system oscillation. Use an external thermal circuit breaker for protection from such overcurrent faults.

PEAK-TIME LIMIT

Header component CH14 controls the length of time for which the amplifier will output peak current. When peak currents that are less than the amplifiers peak rated current, this time will increase, eventually becoming infinite as you reach the continuous current. After a polarity reversal, the peak time will be twice that of a unipolar current change.

GROUNDING & POWER SUPPLIES

Connect positive terminal of power supply to J1-5, negative terminal to J1-4. For best results do not ground power supply, but ground each amplifier with heavy wire from J1-3 to equipment 'star' ground point.

If power supply is >1m. from amplifiers, add local filter capacitor near amplifiers (250 μF minimum per amplifier).

/ENABLE INPUT

With internal jumper JP-1 on pins 2-3 (default position), the /Enable input (J2-11) must be *grounded* for the amplifier to operate. For operation with cards that output +5V to *enable* the amplifier, move the jumper on JP-1 to pins 1-2. This will reverse the /Enable input active level so that grounding the input will *inhibit* the amplifier, and +5V (or open) will enable. *Note: There is a 0.9ms delay /between Enable TRUE and amplifier ON.*

/POS & /NEG ENABLE INPUTS

These inputs are always *ground active*, open circuit or +5V will inhibit. In service these would be grounded through normally-closed limit switches. When a motion axis enters the limit, torque will be inhibited to prevent further travel into the limit, but torque will be available to back-out of the limit switch. Because torque is still available in one direction, the Normal led stays ON, and the Normal output signal remains true. *Delay on /Pos and /Neg enables is <1ms.*

TORQUE MODE SETUP

- 1) Select RH12, RH13, and CH14 for motor current-limits.
- 2) Select RH15, CH16, and CH17 on header for armature inductance.

- 3) Ground /Enable, /Pos Enable, and /Neg Enable inputs to J2-10. (Assumes default setting of JP-1 to pins 2-3)
- 4) Connect amplifier to transformer-isolated DC power supply.
- 5) Adjust value of RH10 if necessary to change transconductance.

VELOCITY MODE SETUP

Begin with the default components in positions RH10 & CH11. This will give a lower loop gain, and the integrator will be disabled. After loop gain has been adjusted as described below, the integrator is setup for best stiffness and response.

- 1) With the default components in RH10 & CH11, perform torque mode setup steps 1,2,3, and 4. This will prepare the amplifier to drive the motor within its current limits and compensate the PWM stage for motor inductance.
- 2) From the motor/tachometer datasheet, find the tachometer gradient. Typically this will be 3 or 7 *volts per krpm* (volts per thousand revolutions per minute). Multiply this number by the maximum speed (in krpm) that you want to achieve at the $\pm 10V$ reference input. For example, suppose that you have a 7 v/krpm tachometer and want to operate at 3000 rpm (3 krpm) at $\pm 10V$ input. Multiply the 7 v/krpm by 3 krpm to get 21V. Divide this number by your reference voltage (10V in this case) and get 2.1. Now multiply the value of the reference input resistor, RH7 by this number. Use the default value of 100k times 2.1 to get 210k Ω . A close production value resistor would be 220k Ω . Install this at location RH3 to *scale* the tachometer input.
- 3) Connect the motor to the Motor (+) and (-) output of the amplifier at J1-1, and J1-2. *With the motor disconnected from the load*, connect up the tachometer to the tach inputs at J2-6 & J2-7. Turn on the amplifier and spin the motor gently. If it *runs away* at high speed, turn off the amplifier and reverse the connections to the tachometer only. Power up again and the loop should now be stable and motionless (save for a small balance adjustment) at 0 reference input.
- 4) Apply a small step input voltage to the reference inputs. A 2V peak-to-peak square wave of 2Hz is a good start. Observe the signal at the tachometer input (J2-6). If the signal overshoots and undershoots for more than one cycle, then reduce the value of RH10 by 30-50% and try again. If the response is slow without any overshoot, increase RH10 by the same amount and re-try. Optimal gain will show a fast response with no overshoot, or a small amount that settles back without appreciable undershoot. If there is tachometer resonance (high pitched squealing) after this adjustment, install a 330 pF capacitor at CH9 and increase value in steps of 3X until oscillation disappears. Re-test step response.
- 5) Install a 10 nF capacitor at CH11. Test again with square wave input, or gently twist shaft with no input. Best choice of CH11 will give good stiffness at the motor shaft when tested by turning, and will show some overshoot (perhaps 10%) to a step input without ringing. As CH11 is decreased, stiffness will increase but overshoot will increase, too. If too small, CH11 will produce violent oscillation. Disable amplifier immediately and change to a larger value.

Models 4122CE, 4212CE
DC Brush Servo Amplifiers

OUTLINE DIMENSIONS

Dimensions in inches (mm.)

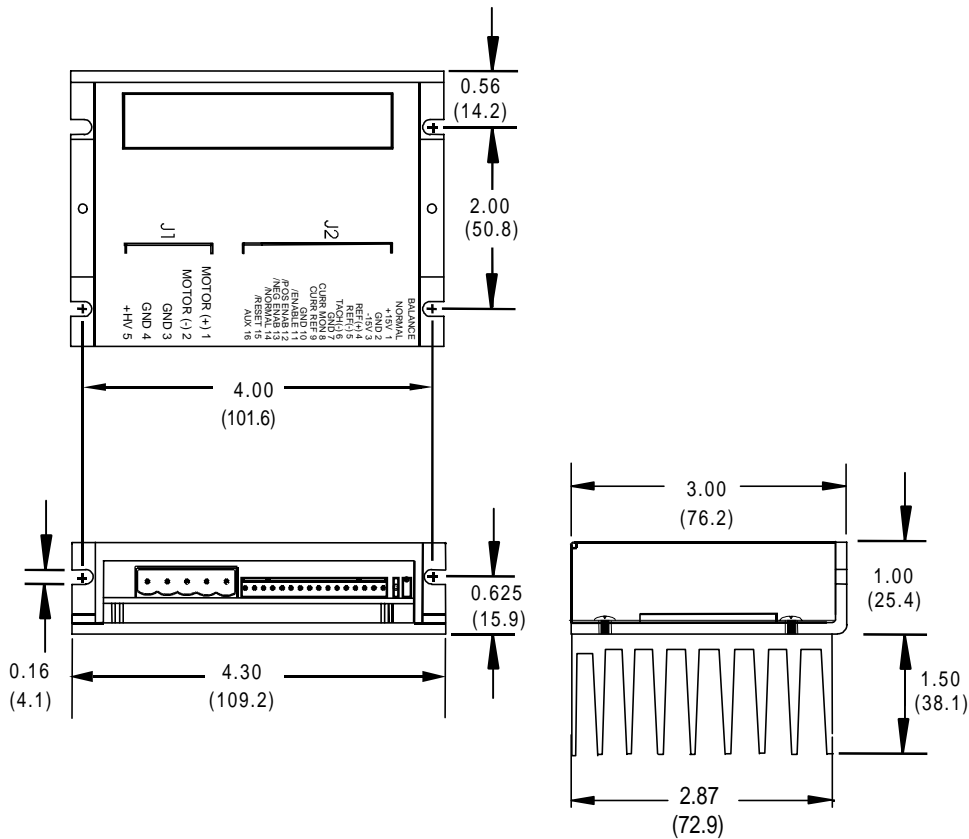

OTHER DC BRUSH SERVO AMPLIFIERS

- 400 Family** Six models operating from 24-225VDC, 5-15A continuous, 10-30A peak. Fully featured with adjustment potentiometers, voltage feedback with IR compensation.
- Model 403** For torque-mode only applications at low cost. +18 to +55VDC operation, 5A continuous, 10A peak

ORDERING GUIDE

Model 4122CE	20A peak, 10A continuous, +22 to +90VDC brush motor amplifier
Model 4212CE	12A peak, 6A continuous, +22 to 125VDC brush motor amplifier

Note: For heatsink option. Add "H" to part number. For example: 4122CEH would be a model 4122CE with heatsink.