

FEATURES

- Component socket configures amp completely
- *Flexibility!* Internal 40-pin socket configures amp with no soldering
- Separate current limits:
Continuous, peak, and peak-time
- No integrator windup when disabled
- Fault protections:
Short-circuits from output to output, output to gnd
Over/under voltage
Over temperature
Self-reset or latch-off modes
- 3kHz Current Loop Bandwidth
- Wide load inductance range: 0.2-40 mH.
- Surface mount technology construction, lower part count.

APPLICATIONS

- X-Y stages
- Robotics
- Automated assembly machinery
- Magnetic bearings

THE OEM ADVANTAGE

- Conservative design for high MTBF
- No soldering required to change header parts.
- Custom configurations available (contact factory)
No-pots, custom headers

MODEL	POWER	I-CONT	I-PEAK
4122D	+22 to +90 VDC	10	20
4212D	+22 to +125 VDC	6	12



DESCRIPTION

Models 4122D and 4212D are third-generation amplifiers for dc brush motors from Copley Controls Corp. Built using surface-mount technology, these amplifiers offer plug and play operation in a very small package. Both models take digital, one or two wire PWM signals as command inputs, and convert them to internal $\pm 10V$ to operate motors in torque or velocity mode.

Two-wire PWM data format interfaces with microcontrollers such as the National LM-629, or control cards that output a 0% to 100% PWM signal for magnitude, and a DC signal for direction. Positive or negative logic levels are jumper-selectable.

One wire format uses a 50% duty cycle PWM command for '0' and 0% or 100% duty cycles for positive and negative full-scale.

A differential analog input takes brush tachometer signals for velocity-loop operation.

Model 4122D operates from +22 to +90VDC unregulated power supplies, and outputs 10A continuous, 20A peak.

Model 4212D operates from +22 to +125VDC power supplies, and outputs 6A continuous, and 12A peak.

The active logic-level of the amplifier Enable input is jumper selectable to GND or +5V to interface with different control cards.

The /Pos and /Neg enable inputs remain ground active for fail-safe operation.

A mosfet H-bridge output stage delivers power in four-quadrants for bi-directional acceleration and deceleration of motors.

An internal solderless socket holds 17 components that configure the various gain and current limit settings to customize the amplifiers for a wide range of loads and applications.

Header components permit compensation over a wide range of load inductances to maximize bandwidth with different motors.

Individual peak and continuous current limits allow high acceleration without sacrificing protection against continuous overloads. Peak current time limit is settable to match amplifier to motor thermal or commutation limits.

All models are protected against output short circuits (output to output and output to ground) and heatplate overtemperature.

With the /Reset input open, output shorts or heatplate overtemperature will latch off the amplifier until power is cycled off & on, or until the /Reset input is grounded. For self-reset from such conditions, wire /Reset to ground and the amplifier will reset every 200ms.

A bicolor led speeds diagnostics during set-up, or for fault isolation after the unit is in service.

Models 4122D, 4212D

DC Brush Servo Amplifiers with PWM Inputs

FUNCTIONAL DIAGRAM

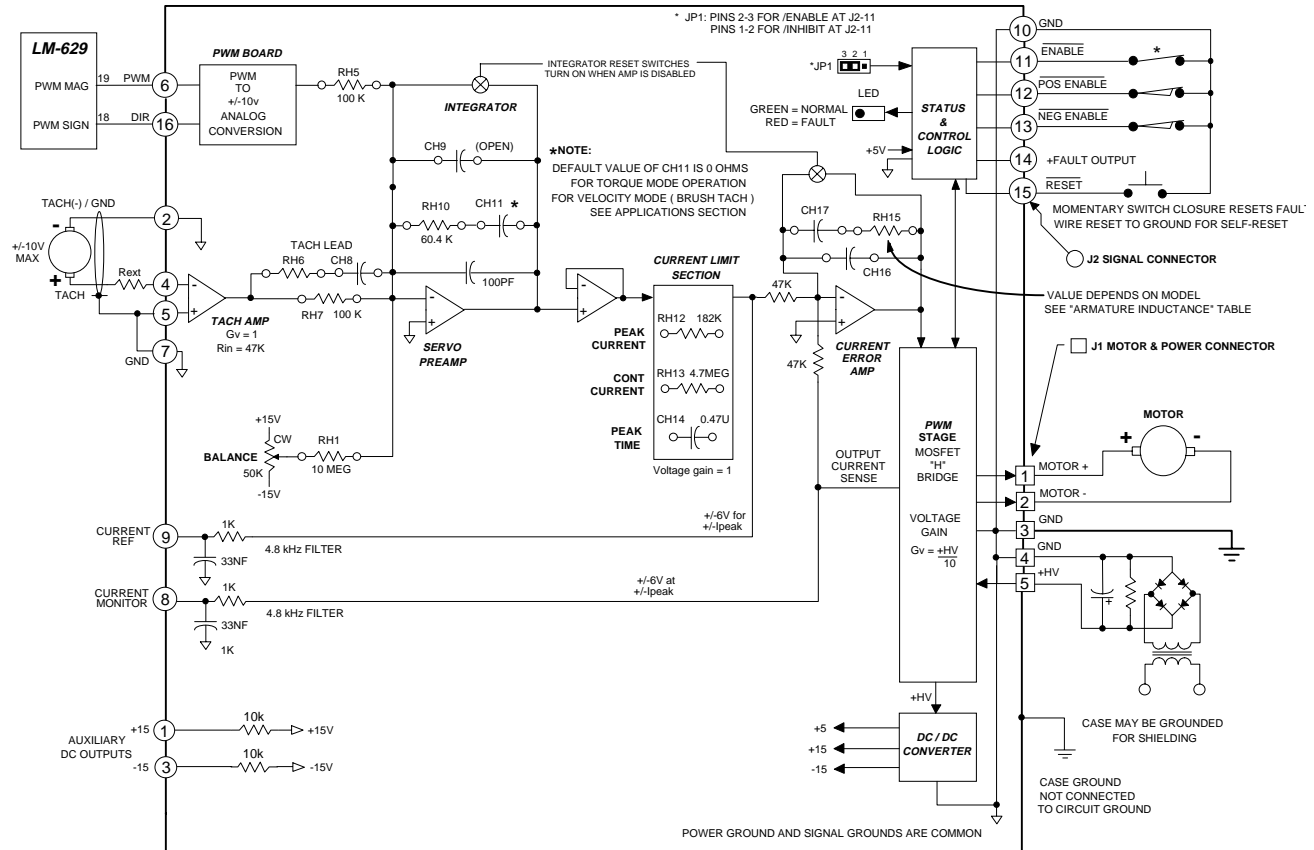

typical connections

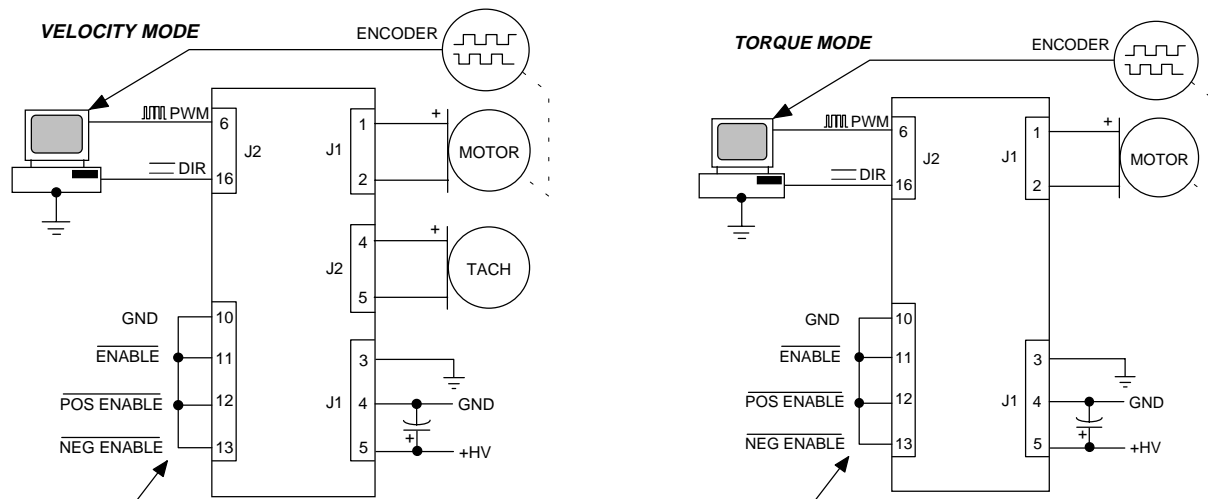

Note: JP1 on pins 2-3 (default)

Note: JP1 on pins 2-3 (default)

Notes

1. All amplifier grounds are common (J1-3, J1-4, J2-2, J2-7, and J2-10) Amplifier grounds are isolated from case & heatplate..
2. Jumper JP1 default position is on pins 2-3 for ground active /Enable input (J2-11)
For /Inhibit function at J2-11 (+5V enables), move JP1 to pins 1-2
3. For best noise immunity, use twisted shielded pair cable for tachometer inputs.
Twist motor and power cables and shield to reduce radiated electrical noise from pwm outputs.

Models 4122D, 4212D

DC Brush Servo Amplifiers with PWM Inputs

TECHNICAL SPECIFICATIONS

Test conditions: 25°C ambient, Load = 200μH. in series with 1 Ω., +HV = maximum normal value

MODEL	4122D	4212D
OUTPUT POWER		
Peak power	±20A @ ±80V	±12A @ ±120V
Peak time	1 sec unipolar from 0A, 2 secs. after polarity reversal	
Continuous power	±10A @ ±80V	±6A @ ±120V
OUTPUT VOLTAGE		
$\pm V_{out} = \pm HV * (0.97) - (R_o) * (I_o)$		
Ro = 0.2		Ro = 0.1
LOAD INDUCTANCE		
Selectable with components on header socket: 200 μH to 40mH		
BANDWIDTH		
Reference PWM inputs	1.5kHz	
Output PWM stage:	3kHz with 200μH load at maximum supply voltage, varies with load inductance and RH15, CH16 & CH17 values	
PWM OUTPUT BRIDGE SWITCHING FREQUENCY		
25kHz		
REFERENCE LOGIC INPUTS		
Digital, pulse-width modulated (PWM). One or two-wire format, positive or negative logic. Logic threshold 2.5VDC. Input voltage range 0 to +12V.		
GAINS		
Input PWM to analog conversion	100% duty cycle produces ±10V to preamplifier stage.	
PWM transconductance stage	I _{peak} / 6V (1 peak = peak rated output current; 6V measured at Current Ref J2-9)	
CONTROL LOGIC INPUTS		
Input voltage range	0 to +24V	
Logic threshold voltage (LO to HI transition)	2.5V (Schmitt trigger inputs with hysteresis)	
/Enable (Internal jumper JP1 reverses logic)	LO enables amplifier, HI disables (Default function with JP-1 on pins 2-3. For +5V enable and GND inhibit, move JP1 to pins 1-2)	
Time delay on Enable	0.9 ms after Enable true to amplifier ON, <1ms to disable	
/POS enable, /NEG enable	Gnd enables positive or negative output currents. +5V or open inhibits (<1ms delay) (Setting of JP-1 has no effect on ground-active level of /POS and /NEG enable inputs)	
/Reset	LO resets latching fault condition, ground for self-reset every 200 ms.	
Input resistance	10K pull-up to +5V, R-C filters to internal logic	
POTENTIOMETER		
Balance	Use to set output current or rpm to zero. RH1 = 10 MΩ for Balance function, RH1 = 100kΩ for Test function	
LOGIC OUTPUT		
+Fault (/Normal)	HI = Overtemp OR output short OR power NOT-OK, OR NOT-Enabled; LO = Operating normally AND enabled	
HI output voltage	+5V (3.3kΩ pullup resistor to +5V) +50V maximum	
LO output voltage	<0.5V typical, 1.25V @ 250mA max, Ro = 5Ω (mosfet on resistance)	
INDICATOR (LED)		
Normal	Green: ON = Amplifier Enabled AND Normal (power OK, no output shorts, no overtemp) Red = Fault (NOT Normal, amplifier NOT enabled, or fault condition)	
ANALOG MONITOR OUTPUTS		
Current Ref (current demand signal to pwm stage)	±6V @ demands ±I _{peak}	
Current Monitor (motor or load current)	±6V @ ±I _{peak} (1kΩ, 33nF R-C filter)	
DC POWER OUTPUTS		
±15VDC each output in series with 10kΩ		
PROTECTIVE FEATURES (Note 1)		
Output short circuit (output to output, output to ground)	Latches unit OFF	
Overtemperature	Latches unit OFF at 70°C on heatplate	
Undervoltage shutdown @	<20V	<20V
Overvoltage shutdown @	>92VDC	>129VDC
POWER REQUIREMENTS		
DC power (+HV) Transformer isolated from power mains	+22 to +90VDC	+22 to +125VDC
Watts minimum	2.5W	2.7W
Watts @ Icont	25W	41W
THERMAL REQUIREMENTS		
Storage temperature range: -30 to +85°C; operating temperature range: 0 to 70°C baseplate temperature		
Notes: 1. Heatsink optional (add "H" to model number) 2. Fan = forced air over unit @ 400 linear feet/minute		
MECHANICAL		
Amplifier case size	4.3 x 3.0 x 1.18 in. (109 x 76.2 x 30 mm.)	
Heatsink	Adds 1.50 in. (38.1 mm) to amplifier 1.0 in. dimension. Same length as amp.	
Weight	0.43 lb (0.2 kg.) for amplifier alone; heatsink adds 0.78 lb. (0.35 kg)	
CONNECTORS		
J1 (Power & motor): 5 position compression-connector; Phoenix MKDS 3; maximum wire gauge AWG 12 (4 mm ² solid or 2.5 mm ² stranded) wire.		
J2 (Signal): 16-position 0.1" centers housing (Molex: 22-01-3167) with AWG 30-22 crimp contacts (Molex 08-50-0114 , 16 required)		
NOTES		
1. Latching faults disable amplifier until power is cycled off-on, or /Reset input is grounded. Non-latching faults re-enable amplifier when fault condition is removed. Overtemperature and short-circuits are latching faults, under or overvoltage faults are non-latching. If /Reset input is grounded, amplifier will auto-reset from latching faults every 200ms.		

Models 4122D, 4212D

DC Brush Servo Amplifiers with PWM Inputs

CONNECTORS AND PINOUTS

J1: MOTOR & POWER CONNECTIONS

Pin	Signal	Remarks
1	Motor (+)	Amplifier output to motor (+) winding
2	Motor (-)	Amplifier output to motor (-) winding
3	GND	Power supply return. Connect to system ground at this pin.
4	GND	Power supply return. Connect to system ground at this pin.
5	+HV	+HV DC power supply input

J2: AMPLIFIER BOARD CONNECTIONS

Pin	Signal	Remarks
1	+15V	+15V in series with 10k Ω
2	Gnd	Signal ground
3	-15V	-15V in series with 10k Ω
4	Tach (+)	Tachometer feedback input. $\pm 20V$ maximum between J2-4 and J2-5 without external scaling.
5	Tach (-)	Tachometer feedback input. $\pm 20V$ maximum between J2-4 and J2-5 without external scaling.
6	PWM input	Digital reference input. 0% to 100% duty cycle controls output current magnitude. (Note 1)
7	Gnd	Signal ground
8	Curr Mon	Output current monitor: $\pm 6V$ output at \pm peak output current
9	Curr Ref	Current demand signal to output PWM stage: $\pm 6V$ demands \pm peak current
10	Gnd	Signal ground
11	/Enable	Amplifier enable input: enables or inhibits PWM switching at outputs Default: Gnd enables amplifier, open or +5V inhibits (JP1 @ 2-3) For controllers that output +5V to enable amplifier, move internal jumper JP1 to pins 1-2 (Gnd will inhibit, +5V or open will enable)
12	/Pos Enab	Gnd to enable output current in one polarity, open or +5V to inhibit Typically used with grounded, normally closed limit switches.
13	/Neg Enab	Gnd to enable output current in opposite polarity, open or +5V to inhibit. Typically used with grounded, normally closed limit switches.
14	/Normal	Current-sinking when amplifier enabled and operating normally.
15	/Reset	Goes to +5V when amplifier disabled or fault condition exists. Ground to reset overtemp or output short circuit latching faults. For automatic reset of faults every 200mS, ground permanently.
16	DIR input	Output current polarity (direction) input. Polarity switches from positive to negative with DC level of input. (Note 1)

BALANCE POTENTIOMETER

Default position: centered. Functions to bring output current (in torque mode) or output velocity (in tachometer mode) to zero with control system outputs at zero. Normal range is $\pm 1\%$ of full scale with 10Meg resistor in header location RH1. To use the pot as a wide range set-point adjustment, install a 150k Ω resistor at RH1. Now, full CW or CCW will have the effect of a 100% duty-cycle signal at the PWM inputs.

STATUS LED

Color	+HV	/Enable	Short	Overtemp
Green	Normal	Active	None	Normal
Red	Too low or too high	X	X	X
	X	Inhibited	X	X
	X	X	Output short	X
	X	X	X	Too hot
Note	1, 5	2, 5	3, 5	4, 5

Notes:

- Input function changes with input type. See Applications section for details.
- +HV normal >20V and <92V for model 4122D, >20V and <129V for model 4212D
- /Enable is ground-active for JP1 on pins 2-3 (default). To reverse function, switch JP1 to pins 1-2.
- Shorts detected by overcurrent circuit are between outputs, or from outputs to ground.
- Overtemperature faults occur when heatplate temperature is >70 $^{\circ}$ C
- +HV and /Enable cause momentary amplifier shutdown, operation is restored when +HV is within normal limits and /Enable input is active. Output shorts, and overtemperature faults *latch-off* amplifier. Thus amplifier will remain off until power is cycled on/off, or /Reset input is grounded momentarily. If /Reset input is wired to ground, output short and overtemperature faults will self-reset every 200ms.

COMPONENT HEADER

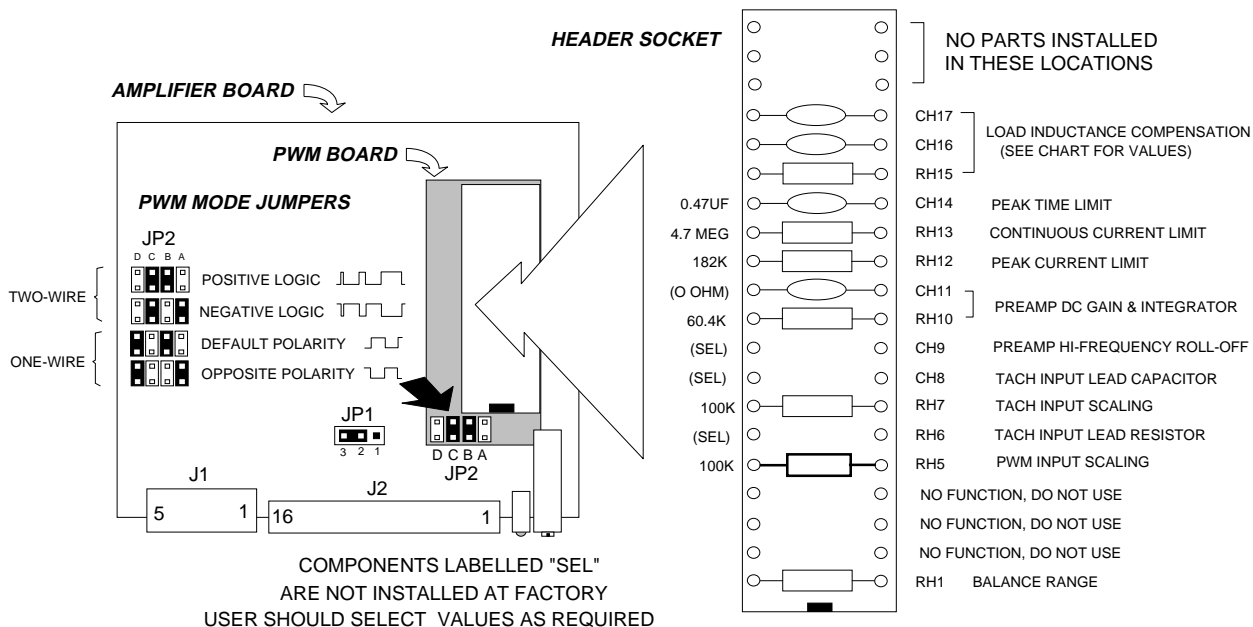

ARMATURE INDUCTANCE

Model	4122D			4212D		
Load (mH)	RH 15	CH17	CH16	RH15	CH17	CH16
0.2 to 0.5	80.6k	2.2 nF	390 pF	69.8 k	2.2 nF	390 pF
0.6 to 1.7	200k	680 pF	220 pF	100 k	1 nF	330 pF
1.8 to 4.8	402k	680 pF	180 pF	301 k	470 pF	100 pF
5 to 14	806k	680 pF	150 pF	698 k	330 pF	82 pF
15 to 45	1.5M	470 pF	100 pF	1.21M	220 pF	82 pF

Note: Values in **bold & italics** are factory installed standard. Values shown are for 90V (4122D) and 125V (4212D). At lower supply voltages RH15 may be increased and CH17 decreased.

PEAK CURRENT LIMIT (AMP)

4122D	4212D	RH12 (Ω)
20	12	182k
16.7	10	56k
13.3	8	30k
10	6	18k
6.7	4	9.1k
3.3	2	3.9k

CONTINUOUS CURRENT LIMIT (AMP)

4122D	4212D	RH13 (Ω)
10	6	4.7Meg
7.4	4.4	7.15Meg
5.7	3.4	10Meg

Notes on Current Limits:

- Values in **bold & italics** are factory installed standard.
- Peak times double after polarity reversal.
- Peak current limit should be set greater than continuous current limit.
If $I_{peak} < I_{cont}$ then peak overrides continuous limit and $I_{cont} = I_{peak}$.
Minimum setting for peak current is 0% of peak rating.
- Continuous current sense is for average current. Symmetrical waveforms with zero average value may cause overtemperature shutdown of amplifier or motor damage due to high I^2R losses.
- Times shown are for 100% step from 0A with default value of RH13 (4.7 Meg). When changing RH13, peak times will change. Set RH13 for continuous current limit first, then pick CH14 based on waveforms at Curr Ref (J2-9).

PEAK CURRENT TIME-LIMIT (SEC)

Tpeak	CH14 (μF)
1	0.47
0.8	0.33
0.5	0.22
0.3	0.15
0.2	0.10
0.1	.047

APPLICATION INFORMATION

IMPORTANT! ALWAYS REMOVE POWER WHEN CHANGING HEADER PARTS!!

PWM REFERENCE INPUTS

PWM (pulse-width modulated) inputs are digital signals that carry the information for magnitude and sign of the output current, or the motor velocity. Magnitude information tells the amplifier to output from zero to 100% of its rated current. Sign information defines the polarity (positive or negative) of the output current, or the direction of the motor rotation.

Two-wire PWM data

Also called 100% modulation, this type used two lines. The PWM input has a duty cycle that ranges from 0% to 100% and controls the magnitude of the output current (or the percent of maximum velocity). The DIR input controls the sign of the output current (or the direction of motor rotation).

Positive or negative logic can be used. In positive logic, the zero level is OFF, and the one-level controls magnitude. In negative logic, +5V is the zero-level, with ground transitions controlling magnitude.

To reverse the function of the DIR input, simply reverse the connections between the motor to the Mot(+) and Mot(-) terminals. If a tachometer is used, reverse both motor and tachometer wires.

one-wire PWM data

Also called 50% modulation, this format uses only one line which connects to the DIR input. The PWM input is left open. The PWM signal has a duty cycle of 50% that represents zero output from the amplifier. A 0% duty cycle then represents full output in one polarity, and a 100% duty cycle represents full output in the opposite polarity. To reverse the function of the DIR input, simply reverse the connections between the motor to the Mot(+) and Mot(-) terminals. If a tachometer is used, reverse both motor and tachometer wires.

PWM mode jumpers

There are four jumpers at location JP2 on the PWM card. The chart below shows their positions and functions as they relate to the different input types. The two-wire positive logic connection is the default.

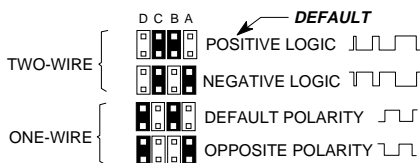

These amplifiers operate as either open-loop current sources, or feedback devices using analog tachometers. Current in a motor winding produces torque, and a tachometer voltage shows motor velocity. From this we get *torque mode*, and *velocity mode*.

Torque mode

As open-loop current sources, the PWM signals at the reference inputs produce *current* in the load, typically a motor. It

is used most frequently in systems that have controllers taking feedback from an encoder on the motor shaft. The computer calculates both position and velocity from the encoder signal, processes them in a digital filter, and outputs a signal to the motor causing it to accelerate or decelerate.

velocity mode

As a feedback amplifier, a signal is generated by an analog brush tachometer mounted on the motor. This is a generator that produces an analog signal that has a polarity and amplitude proportional to the motor speed. The servo preamplifier subtracts the tach signal from the reference signal, and amplifies the *difference* between them, changing the motor current (torque) so that the motor *velocity* is proportional to the reference signal.

THE PARTS OF THE AMPLIFIER

PWM INPUT CIRCUIT

The PWM card has circuits that convert the digital PWM reference signal(s) into an internal $\pm 10V$ reference signal that drives the servo preamplifier. Header component RH5 controls the scale factor and has a default value of 100k Ω . With two-wire inputs, a 100% duty cycle signal is converted to a $\pm 10V$ analog signal with the polarity following the DC level at the DIR input. With the default values in the header, this is then scaled to $\pm 6V$ after the current limit stage, which then drives the output PWM stage to its peak rated current.

THE SERVO PREAMPLIFIER

This section processes the reference signal and any feedback signals, and generates an internal *current reference* signal that controls the PWM stage to produce output currents. In torque mode the stage simply scales the $\pm 10V$ internal reference input to $\pm 6V$ for the output PWM stage. And, it is here that the reference signal and tachometer signals are compared, and the difference signal produced and amplified.

Three components on the header control the behavior of the servo preamp. The chart below lists the default torque-mode and starting-point values for velocity mode operation:

Part	Torque	Velocity
CH9	out	220pF
RH10	60.4k	680k
CH11	short	4.7nF

CH9 controls the high-frequency roll-off.

RH10 controls the *loop gain*, and thus the step-response of the amplifier.

CH11 (along with RH7) forms the integrator that gives the stiffness at a standstill, or speed regulation while running.

CURRENT LIMITING

This stage takes the output of the servo preamplifier, and processes it before sending it to the PWM stage. The amplitude of the signal is first clamped to produce peak current limiting. This signal then goes to the continuous current-limit circuit where these functions are produced. Finally, the current-limited signal is outputted to the PWM stage as the *current-reference* signal. This signal is quite useful in that the current limit action can be seen here and measured without connecting a motor, thus protecting it from overload during initial setup.

OUTPUT PWM STAGE

The voltage at the output of the current limit stage is called the *current reference*. This signal becomes the *demand* signal that controls the PWM stage. Here the current demand is converted into a current in the motor. This current can be measured at the current monitor, which shows the *response* of the motor to the current demand signal. By operating as a current source, the PWM stage is able to achieve faster response from the motor than if it was acting only as a variable voltage.

The *current error amplifier* compares the current reference with the current monitor, and adjusts the output voltage such that the demanded current flows in the motor. The gain of this amplifier is controlled by RH15, CH16, and CH17, which are used to *compensate* the amplifier for the motors' inductance.

INSTALLING THE AMPLIFIER

Select the header components for current limits first as this will protect the motor during later procedures. Using the Current Ref signal will allow you to view the effect of component changes on the current demand signal without loading the motor until the adjustments are complete. The effects of the current limits can best be seen by moving the PWM jumper from B to A and inputting a TTL (0 / +5V) level square wave of about 1/4 Hz at the DIR input with the PWM input open-circuit. This way there will be enough time at peaks to observe the peak time (which will twice the unipolar time after reversals) and to see the continuous current value after the peak time occurs.

PEAK CURRENT LIMIT

Amplifiers are shipped with 182k Ω installed in RH12. This delivers the amplifiers peak rated current. For lower settings use values from the table.

CONTINUOUS CURRENT LIMIT

Choose RH13 based on the motor manufacturers specification for your motor. Table values give basic settings. This setting keeps the motor within its thermal limits. Note that this limit measures *average* current and will not work on symmetrical waveforms such as might occur during system oscillation. Use an external thermal circuit breaker for protection from such overcurrent faults.

PEAK-TIME LIMIT

Header component CH14 controls the length of time for which the amplifier will output peak current. When peak currents that are less than the amplifiers peak rated current, this time will increase, eventually becoming infinite as you reach the continuous current. After a polarity reversal, the peak time will be twice that of a unipolar current change.

GROUNDING & POWER SUPPLIES

Connect positive terminal of power supply to J1-5, negative terminal to J1-4. For best results do not ground power supply, but ground each amplifier with heavy wire from J1-3 to equipment 'star' ground point.

If power supply is >1m. from amplifiers, add local filter capacitor near amplifiers (250 μ F minimum per amplifier).

/ENABLE INPUT

With internal jumper JP-1 on pins 2-3 (default position), the /Enable input (J2-11) must be *grounded* for the amplifier to operate. For operation with cards that output +5V to *enable* the amplifier, move the jumper on JP-1 to pins 1-2. This will reverse the /Enable input active level so that grounding the input will *inhibit* the amplifier, and +5V (or open) will enable. *Note: There is a 0.9ms delay /between Enable TRUE and amplifier ON.*

/POS & /NEG ENABLE INPUTS

These inputs are always *ground active*, open circuit or +5V will inhibit. In service these would be grounded through normally-closed limit switches. When a motion axis enters the limit, torque will be inhibited to prevent further travel into the limit, but torque will be available to back-out of the limit switch. Because torque is still available in one direction, the Normal led stays ON, and the Normal output signal remains true. *Delay on /Pos and /Neg enables is <1ms.*

TORQUE MODE SETUP

- 1) Select RH12, RH13, and CH14 for motor current-limits.
- 2) Select RH15, CH16, and CH17 for armature inductance.
- 3) Ground the /Enable, /Pos Enable, and /Neg Enable inputs to J2-10. (Assumes default setting of JP-1 to pins 2-3)
- 4) Connect amplifier to transformer-isolated DC power supply.
- 5) Adjust value of RH10 if necessary to change transconductance.

VELOCITY MODE SETUP

There are three basic steps to follow to set up the amplifier in velocity mode.

- 1) Tach Scaling: Select Rext, the external scaling resistor so that motor reaches desired top speed at 100% input duty cycles.
- 2) Loop Gain Adjust: Select RH10 and CH9 for best response to step inputs.
- 3) Integrator Frequency: Select CH11 for best steady-state speed regulation and stiffness at a standstill.

These adjustments are most easily made with a square-wave input of alternating polarity. A simple way of producing this condition is to replace RH1 with a 1 Meg resistor, and rotate the balance pot fully CW. With the PWM jumpers in the default positions connect a +5V logic square wave to the DIR input (J2-16) at a frequency of about 1/2 Hz. Connect an oscilloscope to the tach signal at J2-4. If the motor 'runs-away' when you power-up, reverse the tachometer connections for stable operation.

1) Tach scaling: You must know the tachometer *gradient*, usually given in volts / krpm (volts per thousand rpm). Multiply this value, typically 3 or 7 v/krpm, by your top speed in krpm. If the result is greater than 10V, then you must add an external scaling resistor in series with one of the tachometer wires (see functional diagram). Find the value using this formula:

$$R_{ext} = (\text{MaxTachVolts} \times 5k\Omega) - 50k\Omega$$

VELOCITY MODE SETUP (cont'd)

If your maximum voltage was 35V (7v/krpm X 5 krpm), then Rext would be 125kΩ, or the next smaller value..

2) Loop Gain Adjust: Observe the leading edge of the tach signal. If it rises slowly and doesn't overshoot, you can increase loop gain by increasing the value of RH10. Begin by doubling it and re-test. Select the final value such that the tach signal rises as fast as possible with the minimum overshoot (<5%). To minimize noise in the step response, add capacitance at CH9 until it affects the step response. Use the largest value that does not degrade the step response.

3) Integrator Frequency Adjust (Stiffness): Remove the shorting jumper at CH11 and replace with a 10nF capacitor. If the motor oscillates violently, change this to a 33nF and repeat the test. With the motor stable, observe the step response. When the integrator functions well, you will observe some overshooting at each edge of the square wave and the motor will be 'stiff' at a standstill. The overshoot can be between 10-20%, and should settle cleanly to the steady-state value. Remove the square wave from the DIR input and twist the motor shaft gently. With optimal adjustment it will oppose your twisting effort and will not 'hunt' when you release it. Smaller values of CH11 will increase overshoot to a step input and stiffness at a standstill. Select CH11 for the best stiffness and response to a square wave input.

When you have finished these adjustments, replace the resistor at RH1 with the 10 Meg default value and adjust the motor speed to zero with no reference inputs.

OUTLINE DIMENSIONS

Dimensions in inches (mm.)

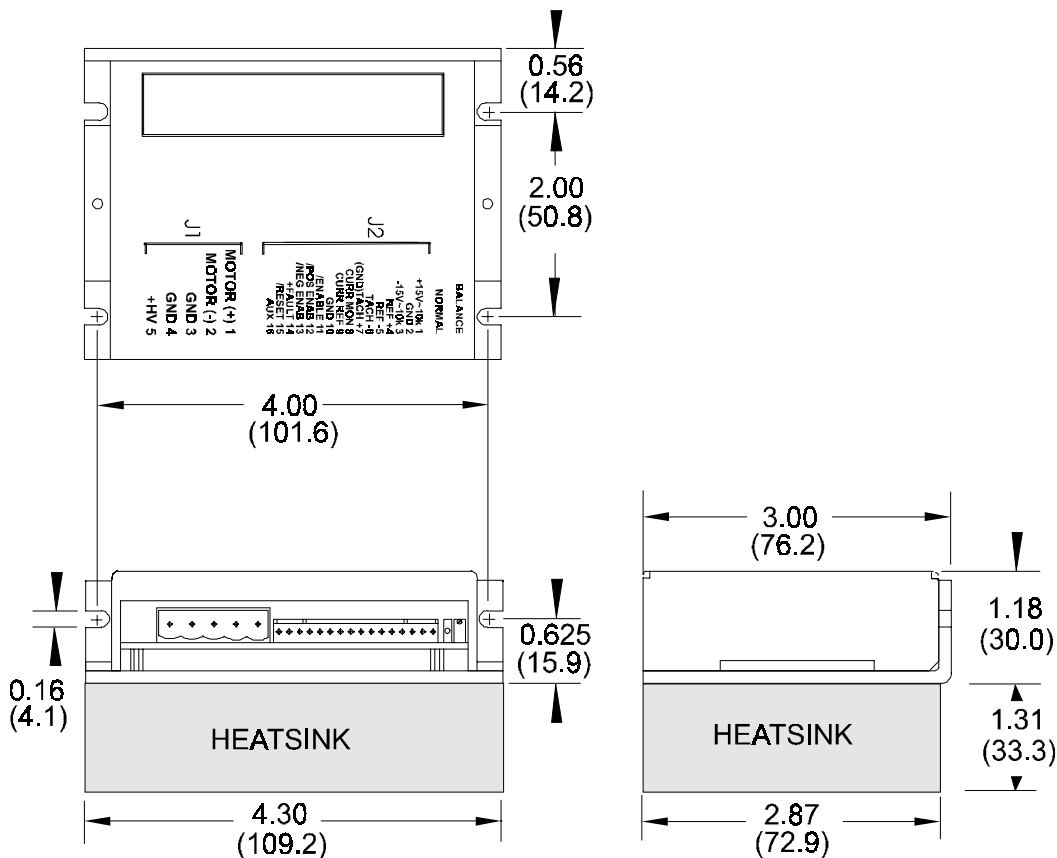

OTHER DC BRUSH SERVO AMPLIFIERS

- 400 Family** Six models operating from +24 to +225VDC, 5-15A continuous, 10-30A peak. Fully featured with adjustment potentiometers, voltage feedback with IR compensation.
- Model 403** For torque-mode only applications at low cost. +18 to +55VDC operation, 5A continuous, 10A peak
- Model 405** Same power output ratings as model 403, but provides tachometer function from digital encoders by frequency to voltage conversion.

ORDERING GUIDE

Model 4122D	20A peak, 10A continuous, +22 to +90VDC brush motor amplifier with PWM inputs
Model 4212D	12A peak, 6A continuous, +22 to +125VDC brush motor amplifier with PWM inputs

Options:

1. Add "PMF" to part number for "pins" version of amplifier with output edge filters on accessory mounting card.
2. Add "D" to part number for logic-level PWM inputs instead of $\pm 10V$ analog inputs
3. Add "H" to part number for heatsink option.
4. Option digit sequence: amplifier with all options would be 4122DPMFDH or 4212DPMFDH.